



DELUXE STITCHER

COMPANY INC.

Head Serial Number : _____

Date Purchased : _____

Where Installed: _____
(make/model of machine)

26/26D Stitcher Head

OPERATION AND MAINTENANCE MANUAL

Wire Sizes: 21-28 Ga. Round and 21x25 Flat
Crown Sizes: 5/16" (8 mm), 3/8" (9.5 mm),
1/2" (12.7mm) and 5/8" (15.9mm)
Capacity: 2 sheets to 1/4" (6.4 mm)

Before using this Stitcher Head, all operators must study this manual and follow the safety warnings and instructions. Keep these instructions with the 26/26D Stitcher Head for future reference. If you have any questions, contact your local DeLuxe Stitcher Graphic Arts Representative or Distributor.

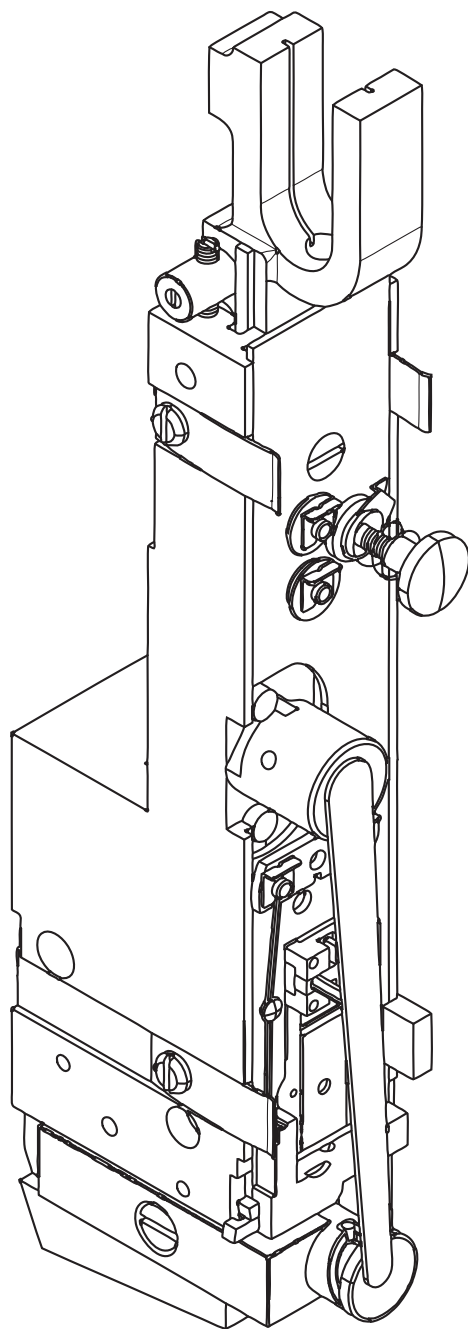

*Thank you for choosing the
26/26D STITCHER HEAD
for your binding needs*

WARNING!

26/26D Stitcher Head

Machine operators and others in the work area should always wear safety glasses to prevent serious eye injury from fasteners and flying debris when loading, operating, or unloading this machine.

Do not operate this stitcher head without all stitcher machine guards in place. Do not modify the guards in any way. Always disconnect the power supply before removing any guards for servicing.

Never operate the machine with wire feeding through the head unless there is stock above the clinchers, otherwise serious damage may result.

Always turn power off when making adjustments. Always disconnect the power cord before any disassembly work.

Table of Contents

Introduction	4
Part Number Definition.....	5
Specifications.....	6
Installation	8
Pre-Inspection	8
Inspection	8
Mounting	10
Operation	12
Wire Threading	12
Wire Straightening	13
Adjustments and Settings	14
Maintenance.....	18
Lubrication	18
Cleaning	19
How to Order Spare Parts.....	20
Replacing Spare Parts.....	20
Troubleshooting.....	25
Formed Staple Chart	25
Appendices	27
Exploded Drawings.....	27
Part Number/Description Cross Reference	37
Variable Crown and Wire Sizes.....	40
Registration Card.....	43
Wear/Replacement Parts.....	44
Warranty	45

Introduction

The DeLuxe Stitcher Company 2001DHD Series, 2301DHD Series, 2601AHD Series, 2601DHD and 2601 EHD Series Wire Stitcher Heads are basically identical with respect to operation. Variations occur in some of the component parts due to adapting that basic head to single stitch and gang stitch machines and also due to model design changes. Variations between the 2601AHD Series and the 20001DHD Series can be recognized by a comparison of the Swivel Holders.

These heads were designed over 75 years ago, yet they still remain the most popular stitcher head sold in the world. The 26/26D heads are reliable, durable and economically priced.

Typical Style Uses:

2001DHD	No. 2 and No. 10 Wire Stitchers
2301DHD	No. 23 Wire Stitchers
2601EHD	No. 16E and 17E Wire Stitchers
2601DHD/2601AHD	Automatic Saddle-Stitchers,
.....	Gang-Stitchers, Multibinders and Others

Examples of Replacement Heads for OEM Users*:

AM Graphics / Sheridan	
455, 562, 690	2601DSHD251/2
AM Graphics / Sheridan 705	2601DOHD251/2
Bourg	2601DOHD251/2
Christensen	2601DSHD251/2
Macey Multibinder	2601AOHD251/2 and 2601DSHD251/2
McCain	2601DCMC251/2
Pitney Bowes	2601APBHD251/2 and 2601APB2HD251/2
Rosback	2601AOHD251/2
Watkiss	2601AWAHD251/2

* These are just a few examples of the replacement heads available for these OEM's.

Part Number Definition

The part number for each Stitcher Head can be used to define the stitcher head itself, in most cases. The Head's model type, mounting style, nominal wire size and crown size can all be determined from the part number.

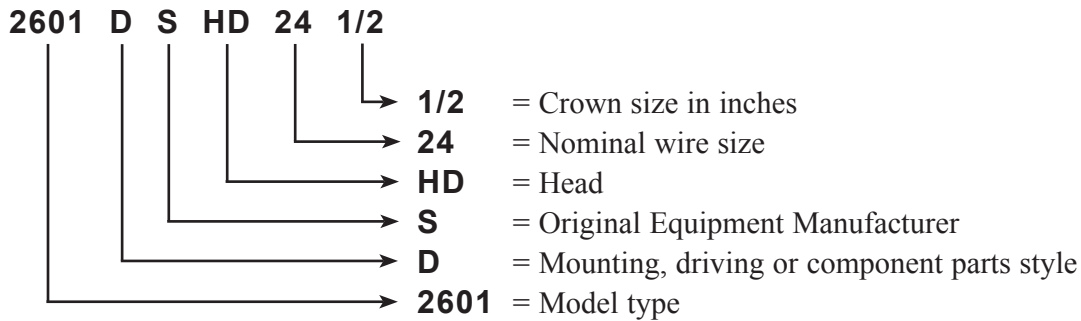

Model Differences

Generally speaking, the following part numbers indicate which Stitcher Heads can be used as replacement heads for your Stitcher Machine or collating system*.

- 2001 - 2-AW Stitcher
- 2301 - Model 23 Stitcher
- 2601 - 17-AW and most other saddle equipment manufacturers
- AHD - The "A" style head with a shorter Operating Spring and one-piece Swivel Holder
- AOHD, APBHD, DCMCHD, DSHD, ARHD, AWAHD - Specially designed heads for specific manufacturers such as Pitney Bowes, McCain, Sheridan, Rosback and Watkiss.
- ASMHD - Heads for DeLuxe Stitcher Company StitchMaster and MiniStitcher machines
- BHD - Head which mounts to the stitcher machine with a "bolt," typically on single-head machine
- DHD - The "D" style head with three-piece Swivel Holder, and more durable Operating Spring, Hub and Driving Slide
- EHD - Head typically used on Bostitch 17AW's or No. 17's
- MHD - Head specially designed for multi-head M-Series Stitchers

* **These are just examples and should be used as reference only.**

Specifications

Weight

Shipping Weight 7 lbs (3.2 kg)

Physical Dimensions

Height 10-3/4" (26.3 cm)

Width 2" (5.1 cm)

Stitching Capacity Two Sheets to 1/4" (6.4 mm)

Wire Types 21 through 28 round or 21 x 25 flat
(25 gauge round standard)

Crown Sizes 5/16" (8mm)
..... 3/8" (9.5mm)
..... 1/2" (12.7mm)
..... 5/8" (15.9mm)

Minimum Head Centers

..... 1-7/8" (47.6mm)

Stitches Per Hour 12,000

Replacement for: Interlake/Acme/Champion heads

Dimensions

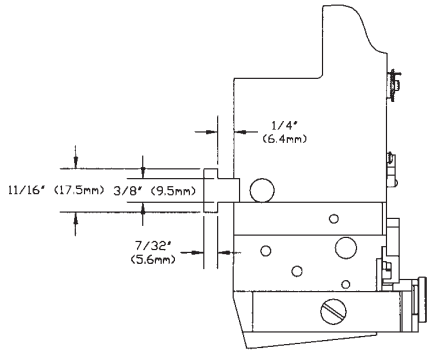

*T-SLOT FOR ADJUSTABLE AND GAND MOUNTING OF HEADS

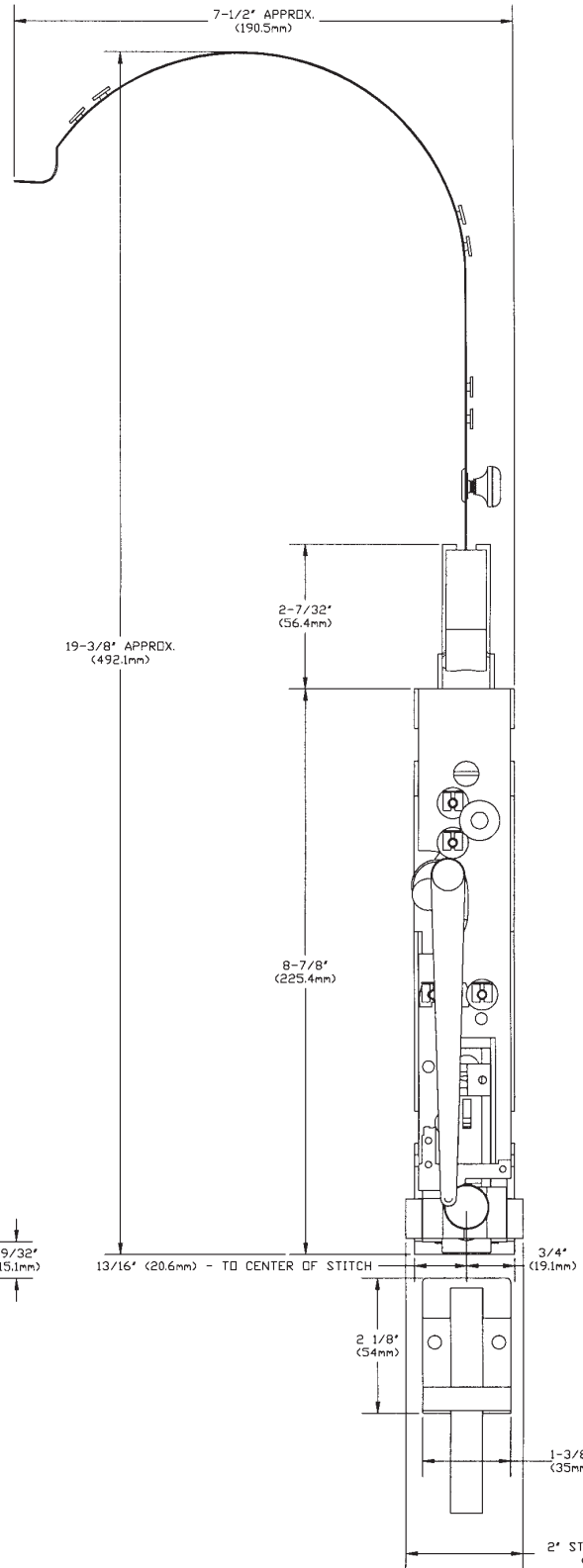
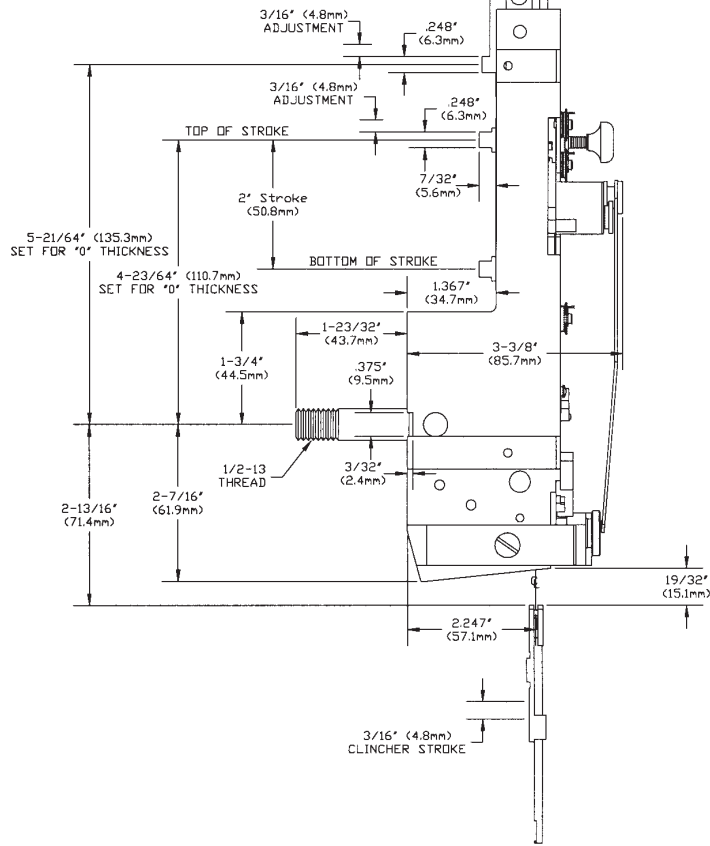

Installation

Pre-Inspection

Carefully inspect the condition of the shipping container before unpacking your 26/26D Stitcher Head. If the container is broken or damaged and there is evidence that the stitcher head may be damaged, immediately notify the carrier who delivered the head and the DeLuxe Stitcher Graphic Arts Representative from whom the 26/26D Stitcher Head was purchased.

Inspection

As you carefully unpack the head, check to make sure all components were delivered and are in good working order. Refer to **Figure 1** in this manual for reference to the following pieces:

- 26/26D Manual
- Driver Release Pin
- Wire Guide Spring Assembly
- Bonnet Clamp Block and Bonnet Clamp Handle on 2601AHD, 2601DHD and 2601EHD style heads
- Bonnet Binder Stud, Bonnet Stud Pin and Bonnet Stud Nut on 2001DHD and 2301DHD style heads
- Clincher Plate, Points and Slide (supplied with most heads)
- Driving Shaft Connector Link on 2001DHD and 2301DHD style heads
- Stitch Samples

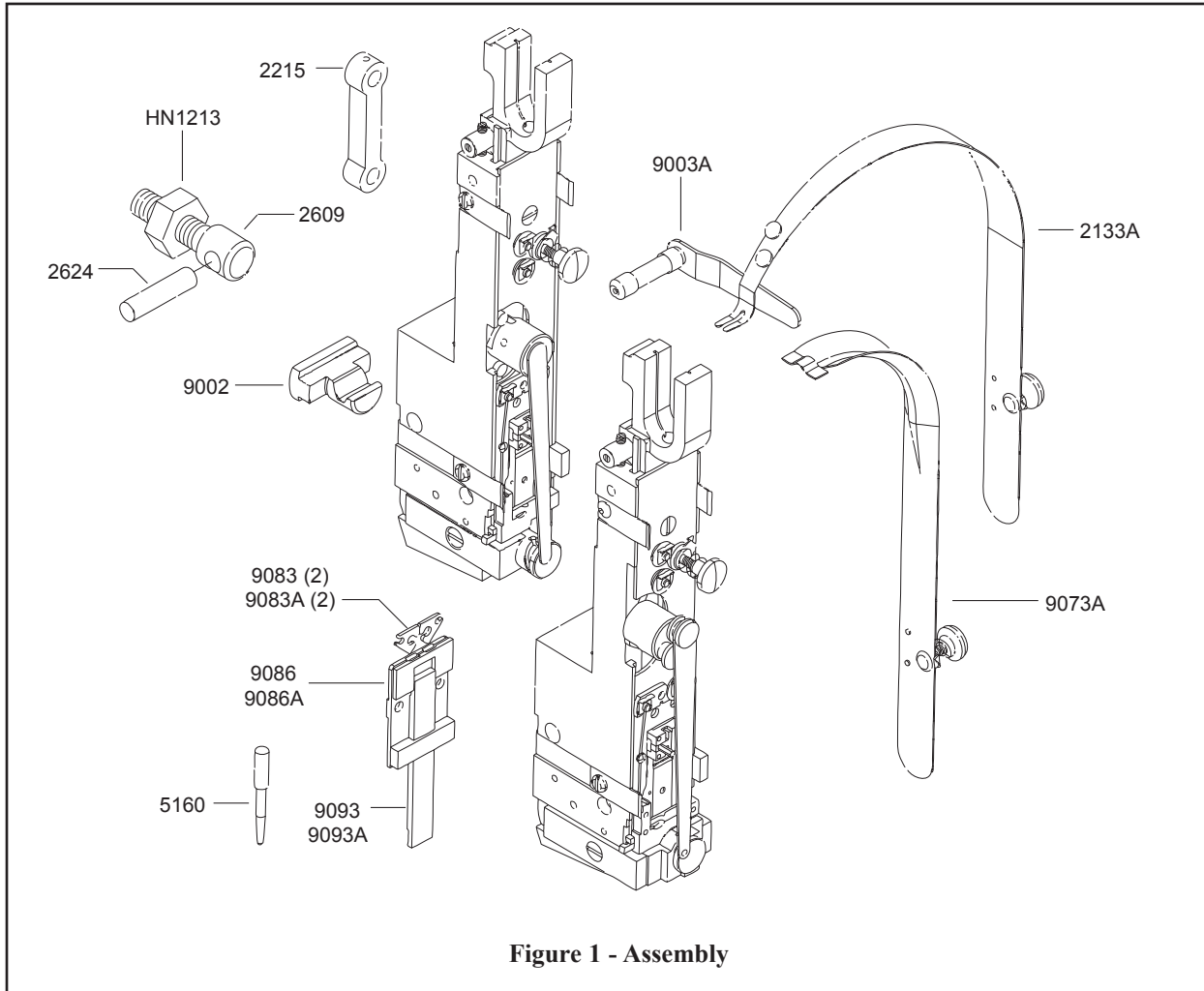

Pre-Installation

Please take a few moments to fill out the registration card located on page 43 prior to beginning installation.

Always disconnect the power supply before making any adjustments or servicing the head.

⚠ WARNING

Mounting

The quality and quantity of work that can be produced by the DeLuxe Stitcher Company Heads is dependent upon the operator making the various operating adjustments as accurately as possible. The following illustrated instructions are provided so that the operator will clearly understand how to make the various required operating adjustments.

2601AHD, 2601DHD and 2601EHD (Slot Mount/Rail Drive)

To remove the 2601AHD Series, the 2601DHD Series and the 2601EHD Series Heads, raise the clamping Eccentric Handle (9003A) until the Bonnet Clamp Block (9002) disengages (approximately an 11 o'clock position). The head can then be removed from the stitcher. Refer to **Figure 2**.

When attaching the 2601AHD Series, the 2601DHD Series and the 2601EHD Series Heads to the stitching machine, check to see that the Driving Slide Lug (2602) and the Face Plate Adjustment Slide (2610) are engaged in the grooves of the stitching machine's Driving and Adjusting Rails. Lock the Bonnet (2601R) in position by pressing down on the clamping Eccentric Handle.

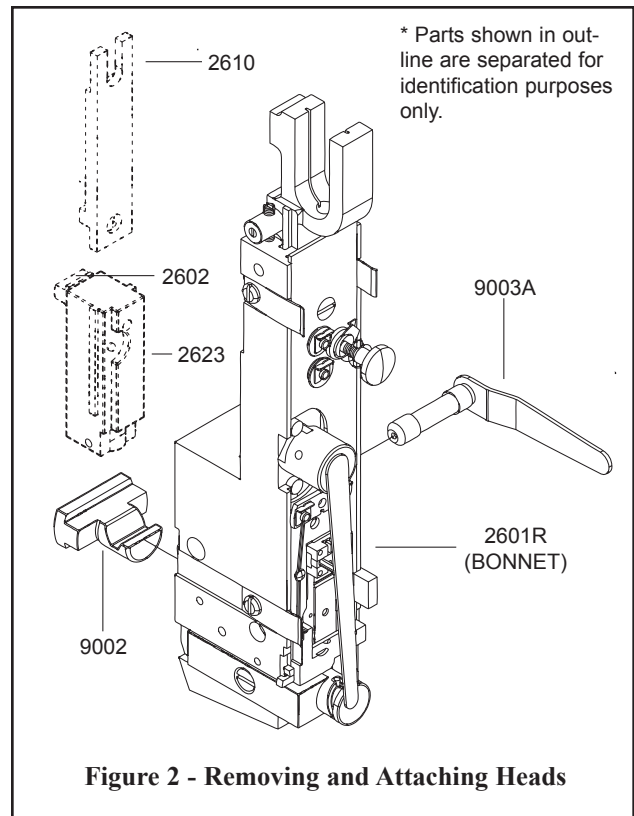

Figure 2 - Removing and Attaching Heads

2001DHD and 2301DHD (Bolt Mount/Crank Drive)

To remove the 2001DHD or the 2301DHD Series stitcher heads from No. 2 and No. 23 style Stitching Machines, rotate the Drive Pulley on the stitcher machine until the Grip (9015) on the 2001DHD or 2301DHD style head closes on the wire. Remove the Bonnet Binder Stud Nut (HN1213) and withdraw the head from the machine. **Refer to Figure 3.**

NOTE: Instructions may vary with other types of Bolt Mount/Crank Drive machines.

To attach the head, rotate the Drive Pulley on No. 2 and No. 23 style Stitcher Machines manually until the stitcher's Driving Crank is at the top of its stroke. Engage the Driving Shaft Connecting Link

(2215) with the Driving Slide Pin. (2103B) on the back of the stitcher head. The Driving Slide Pin must be inserted in the lower hole of the Link. (The lower hole of the Link is the one opposite of the oil hole.) With the Link held in a vertical position, line the head up with the machine. Engage the machine's Crank Pin in the upper hole of the Driving Shaft Connecting Link and insert the Binder Stud Pin (2624) in the mounting hole of the Bonnet casting.

Push the the 2001DHD Series Head into position until the Bonnet Binder Stud (2609), which is secured to the Stitcher Head with the Bonnet Stud Pin

(2624), is fully inserted into the machine's mounting hole and the stitcher's Face Plate Adjusting Link Eccentric is positioned within the hole in the Head's Face Plate. (2132BA or 2146CA) If the Link Eccentric is not in alignment with the hole in the Face Plate, adjust the machine's Compression Knob or Handle or the Face Plate until it is.

Verify that the Driver Shaft Connecting Link (2215) is squarely engaged with the Crank Pin on the stitcher machine and the Driving Slide Pin (2103B) on the stitcher head and that they do not bind. Secure this position with the Bonnet Stud Nut. (HN1213)

After the head is securely attached to the machine, turn the machine over manually or activate it in jog mode, to check that the head operates freely. Until it operates freely, do not run the head under power.

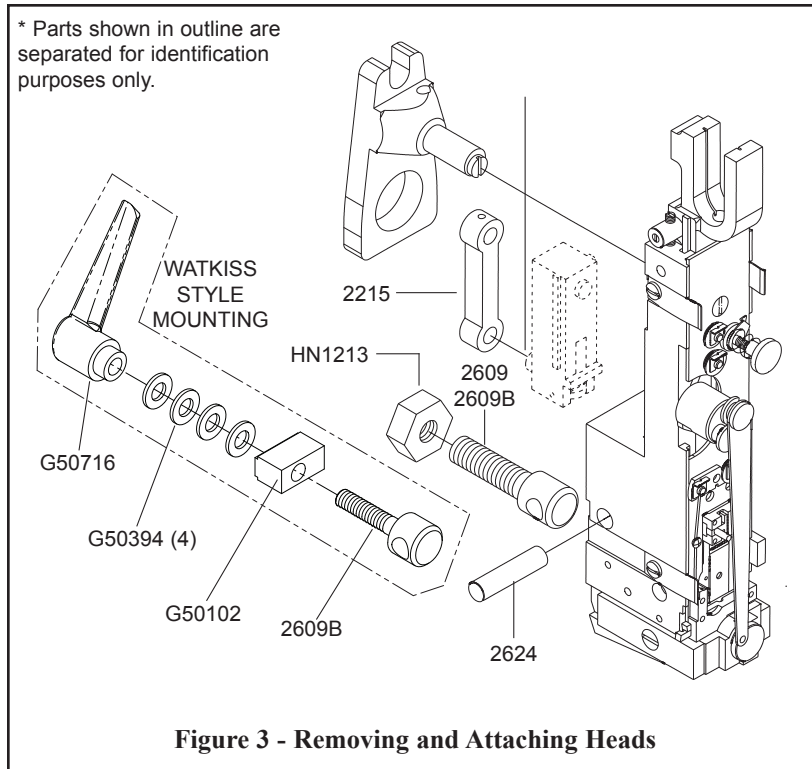

Always disconnect the power supply before making any adjustments or servicing the head

WARNING

Operation

Wire Threading (Figures 4 & 5)

1. Disengage the Swivel Operating Spring (2155A) and remove the Swivel (9038A or 9038M) from the stitcher head.

2. Pass the wire from the Spool over the Wire Guide Spring Assembly (2133A), between the Guide Spring Studs (2110B) and under the flanges of the Wire Straightener Rollers (9103) on the Spring as well as between the Wire Straightener Eccentric Roller (9065) and the Wire Straightener Rollers on the Face Plate (2146CA).

3. Continue to pull the wire through the Tension Pawl (9098) and through the hole in the Face Plate, located at the top of the Wire Cutter (9048) Holder and through the Swivel Holder (9043B or 2147). At this point, do not worry if the wire is not fed between the Grip (9015) and the Grip Holder area.

NOTE: The Tension Pawl will hold the wire in the Wire Straightener Roller's (9103) groove. This will allow the wire to feed through the Head but not allow it to "back-up."

4. Pull enough wire through the bottom of the Head to clear away what was bent in the threading process.

5. With the Swivel still removed, power the stitcher machine on and complete one cycle under power to allow the wire to automatically thread between the Grip and the Grip Holder. This will also cut off any excess wire below the Cutters.

NOTE: Hold the Swivel operating Spring away from the Swivel Holder so as not to damage it.

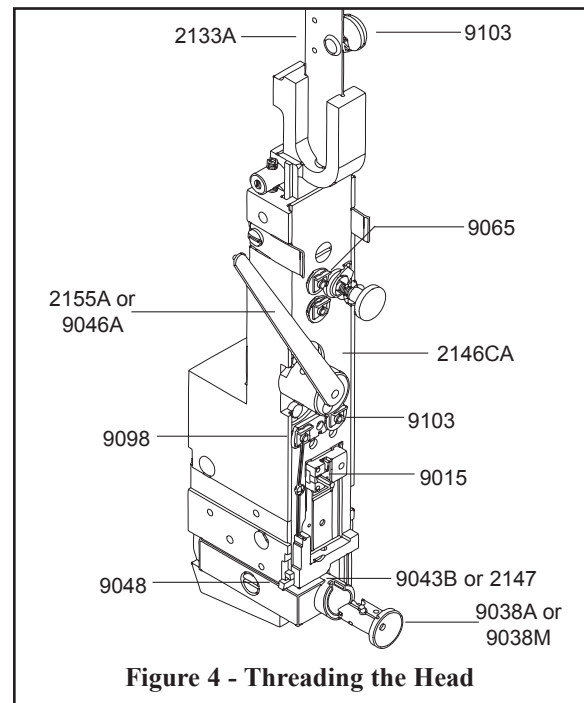

Figure 4 - Threading the Head

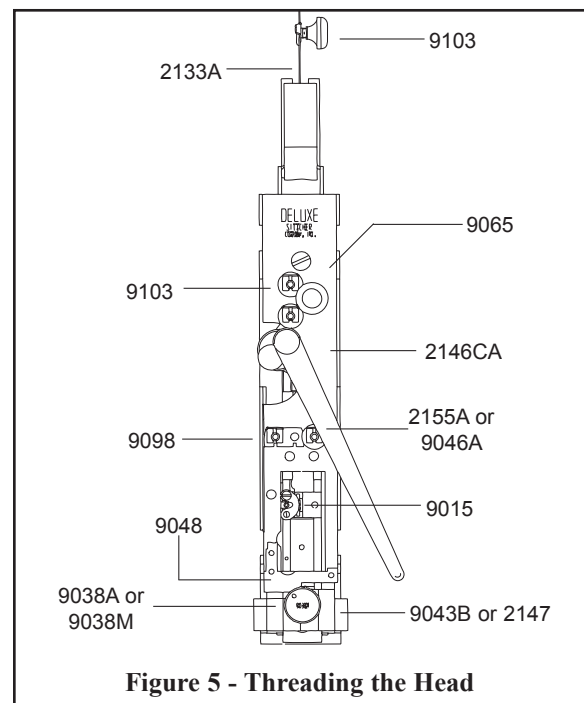

Figure 5 - Threading the Head

Wire Straightening (Figure 6)

In order to ensure the stitches are loaded, driven and clinched properly in addition to ensuring continuous operation of the 26 style heads, it is important that the wire enters the Swivel (9038A or 9038M) in straight vertical line. Wire straightness is the single biggest factor for ensuring good stitches and stitcher head reliability. Although straightness is set at the factory, every roll of wire has varying degrees of twist which make it necessary for the user to properly straighten the wire prior to production **as well as during normal production**. Follow the steps for straightening wire listed below.

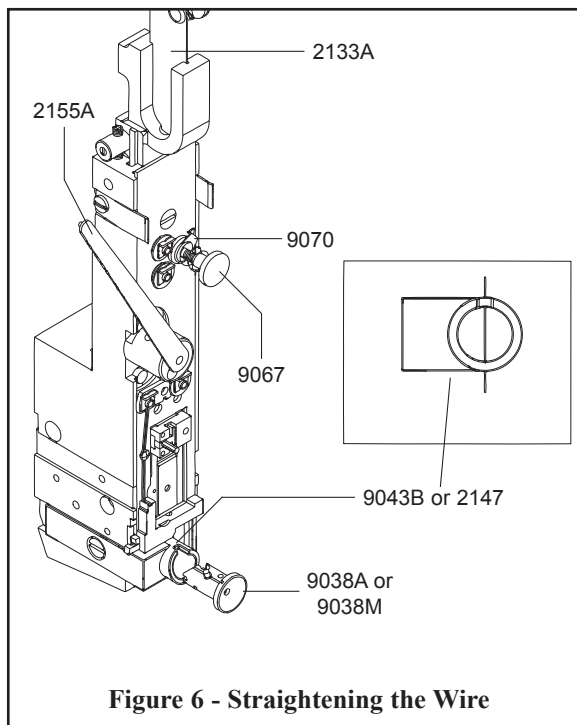

Figure 6 - Straightening the Wire

Right-to-Left Adjustment

Disengage the Swivel Operating Spring (2155A) from the Swivel (9038A or 9038M) and remove the Swivel. Rotate the Operating Spring to a 10 o'clock position and remove it as well. **On A Style heads, remove the Swivel Operating Hub (9163) as well.** Activate the stitcher and observe the feeding of the wire through the Swivel Holder (9043B or 2147) and take note of the direction the wire is moving. Use the Wire Straightener Eccentric Nut (9067) on the Face Plate (2146CA) to adjust the wire. If the wire is feeding to the left, turn the Wire Straightener Eccentric Nut counter-clockwise. If the wire is feeding to the right, turn the Eccentric Nut clockwise. Allow enough wire to be fed through the Head so that an accurate assessment can be made. After an adjustment is made it take approximately four to six stitches to take effect.

The Pointer, (9070) attached to the Wire Straightener Eccentric Nut, and the graduated markings on the Face Plate provide a reference point for straightening the wire. The numbers have no real value though and will vary from head to head and with each spool of wire.

Front-to-Back Adjustment

If the wire is feeding in a straight line (left to right), but tends to curl forward or backward, turn the Wire Straightener Adjustment Nut (9067) on the Wire Guide Spring Assembly (2133A) clockwise or counter-clockwise as required, until the condition is remedied. After the adjustments have been made so that the wire is feeding in a straight line, replace the Swivel and re-engage the Swivel Operating Spring.

Adjusting the Length of the Left Leg (Figure 7)

Once the 26/26D style Stitcher Head has been threaded and the wire straightness has been obtained, it is time to begin stitching. Activate the stitcher machine to load one piece of wire in the Swivel (9038A or 9038M). Even though the 26/26D Stitcher Heads have been tested at the factory, the wire draw adjusted and the legs equalized, the following are directions to make these adjustments if necessary.

If the staple is off-center, meaning one leg is longer than the other, the length of the left leg has to be changed. Loosen, do not remove, the Wire Guide Spring Bracket Screw (9075) and the Wire Guide Adjustment Binder Screw. (1060) Using a screwdriver, turn the Wire Guide Spring Bracket Screw (56) clockwise if a shorter left leg is necessary and counter-clockwise if a longer left leg is necessary. A slight turn of the Adjusting Screw will usually prove sufficient to achieve the desired length. A quarter turn of the Adjusting Screw will make a considerable difference in the length of the staple's leg. Once the desired length has been achieved, tighten the Binder Screw and the Wire Guide Spring Bracket Screw. At this point, the left leg should be approximately one half the width of the crown.

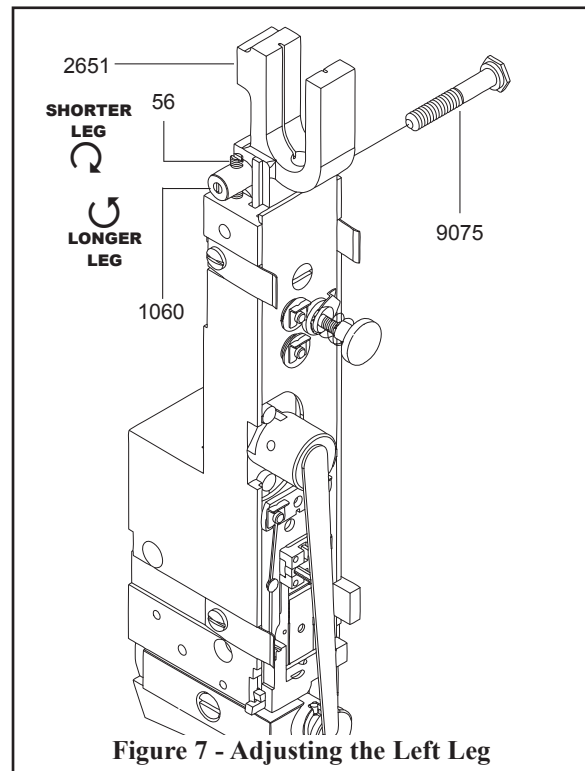

Figure 7 - Adjusting the Left Leg

NOTE: If the staple leg has been lengthened, meaning the Wire Guide Spring Bracket Screw has been turned counter-clockwise, tap down on the Wire Guide Spring Bracket (2651) before tightening the Wire Guide Spring Bracket Screw.

Adjusting the Wire Draw

The overall length of the stitch is controlled by the amount of wire that is drawn from the spool after each stroke of the stitcher machine. To change the overall length of the stitch, the stitcher head's Face Plate has to be raised or lowered accordingly.

2001DHD Series Head (Figure 8)

Loosen the Eccentric Binder Screw found on the stitcher machine behind the right side of the Stitcher Head. Turn the Adjusting Link Eccentric clockwise, which is found in the center of the Face Plate (2146CA). The clockwise turn of the Eccentric will raise the Face Plate, draw more wire from the Spool and make the overall length of the stitch longer. If the overall length of the wire is too long, turn the Adjusting Link Eccentric counter-clockwise to lower the Face Plate and decrease the draw of the wire pulled from the Wire Spool. After the adjustment has been made, tighten the Eccentric Binder Screw on the stitcher machine that was previously loosened. As a rough gauge, the distance the Face Plate is above the Bonnet (2601B) should be equal to the work thickness. This adjustment will have to be made every time the compression setting on the Stitcher Machine is changed.

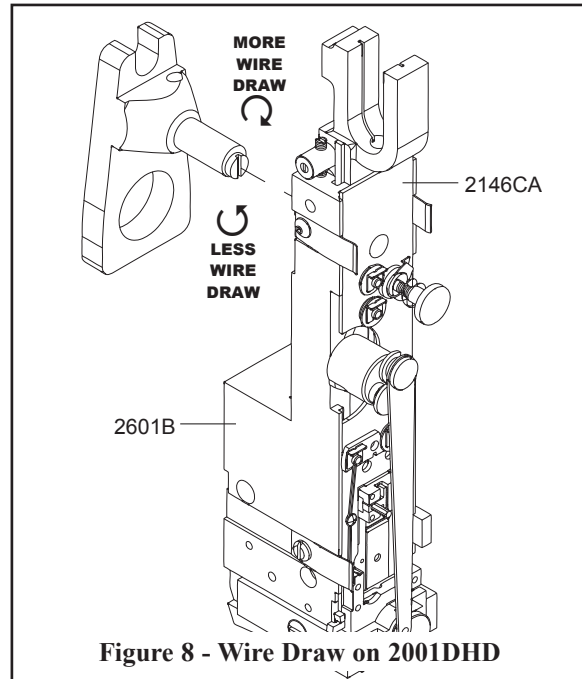

2301DHD Series Head and other Heads without Face Plate Adjusting Slides (Figure 9)

Loosen the Face Plate Locating Screw (2608) found in the center of the Face Plate (2146CA). To increase the overall length of the stitch, raise the Face Plate slightly by applying pressure at the bottom edge of the Face Plate. Use a large screwdriver as a lever under the Wire Cutter (9048) Holder area of the Face Plate. Raising the Face Plate draws more wire from the Wire Spool and increases the length of each staple leg. To shorten the staple legs or draw less wire from the Wire Spool, lower the Face Plate slightly by tapping the top edge of the Face Plate. After the adjustments have been made, tighten the Face Plate Locating Screw. As a rough gauge, the distance the Face Plate is above the Bonnet (2601B) should be equal to the work thickness. This adjustment will have to be made every time the compression setting on the Stitcher Machine is changed.

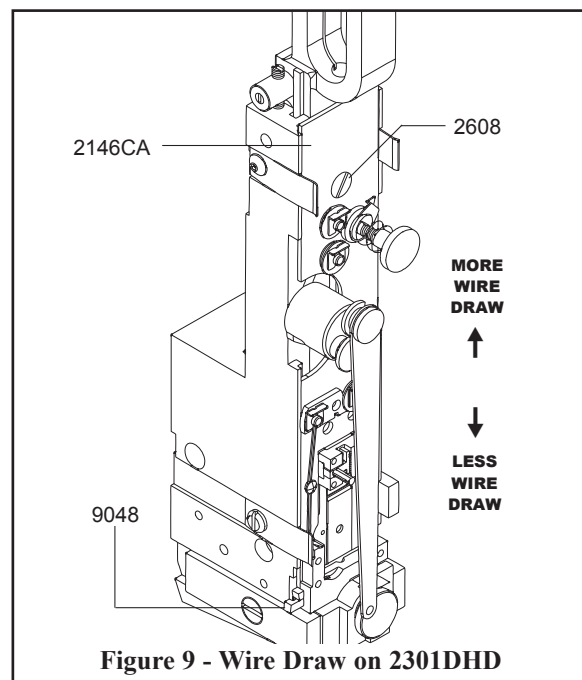

2601AHD, 2601DHD and 2601EHD Series Heads (Figure 10)

Loosen the Face Plate Adjusting Slide Nut (2613) found in the center of the Face Plate (2146CA). To increase the overall length of the stitch, raise the Face Plate slightly by applying pressure at the bottom edge of the Face Plate. Use a large screwdriver as a lever under the Wire Cutter (9048) Holder area of the Face Plate. Raising the Face Plate draws more wire from the Wire Spool and increases the length of each staple leg. To shorten the staple legs or draw less wire from the Wire Spool, lower the Face Plate slightly by tapping the top edge of the Face Plate. After the adjustments have been made, tighten the Face Plate Locating Screw. As a rough gauge, the distance the Face Plate is above the Bonnet (2601B) should be equal to the work thickness. As a rule, this adjustment should only have to be made once since this style Head automatically adjusts itself when the compression setting of the Stitcher machine is changed. Some minor modifications may have to be made for individual jobs though.

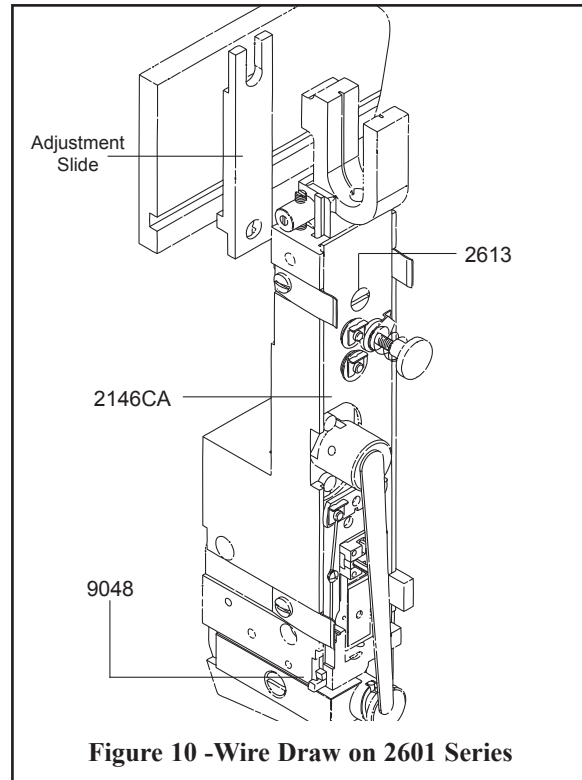

Make sure all guards are in place before operating the stitcher head

! WARNING

Adjusting the Clincher Points

2001DHD and 2601AHD, 2601DHD and 2601EHD Series Heads (Figure 11)

The final position of the Clincher Points* (round or flat, thick or thin) should be flush, or slightly above flush, with the Clincher Plate* (round or flat, thick or thin) in order to achieve a quality stitch. The best way to see the position of the Clincher Points is to manually turn the stitcher machine over. When the Driver* (depending on the wire gauge being used) is at the lowest position of its stroke, the Clincher Points are at their highest position. Turn the stitcher machine just past this point to reveal the Clincher Points' position. Clincher Points that do not pivot high enough will produce a weak clinch, where Clincher Points that pivot too high will cause poor stitch quality or cut the stock being stitched.

* For a complete list of wear parts and replacement parts based on wire gauge and crown size, see page 46 of this manual.

If the clinch on the staple is not tight enough, the Clincher Points (9083A) have to be raised, assuming the Stitcher machine's compression setting is correct. If the legs of the staple are being pushed back through the stock, the Clincher Points are set too high and have to be lowered. These adjustments are specific to each stitcher machine and cannot be fully explained in this manual, since many Machines have Clincher Lever adjustments built in. Consult the stitcher machine's operating manual for complete Clincher Point adjustment instruction. This is especially useful when using non-adjustable Clincher Plates. If the machine is using an Adjustable Clincher Plate, like the one shown in **Figure 11**, adjust the Clincher Points as follows. Loosen the Set Screw (UA4808.7) on the top of the Clincher Slide (9084B). Turn the Clincher Slide Adjustment Screw (9087) clockwise to lower the Clincher Points and turn the Clincher Slide Adjustment Screw counter-clockwise to raise the Clincher Points. Once the Clincher Point height is set, tighten the Set Screw on the front of the Clincher Slide.

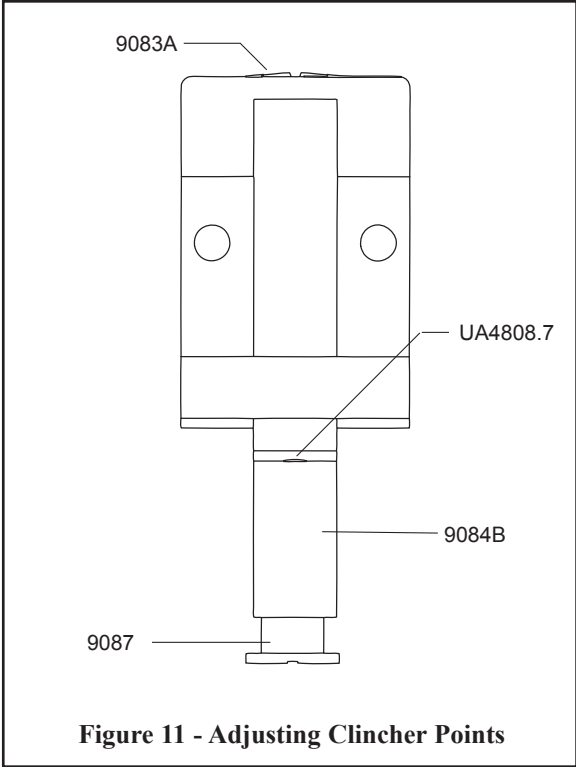

Figure 11 - Adjusting Clincher Points

Refer to the complete list of wear parts for the 26/26D style Stitcher Head, found in the back of this manual on page 50. The Clincher Points and Clincher Plates necessary for a quality stitch are specific to the crown size and wire gauge size used in each stitcher head.

2301DHD Series Head (Figure 12)

This style stitcher head does not utilize moving Clincher Points, but rather a solid Clincher Plate. The legs of each stitch are bent when the wire is pushed through the stock and hits the Clincher Plate, as opposed to the Clincher Points in moveable Clincher Plates coming up to meet the wire. The resulting stitch will not lay as flat as one clinched with moving Clincher Points though.

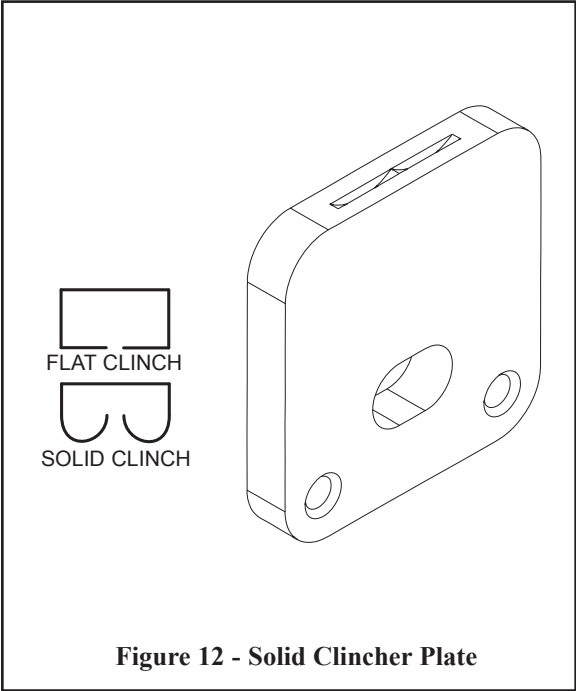

Figure 12 - Solid Clincher Plate

Maintenance

Your 26/26D Stitcher Head has been fully lubricated at the factory, but to insure continuous superior operation and a longer life of the head, the operator should be sure that the heads are lubricated regularly and carefully maintained. The operator should periodically inspect all moving parts for signs of wear and when required, replace the worn parts. Parts such as the Wire Cutters, the Grip, the Tension Pawl and the Driver are subject to wear and have been so designed to be reversible to provide duplicate cutting and gripping surfaces. If after continuous usage, the original cutting or gripping surfaces of any of these parts show signs of wear, their position in the head can be reversed, thereby providing a new surface and lengthening the life of the part. For a complete list of wear and replacement parts for your 26/26D style Stitcher Head, refer to page 50 in the back of this manual.

The following instructions are provided so that the operator will clearly understand how to lubricate the Stitcher Heads and how to identify and remove any of the parts which may need to be replaced.

Always disconnect the power supply before making any adjustments or servicing the head.

⚠ WARNING

Lubrication (Figure 13)

Use any standard S.A.E. #10 oil for lubricating the heads. Heads that are in constant operation should be lubricated daily. Heads that are operated periodically should be lubricated every five pound wire spool change or every month, whichever comes first. Usually, only a drop of oil is required at each lubrication point. Care must be taken that those parts of the head that contact the work to be stitched are free of oil. Lubricate regularly instead of excessively. Excessive oiling will result in work becoming spotted with oil. Use one drop of oil in the following lubrication points:

- the top of the Bonnet (2601B) on either side of the Wire Guide Spring Bracket (2651).
- the oil hole in the Swivel Operating Lever Hub (2154).
- the oil holes in the Face Plate (2146CA).
- on the Bender Bar Latch (9014) and on the Grip (9015).
- the opening in the Swivel Holder (2147 or 9043B).
- where the Clincher Points pivot.
- the hole in the Wire Cutter (9048) Holder.
- on the Wire Straightener Rollers (9065) and Tension Pawl (9098).

2001DHD and 2301DHD styles only

- the oil hole in the Driving Shaft Connection Link (2215)
- the diameter of the Swivel (9038A or 9038M)

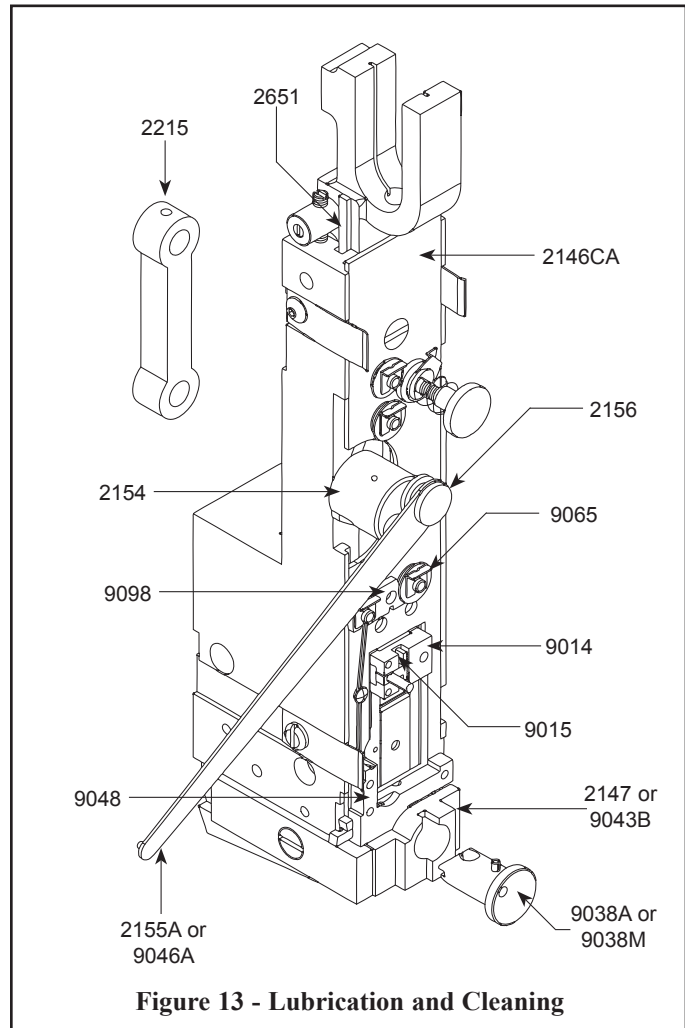

Figure 13 - Lubrication and Cleaning

Cleaning (Figure 13)

In addition to proper lubrication, routine cleaning is important for the maintenance of your 26/26D Head. The entire Head should be torn down and rebuilt every three months and the following areas should be cleaned once a month:

- **Swivel Assembly (9038A or 9038M):** remove and wash in an oil-dissolving solvent, dry and relubricate.
- **Swivel Holder (2147 or 9043B):** clean inside the Swivel hole.
- **Swivel Operating Lever Hub and Stud:** remove the Swivel Operating Spring (2155A or 9046A), Lever (2151A) and/or Lever Hub (2154). Clean the Swivel Operating Spring Stud (2156) and the hole in the Hub, relubricate and replace.

Note: Use care when replacing the Swivel Operating Lever and/or Lever Hub to avoid serious damage being done to the head.

- **Anywhere that dust, oil or pieces of wire and paper have built up** - for example: the Grip, Clincher Points and around the Wire Straightener Rollers.

Ordering Spare Parts

In time, you will need to replace some parts in your 26/26D style Stitcher Head. When this happens, first locate the needed part in one of the following diagrams. Then locate the DeLuxe/Bostitch part number and contact your Graphic Arts Representative to order the part by the part number, description and quantity.

Always power down the stitcher machine before any maintenance or adjustments are made to the stitcher head.



Replacing Spare Parts (Figure 14)

The following are some of the more common wear parts which will need to be removed and replaced in your 26/26D style Stitcher Head. Some common replacement parts do not require the Stitcher Head to be removed from the stitcher machine. These parts will be addressed first, then a more specific explanation for disassembling and replacing wear parts for the 26/26D Stitcher Head will follow.

Removing and Replacing the Wire Cutters Figure 15

The Wire Cutters (9048) have four cutting surfaces, each of which may be used by reversing the ends and positioning in the Face Plate (2132BA or 2146CA). Worn Cutters can cause poor stitch quality. To change or reverse the Wire

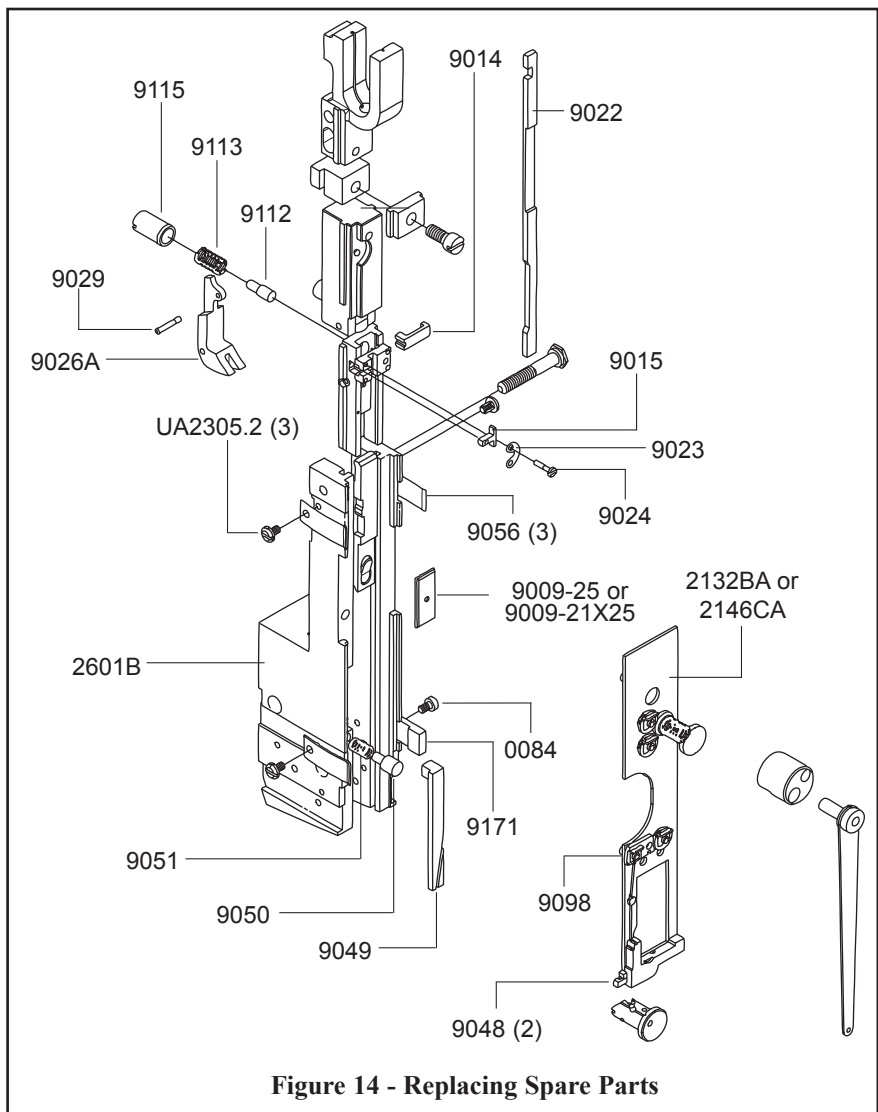

Figure 14 - Replacing Spare Parts

Cutters, remove them from the Face Plate. Loosen the Screws (UA2305.2) securing the Face Plate Clips (9056) and the Screw (0084) securing the Solid Face Plate Clip (9171). Once the clips are loosened, the Face Plate can be tilted away from the Bonnet (2601B) to remove the Wire Cutters. This may be a good time to check for wear on the Wire Cutter Operating Slide Friction Plug (9050) and Friction Plug Spring (9051) and replace if necessary. Slide the existing or new Wire Cutters into the cutter holder in the Face Plate, with the tongue of the upper Cutter facing the Face Plate and the tongue of the lower cutter facing the Wire Cutter Operating Slide. Before tightening the Face Plate Clip Screws and the Solid Face Plate Clip Screw, make sure that each Cutter has slipped into position in the Face Plate and in the Wire Cutter Operating Slide. (9049) Press the Face Plate under the Face Plate Clips and tighten the Face Plate Clip Screws. Always cycle the stitcher machine manually before switching the power on to ensure free mechanical movement. This will prevent serious damage to both machine and stitcher head.

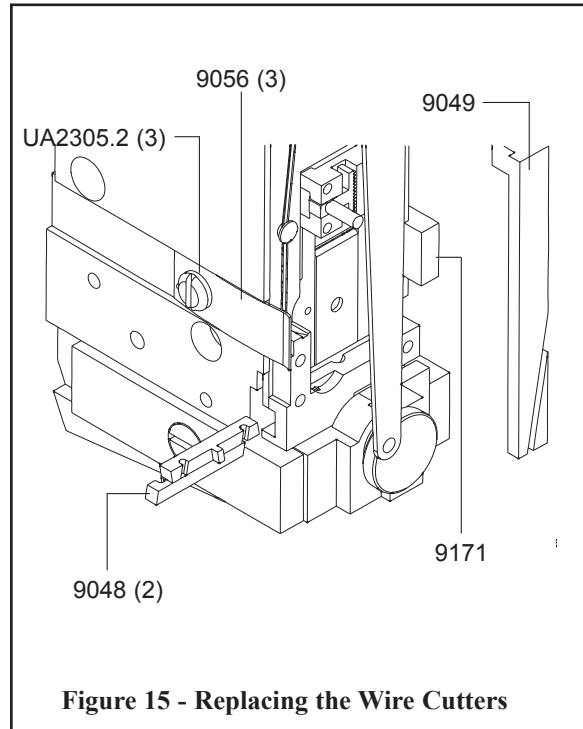

Figure 15 - Replacing the Wire Cutters

⚠ CAUTION!
 After replacing or installing new parts, rotate the Drive Pulley manually to check for free movement.

Removing and Replacing the Tension Pawl (Figure 16)

The Tension Pawl (9098) is double-ended so that when one end is worn, it can be reversed, increasing the life of the part by providing a new gripping surface. A worn Tension Pawl may cause inconsistent wire draw. To remove the Tension Pawl, disengage the Tension Pawl Spring (9134) from the Tension Pawl and remove the Wire Straightener Roll Clip (9124). Flip the Tension Pawl over so that a new surface is in contact with Wire Straightener Roller (9103) and replace the E-clip. Make sure that the Tension Pawl is under the flange in the Wire Straightener Roll before re-engaging the Tension Pawl Spring. If both ends of the Pawl are worn, replace the part.

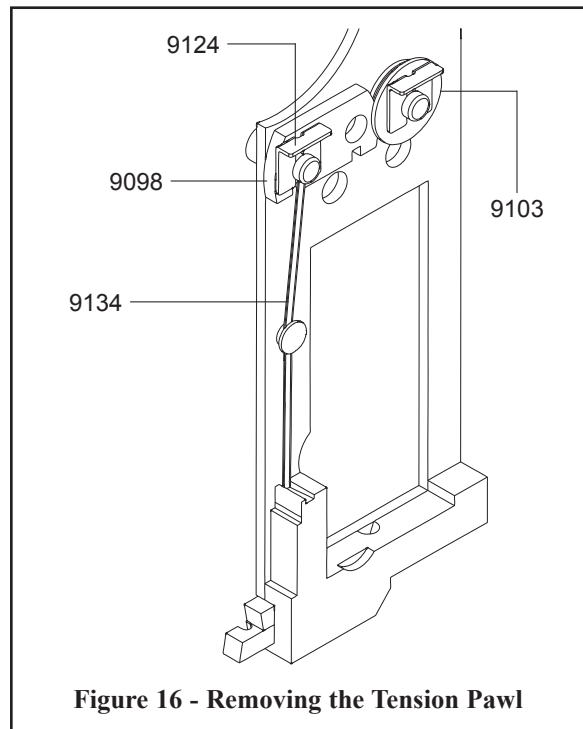

Figure 16 - Removing the Tension Pawl

Removing and Replacing the Grip (Figure 17)

The Grip (9015) can be used in two positions so that when the gripping teeth show signs of wear, it may be reversed to extend the life of the part. A worn Grip may cause inconsistent wire draw. Loosen the Grip Retaining Clip Screw (9024) and swing the Grip Retaining Clip (9023) out of the way. Remove the Grip and reverse its position within the Grip Holder. If both edges are worn, replace the part.

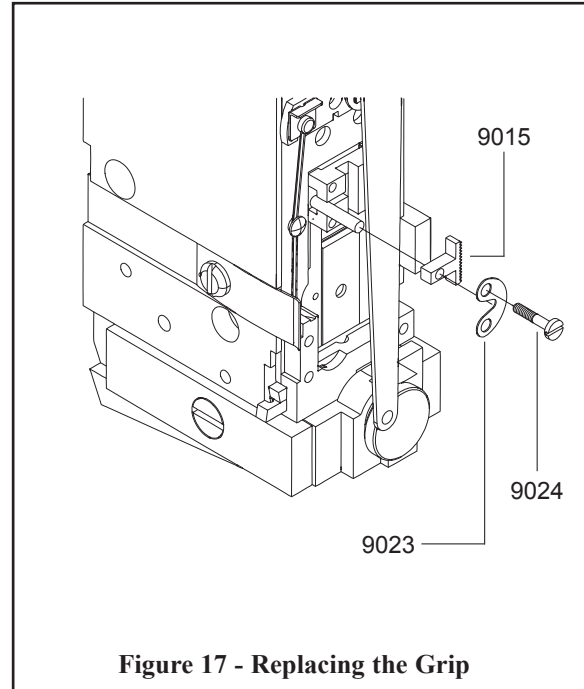

Figure 17 - Replacing the Grip

Removing and Replacing the Driver (Figure 18)

The Driver (9009-25*) is also double-ended so that when it is worn, it can be reversed to provide a new driving surface and increase the life of the part. A worn Driver end may cause poorly formed crowns. Cycle the stitcher machine manually until the Driver is at the top of its stroke. Insert the supplied Driver Release Pin (5160) into the hole in the Driver. This will depress the Driver Retaining Spring (9010) so that you will be able to push the Driver down along the Bender Bar (9013BA-25) until it can be pulled out from the bottom of the Head. Either reverse the existing Driver or replace it with a new one. Slide the Driver back up through the Bender Bar until you hear the Driver Retaining Spring click, indicating that the Driver is in its correct position.

* See pages 46-48 for a complete list of parts in variable crown and wire sizes

Disassembling the Stitcher Head (Figure 19)

Remove the 26/26D style Stitcher Head from the stitcher machine. On 2601AHD, 2601DHD and 2601EHD series heads, loosen the Bonnet Clamp Eccentric Handle (9003A) and remove the Stitcher Head from the Bonnet Clamp Block (9002). On 2001DHD and 2301DHD series heads, loosen and remove the Bonnet Stud Nut (HN1213) while supporting the Head. Remove the Head from the stitcher machine and place it on a clean work area.

Loosen, but do not remove, the Screws securing the Face Plate Retaining Clips. With the Face Plate Clips hanging loosely from the Bonnet, remove the Face Plate paying special attention to the loose Wire Cutters (9048). Remove the Wire Cutter Operating Slide, the Wire Cutter Operating Slide Friction Plug,

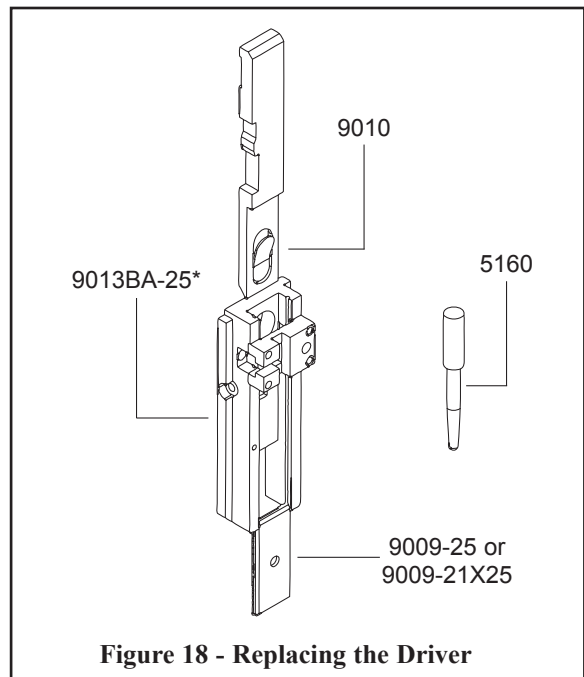

Figure 18 - Replacing the Driver

* Parts shown in outline are separated for identification purposes only.

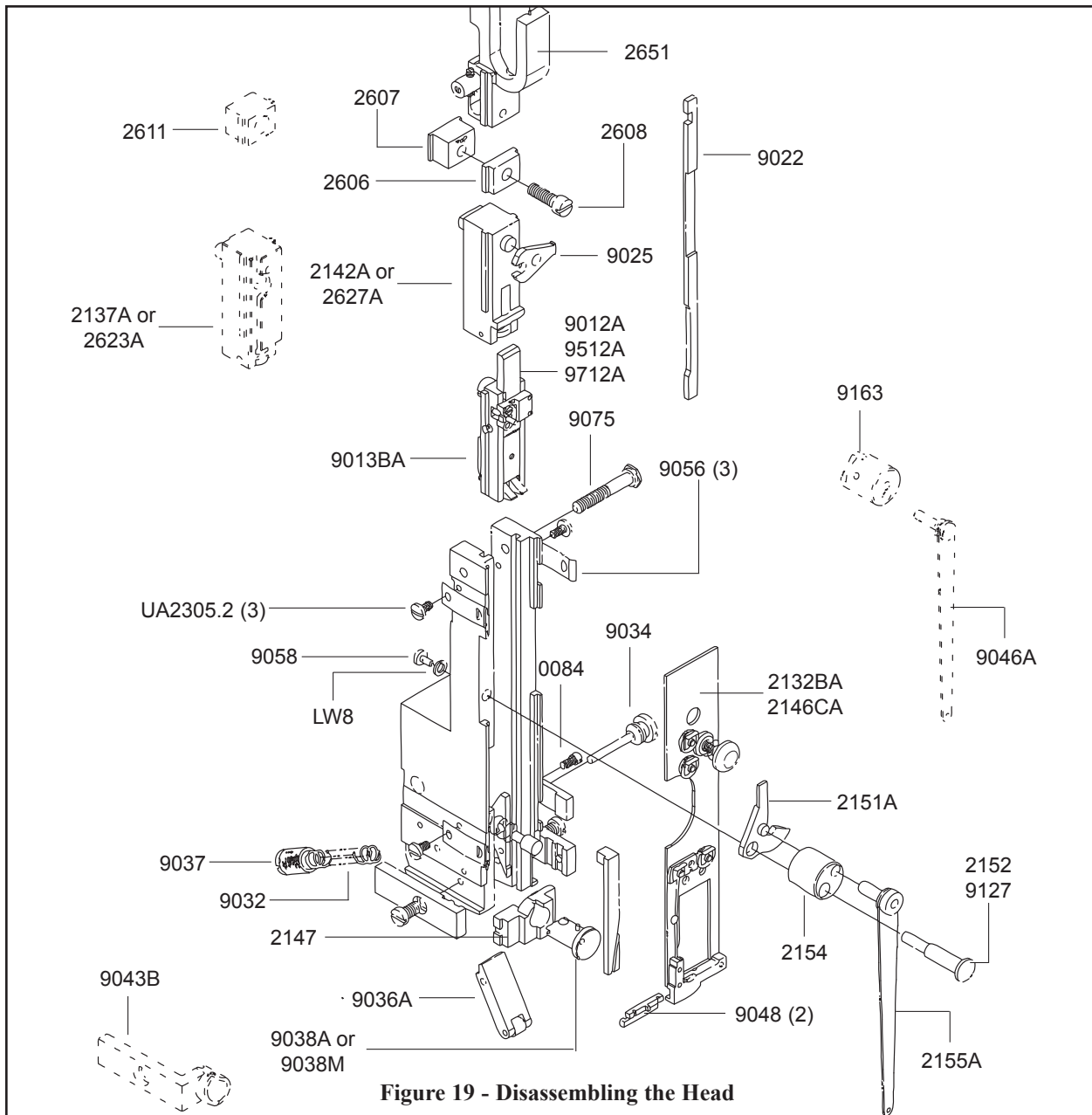

Figure 19 - Disassembling the Head

the Wire Cutter Operating Slide Friction Spring and place these pieces along side of the Bonnet. Release the Swivel (9038A or 9038M) from the Swivel Holder (2147 or 9043B) by lifting the Swivel Operating Spring (2155A or 9046A) off of the Swivel. Continue to rotate the Spring upward until it can be released from the Swivel Operating Lever Stud (2152 or 9127); until it is approximately at an 11 o'clock position. Remove the Swivel Operating Lever Hub (2154) from the Stud. The 26D style Heads have a Screw (9058) securing the Stud to the Bonnet, thus securing the Hub to the Bonnet as well. Remove this Screw in order to remove the Stud and Swivel Operating Lever (2151A). Remove any accessories at this time in addition to the Swivel Holder.

Remove the Grip Release Slide Lever (9025) and Grip Release Slide (9022) and set them aside. Loosen and remove the Wire Guide Spring Bracket Screw (9075), which will release the Wire Guide Spring Bracket (2651) from the top of the Bonnet. Loosen the Face Plate Locating Screw (2608) and slide the Face Plate Adjustment Slide Block (2611) or the Face Plate Lock Clamp (2606) and Lock Block (2607) out the top of the Bonnet. The Driving Slide Assembly Link (2142A or 2627A) will be free to slide out of the top of the Bonnet now as well as the Bender Bar Assembly (9013BA). Loosen and remove the Supporter Spring Lever Bushing (9037) as well as the Supporter Spring (9032). The Supporter Spring Lever Assembly (9036A) will now be swinging freely within the Bonnet. Loosen and remove the Supporter Spring Lever Screw (9034) to remove the Lever Assembly from the Bonnet.

Any of these assemblies can now be taken apart for cleaning or repair. The Bonnet itself can also be cleaned or checked for damage. Most common wear parts can be exchanged while the Head is still assembled though. Reassembling the Head is as simple as reversing the method used to disassemble the Head. Always turn the machine over manually anytime repairs or adjustments are made for the safety of both the operator and the Stitcher Head.

Re-assembling the Stitcher Head (Figure 19)

1. Insert the Supporter Spring Lever Screw (9034) through the Supporter Spring Lever Assembly (9036A) and into the Bonnet. Grease one end of the Supporter Spring and insert it into the Supporter Spring Lever Bushing (9037). Insert both the Spring and Bushing into the back of the Bonnet but do not tighten the Bushing completely at this point.
2. Start the Bender Bar Assembly (9013BA) into the top of the Bonnet. Hook the Driver Bar Assembly (9012A, 9512A or 9712A) in the notch of the Driving Slide Assembly Link (2137A, 2142A, 2623A or 2627A) and finish guiding both assemblies between the rails of the Bonnet.
3. Slide the Face Plate Lock Clamp (2606) and Block (2607) or the Face Plate Adjustment Slide Block (2611) into the top of the Bonnet but do not tighten the Face Plate Locating Screw at this point. Next, slide the Wire Guide Spring Bracket (2651) into the top of the Bonnet and secure it with the Wire Guide Spring Bracket Screw (9075).
4. Secure the Grip Release Slide Lever (9025) on the Pivot Pin on the Wire Guide Spring Bracket. Oil the right rail of the Bonnet slightly, engage the Lever in the notch of the Grip Release Slide (9022) and rest the Slide on the rail of the Bonnet.
5. Grease one end of the Wire Cutter Operating Slide Friction Spring (9051) and the Wire Cutter Operating Slide Friction Plug (9050) and insert both into the Bonnet. Rest the Wire Cutter Operating Slide (9049), along the left Bonnet rail, on the Friction Plug. Secure the Swivel Operating Lever (2151A), the Swivel Operating Lever Hub (2154) and the Swivel Operating Lever Stud (2152 or 9127) to the Bonnet. Verify the orientation is correct.
6. Secure the Face Plate (2132BA or 2146CA), with the Wire Cutters (9048), to the Bonnet by tightening the Screws (UA2305.2 and 0084) securing the Face Plate Clips (9056 and 9171). Make sure the internal assemblies move freely before mounting the Head on a Machine.

Troubleshooting (Figure 20)

The quality and quantity of work that can be produced with the 26/26D Stitcher Head is dependent upon the operator making all adjustments as accurately as possible and carefully maintaining the head. The cause of staple imperfections usually can be traced to inaccurate settings or normal wear of moving parts. In the event of trouble of this nature occurring, the operator can, by referring to the following troubleshooting chart, quickly locate and remedy the cause or causes of the trouble. The following is a brief list of problems and solutions which should cover the majority of situations encountered when stitching with the 26/26D Stitching Head.





	<p>PROBLEM: Left Leg Short SOLUTION: Lengthen the left leg. (See page 14) Check the Grip for wear and clean, rotate or replace it if needed. (See page 22)</p>
	<p>PROBLEM: Right Leg Short SOLUTION: Shorten the left leg to match the right leg, then adjust both legs to desired length by adjusting the Face Plate. (See page 15)</p>
	<p>PROBLEM: Corner Buckled SOLUTION: Check the Driver (9009-wire size) for a chipped corner and rotate or replace it if needed. (See page 22) Check the tensile strength of the wire or use thicker wire.</p>
	<p>PROBLEM: Leg(s) Buckled SOLUTION: If the ends of an unformed piece of wire are not smooth, the Wire Cutters (9048) are worn. Check for wear and rotate or replace if needed. (See page 20) Make sure the correct wire size is being used and that the wire is straight.</p>
	<p>PROBLEM: Crown Bent or Buckled SOLUTION: Check Supporter Spring (9032) tension, adjust the Supporter Spring Lever Bushing or replace the Spring if needed. Check for correct wire size being used. Check for correct work thickness setting. Make sure there is not too much chamfer on the Swivel or that it is worn.</p>

Figure 20 - Troubleshooting

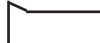

PROBLEM: Partially Formed Stitches

SOLUTION: Replace the worn Driver Bar Latch (9014) or Driver Bar (9012A). The Grip Spring (9019) could be worn or broken, replace it.

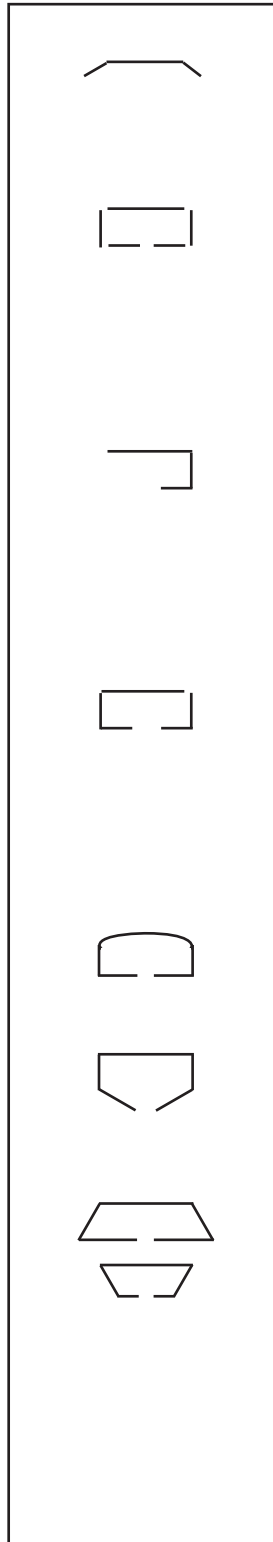
PROBLEM: Stitch in Pieces or Right or Left Leg Sheared Off

SOLUTION: Clean and lubricate Swivel (9038A or 9038M). (See page 19) Loosen the Swivel Holder Screw and correct the alignment between the Swivel Holder and the Bender Bar. If problem persists, file the forming corner of the Swivel slightly with a honing stone.

PROBLEM: Left Leg Missing

SOLUTION: Clean the Grip (9015). Reverse or replace the part if needed. (See page 22) Make sure the Wire Straightener Rollers are not set too tight. Make sure the Tension Pawl is not worn and is pivoting correctly. (See page 21)

PROBLEM: Corner of stitch broken or nearly cut through

SOLUTION: File the forming corner of the Swivel slightly with a honing stone if too sharp. Lower Clincher Points (9083) if too high. (See page 16) Loosen the Swivel Holder Screw and correct the alignment between the Swivel Holder and the Bender Bar.

PROBLEM: Corners of the Crown are Rounded

SOLUTION: Replace the worn Swivel (9038A or 9038M).

PROBLEM: Loose Clinch

SOLUTION: Check thickness setting for work or raise Clincher Points (9083). (See page 17)

PROBLEM: Legs are Spread or Contracted

SOLUTION: Re-adjust the Wire Straightener Eccentrics to improve straightness. (See page 13) Check the Wire Cutters for wear and rotate or replace. (See page 20) Check the Bender Bar (9013BA-wire size) for wear in the grooves and replace if necessary.

PROBLEM: No wire being drawn

SOLUTION: Lower the Face Plate. (See page 15)

Figure 20 - Troubleshooting

Bonnet Sub-Assembly - "D" Style

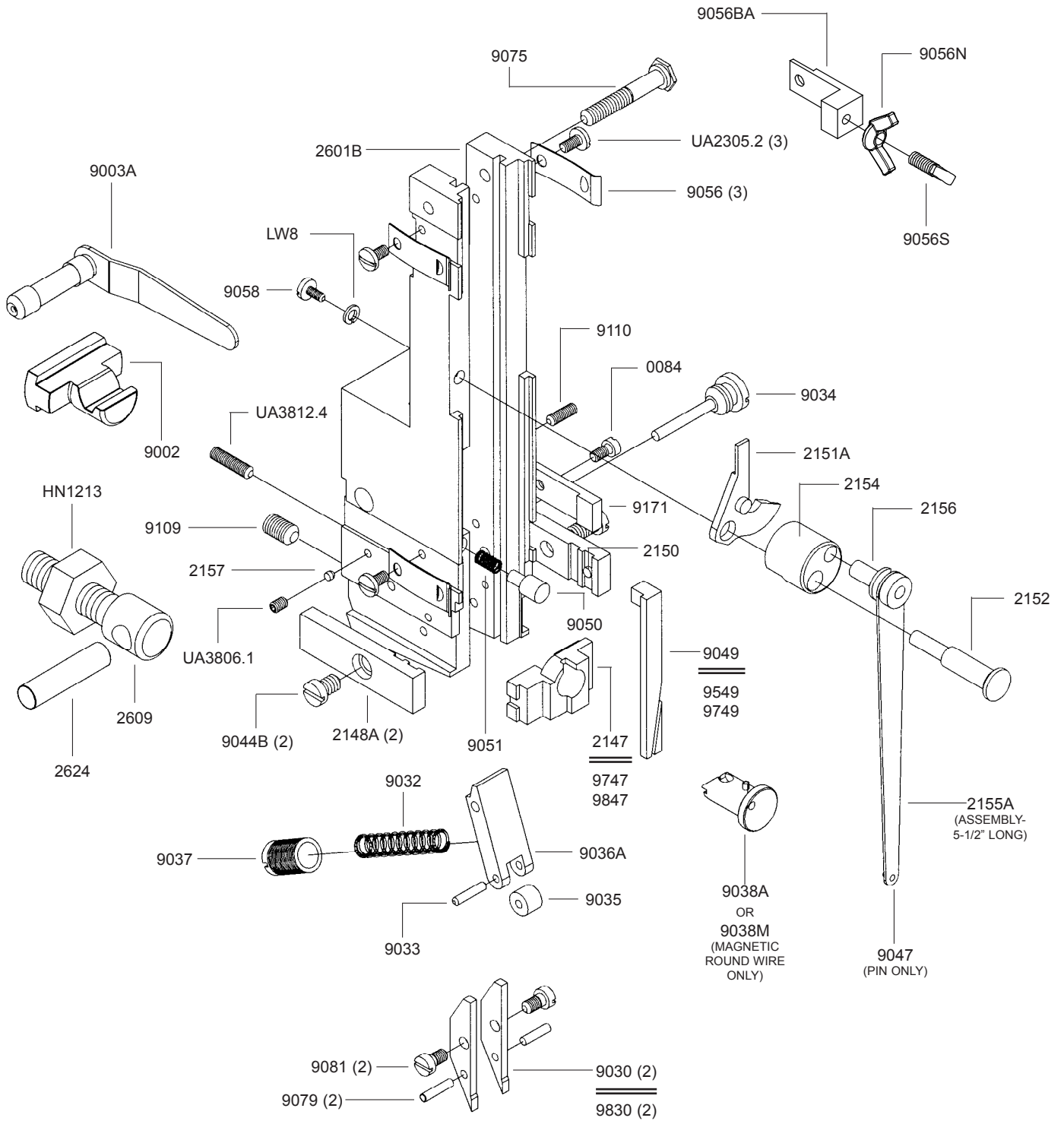

The 26/26D Stitcher Head

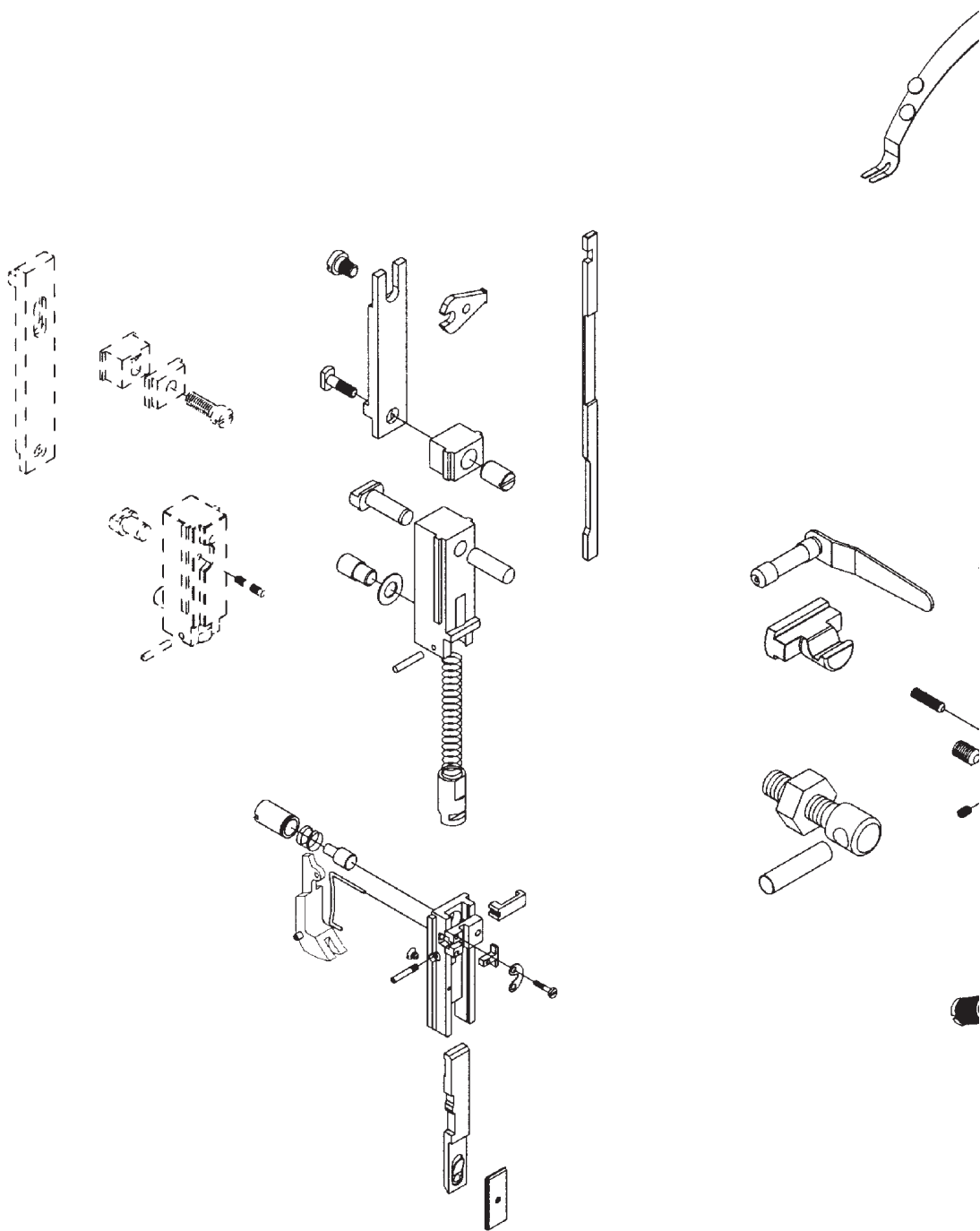

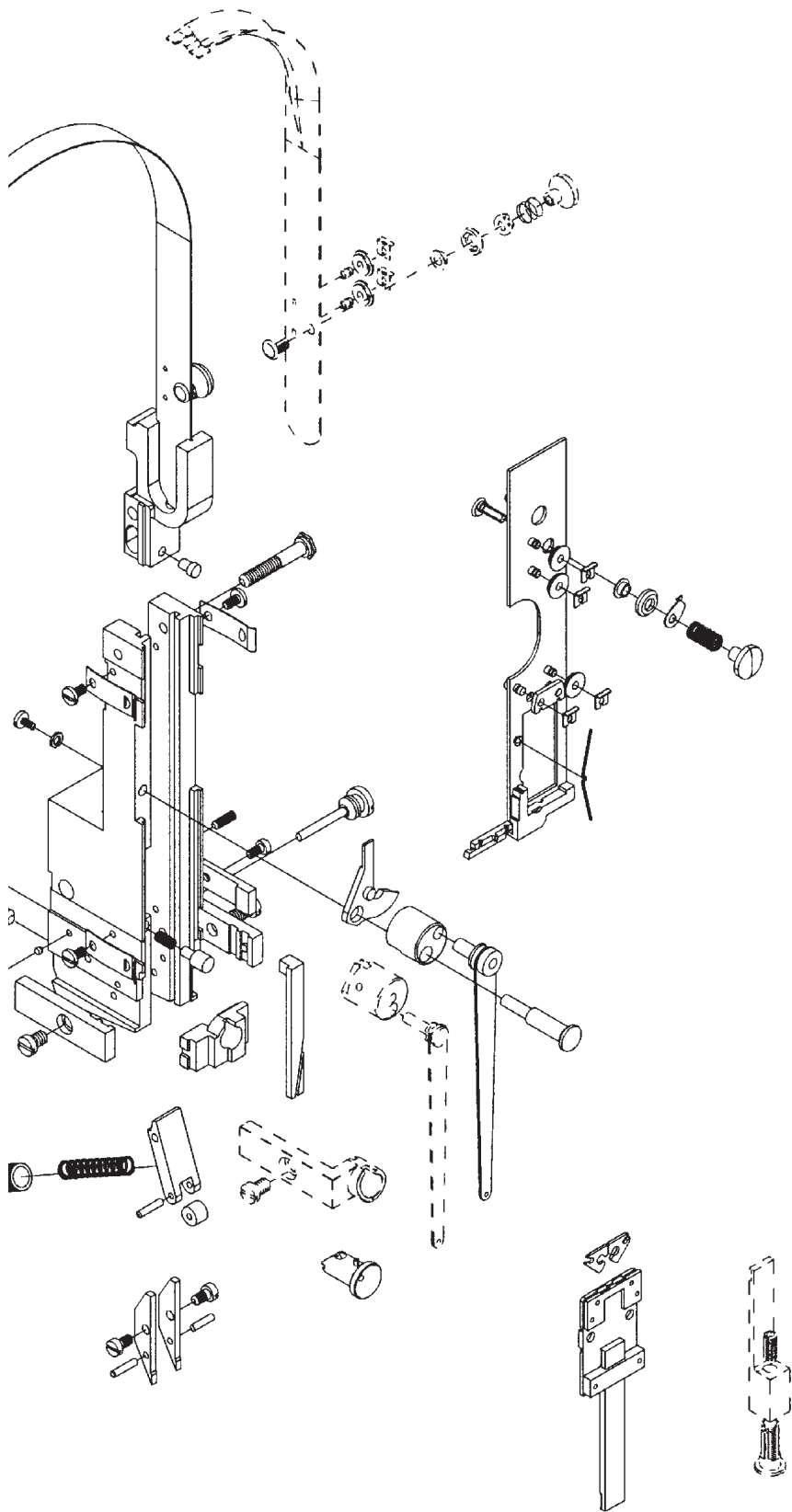

Bonnet Sub-Assembly - "A" Style

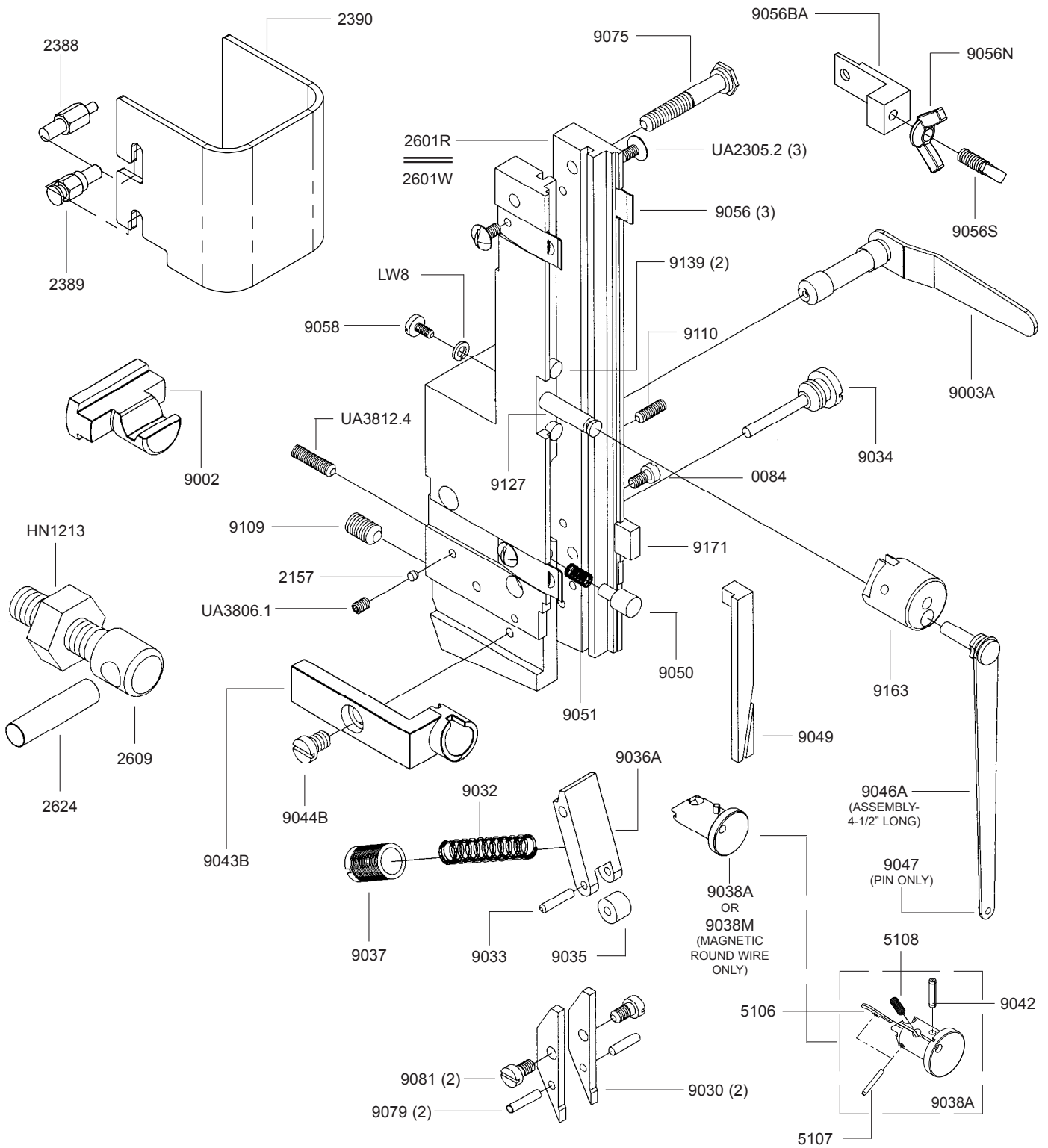

Face Plate Assembly

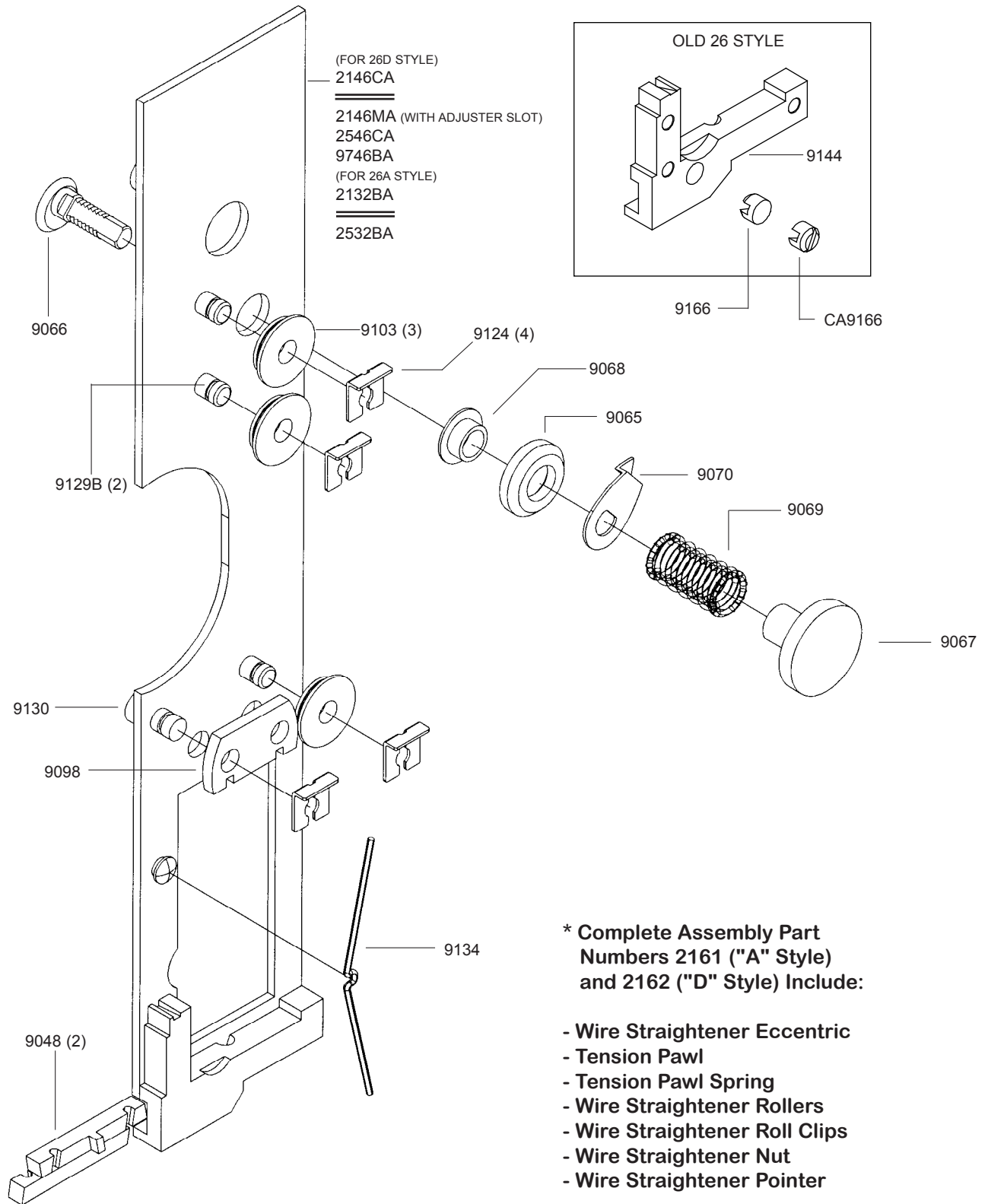

Driving Slide Assembly - "D" Style

For Bostitch 17-AW
and No. 17 Machines

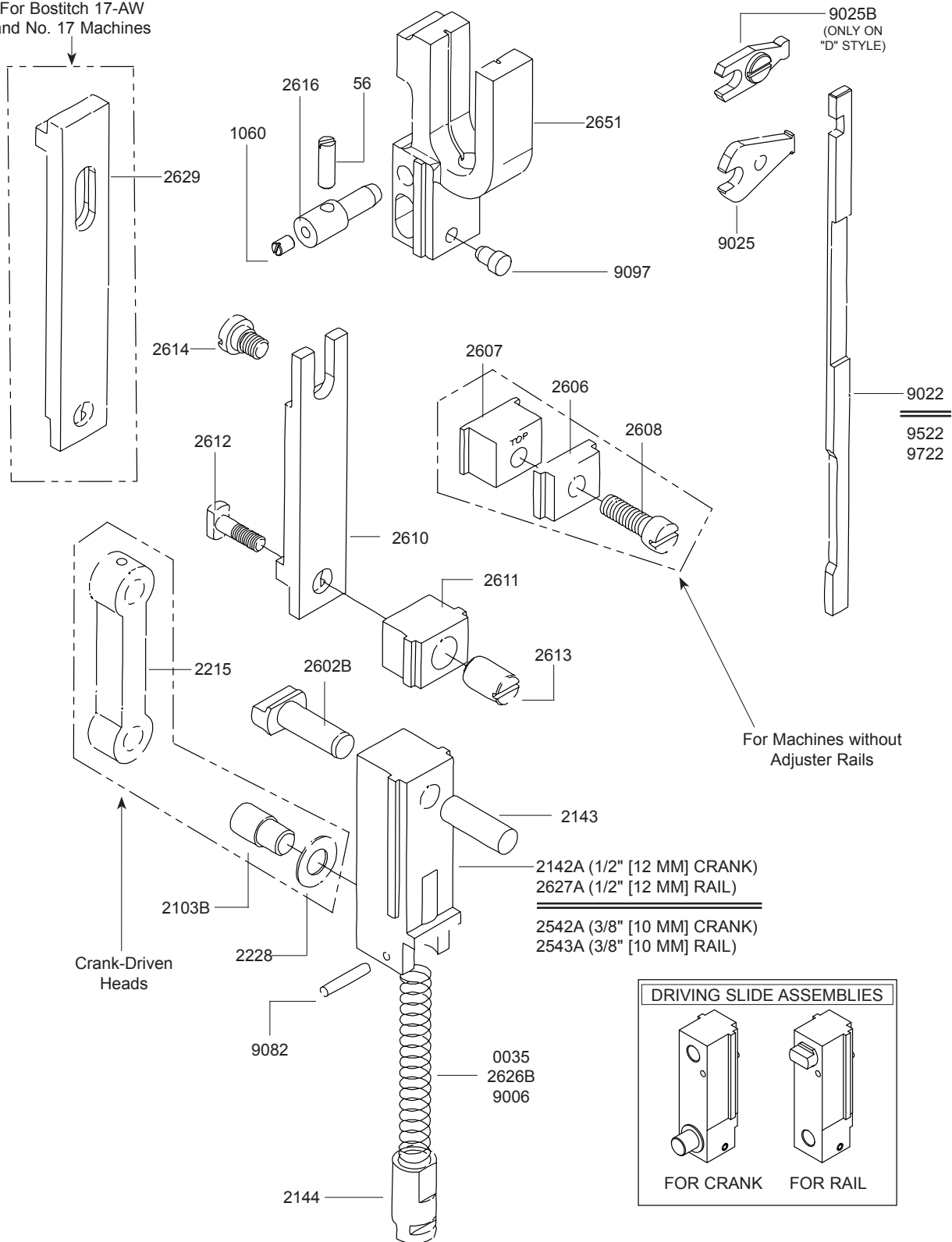

Driving Slide Assembly - "A" Style

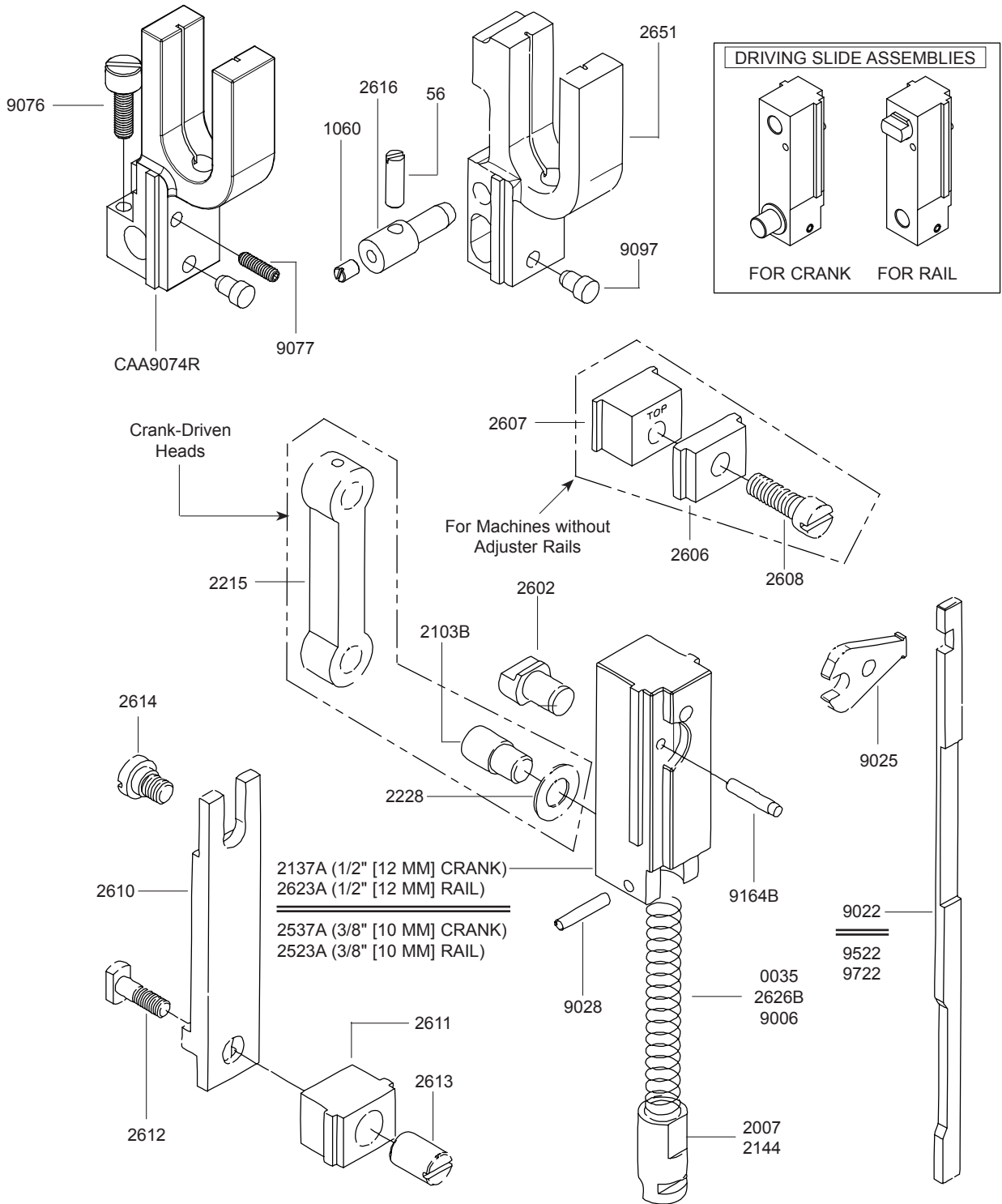

Bender Bar Assembly

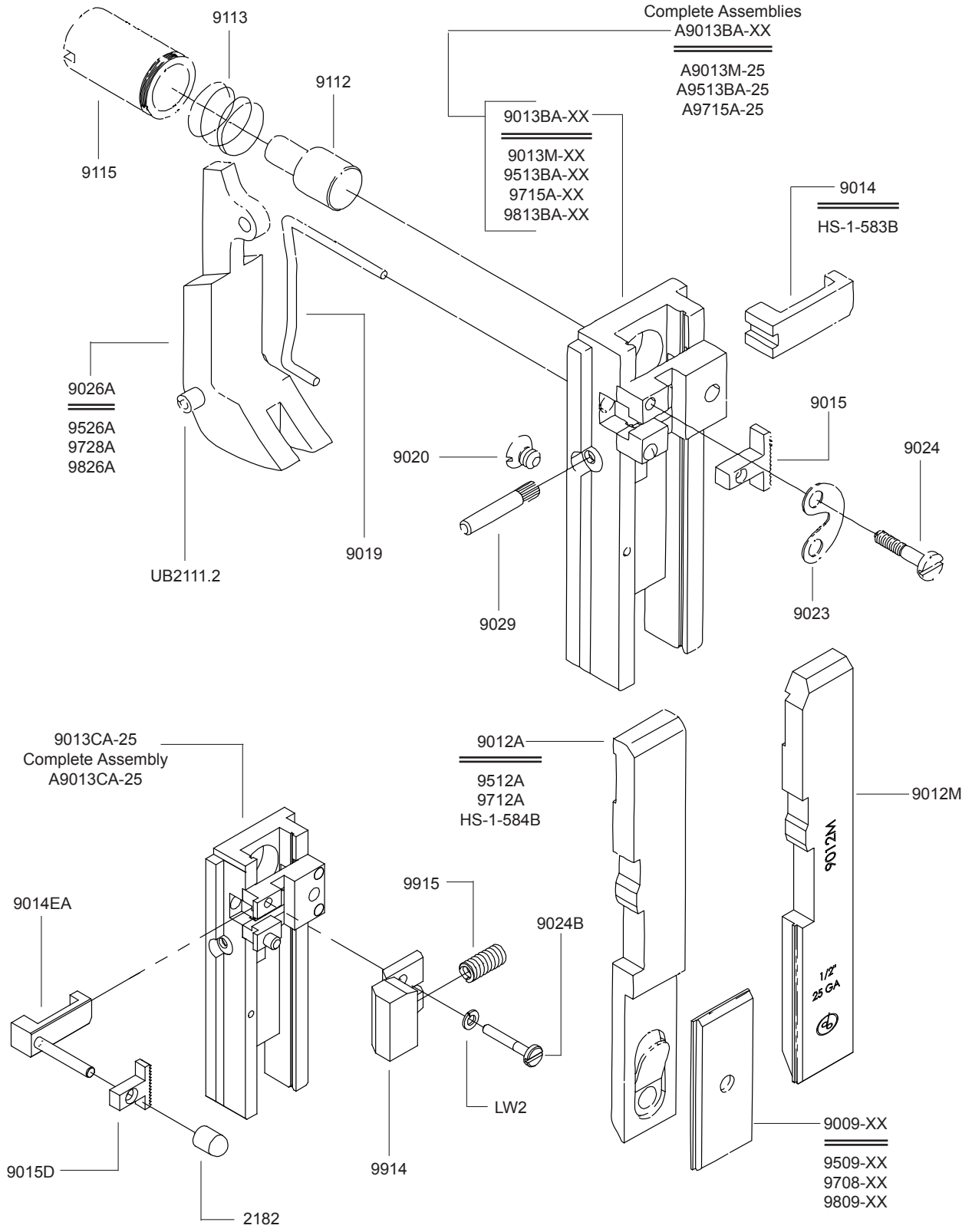

Wire Guide Bracket and Spring

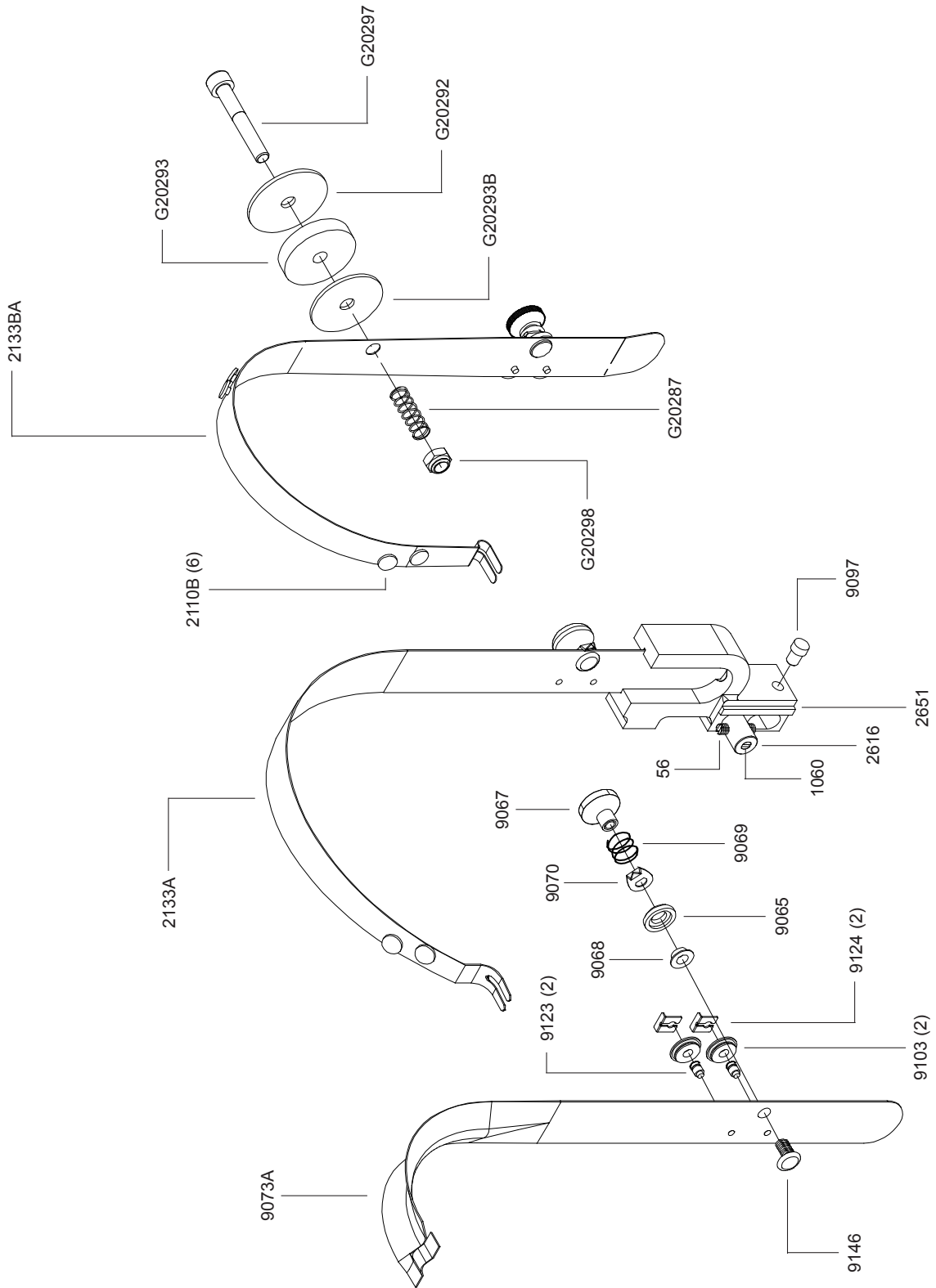

Clincher Plate Assemblies

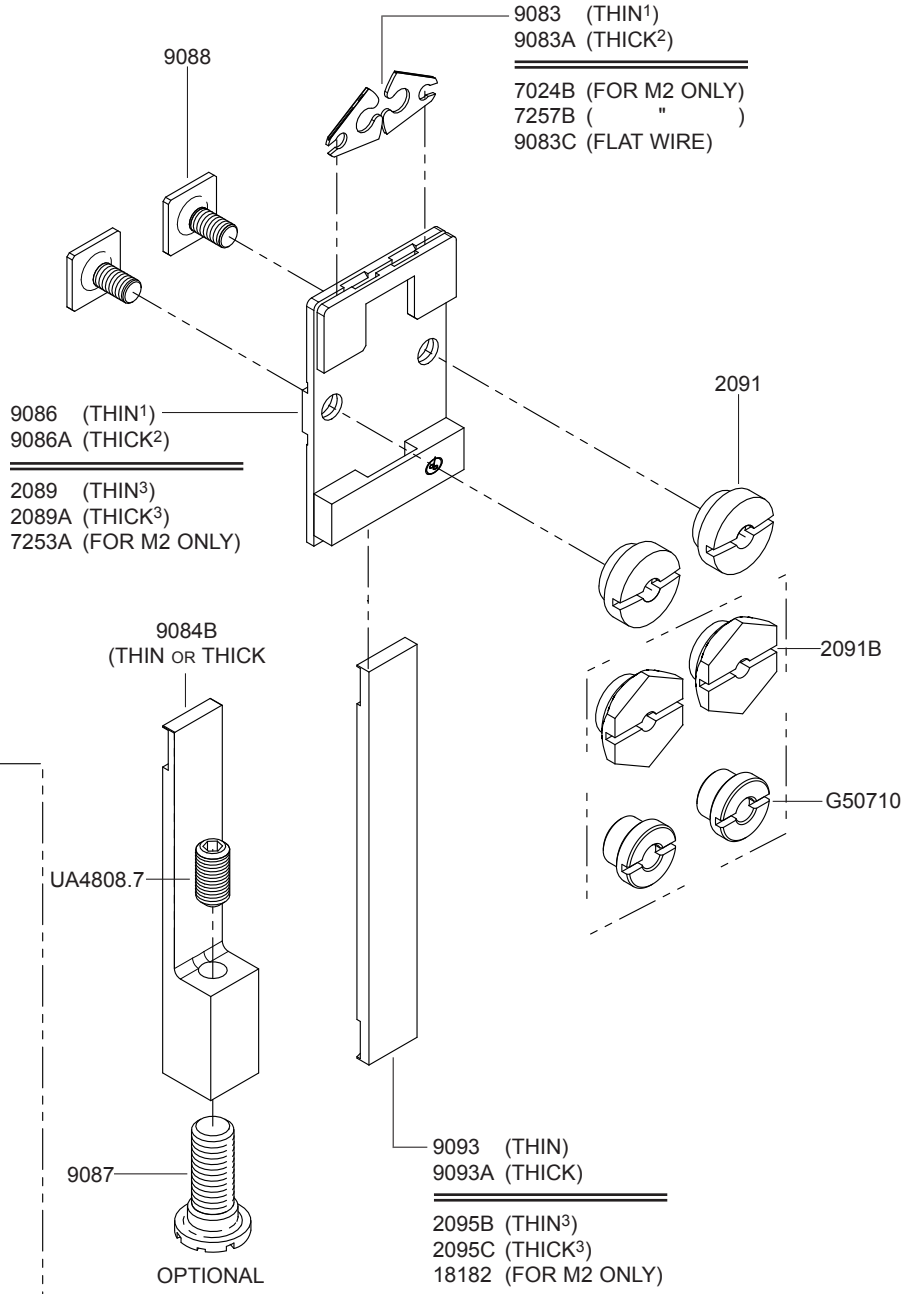
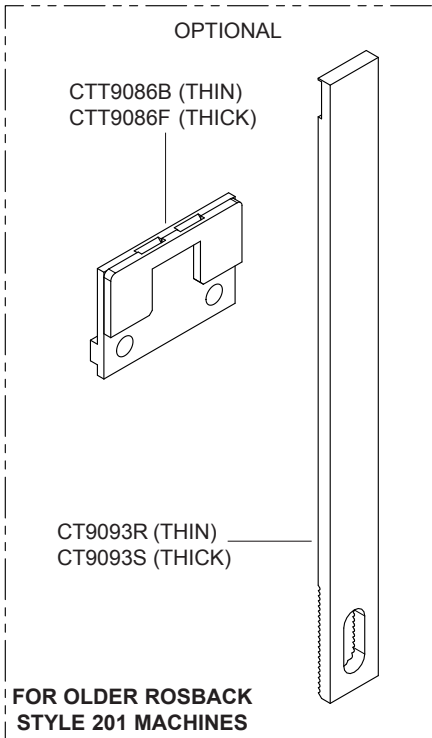
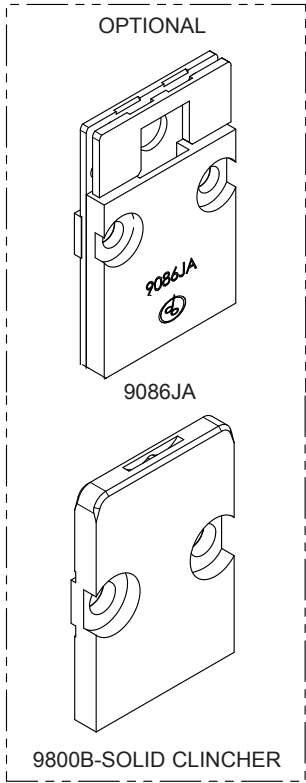

1- 1/32" [0.75MM] WIDE
2- 1/16" [1.5MM] WIDE
3- FOR BOSTITCH #2 OR 2AW. ALSO USED ON
ACME/CHAMPION, INTERLAKE/ISP MODEL A.

Part Number / Description Cross-Reference

0035	Driving Slide Spring - Heavy	1	2228	Driving Slide Pin Washer	1
0084	Solid Face Plate Clip Screw	1	2523A	Driving Slide Assembly 3/8 (Lug)	1
1060	Wire Guide Adjust Binder Screw	1	2532BA	Face Plate - 3/8 (26A)	1
18182	Clincher Slide	1	2537A	Driving Slide Assembly 3/8 (Link)	1
18183	Clincher Slide Adjusting Block	1	2542A	Driving Slide Assembly 3/8 (Link)	1
18184	Clincher Slide Block Clamp	1	2543A	Driving Slide Assembly 3/8 (Lug)	1
18186	Clincher Slide Adjusting Screw	1	2546CA	Face Plate Assembly 3/8 (26D)	1
2007	Driving Slide Spring Plunger	1	2601B	Bonnet Sub-Assembly (26D)	1
2089	Clincher Plate - Thin	1	2601R	Bonnet Sub-Assembly (26A)	1
2089A	Clincher Plate - Thick	1	2601W	Bonnet Sub-Assembly (Watkiss)	1
2091	Clincher Plate Binder Nut	2	2602	Driving Slide Lug (26A)	1
2095B	Clincher Slide - Thin	1	2602B	Driving Slide Lug (26D)	1
2095C	Clincher Slide - Thick	1	2606	Face Plate Locating Clamp	1
2103B	Driving Slide Pin	1	2607	Face Plate Lock Block	1
2132BA	Face Plate 1/2 (26A)	1	2608	Face Plate Lock Screw	1
2133A	Wire Guide Spring Assembly	1	2609	Bonnet Binder Stud	1
2133BA	Wire Guide Spring Asy w/ Oiler Felt	1	2609B	Bonnet Binder Stud (Metric)	1
2137A	Driving Slide Assembly Link (26A)	1	2610	Face Plate Adjust Slide	1
2142A	Driver Slide Assembly Link (26D)	1	2611	Face Plate Adjust Slide Block	1
2143	Driving Slide Swivel Operating Pin	1	2612	Face Plate Adjust Slide Stud	1
2144	Driving Slide Plunger	1	2613	Face Plate Adjust Slide Nut	1
2145	Supporter Guide Plate Screw	1	2614	Face Plate Adjust Slide Stud	1
2146CA	Face Plate 1/2 (26D)	1	2616	Wire Guide Spring Adjust Screw Stud	1
2146MA	Face Plate 1/2 w/Adjuster Slot (26D)	1	2623A	Driving Slide Assembly Link (26A)	1
2147	Swivel Holder (26D)	1	2624	Bonnet Stud Pin	1
2148A	Swivel Holder Clamp	2	2626B	Driving Slide Spring	1
2150	Swivel Holder Dowel	1	2627A	Driving Slide Assembly (26D)	1
2151A	Swivel Operating Lever	1	2629	Face Plate Adjustment Slide	1
2152	Swivel Operating Lever Stud	1	2651	Wire Guide Spring Bracket	1
2154	Swivel Operating Lever Hub	1	5037	Retaining Clip Rivet	1
2155A	Swivel Operating Spring	1	5160	Driver Release Pin	1
2156	Swivel Operating Spring Stud	1	56	Wire Guide Spring Bracket Screw	1
2157	Supporter Lever Lock Shoe	1	7024B	Clincher Point, Flat - 1/2	2
2161	Complete Face Plate Asy 1/2 (26A)	1	7253A	Clincher Plate - 1/2	1
2162	Complete Face Plate Asy 1/2 (26D)	1	7257B	Clincher Point, Round - 1/2	2
2182	Cap	1	9002	Bonnet Clamp Block	1
2215	Driving Shaft Connector	1	9003A	Bonnet Clamp Handle	1

Part Number / Description Cross-Reference

9006	Driving Slide Spring - Light	1	9049	Wire Cutter Operating Slide	1
9009-XX	Driver - 1/2 - Wire Size	1	9050	Wire Cutter Oper Slide Friction Plug	1
9010	Retaining Clip	1	9051	Wire Cutter Oper Slide Friction Spring	1
9012A	Driver Bar Assembly - 1/2	1	9056	Face Plate Retaining Clip	3
9012M	Driver Bar	1	9056BA	Face Plate Clamp Block Assembly	1
9013BA-XX	Bender Bar - 1/2 - Wire Size	1	9056N	Face Plate Clamp Block Nut	1
9013CA-25	B/Bar Asy 1/2, External Grip Spring	1	9056S	Face Plate Clamp Block Screw	1
9014	Latch	1	9058	Swivel Operating Lever Screw	1
9014EA	Latch Assembly	1	9065	Wire Straightener Eccentric Roller	1
9015	Grip	1	9066	Wire Straightener Eccentric	1
9015D	Grip	1	9067	Wire Straightener Eccentric Nut	1
9019	Grip Spring	1	9068	Wire Straightener Eccentric Bushing	1
9020	Grip Spring Retaining Screw	1	9069	Wire Straightener Eccentric Spring	1
9022	Grip Release Slide	1	9070	Wire Straightener Eccentric Pointer	1
9023	Grip Retaining Clip	1	9073A	Wire Guide Spring Assembly	1
9024	Grip Retaining Clip Screw	1	9075	Wire Guide Spring Bracket Screw	1
9024B	Grip Spring Housing Screw	1	9076	Wire Guide Spring Brkt Adjust Screw	1
9025	Grip Release Slide Lever	1	9077	Wire Guide Spring Brkt Set Screw	1
9025B	Grip Release Slide Adjust. Lever Assy.	1	9078	Supporter Guide Plate Dowel	2
9026A	Supporter Assembly - 1/2	1	9079	Supporter Guide Plate Dowel	2
9028	Driving Slide Spring Lock Pin	1	9081	Screw	1
9029	Supporter Pivot Pin	1	9083	Clincher Point, Thin, Round	2
9030	Supporter Guide Plate	2	9083A	Clincher Point, Thick, Round	2
9032	Supporter Spring	1	9083C	Clincher Point, Thick, Flat	2
9032B	Supporter Spring - Heavy	1	9083-21	Clincher Point, Thin, Flat	2
9033	Dowel Pin	1	9084B	Adjustable Clincher Slide	1
9034	Supporter Spring Lever Screw	1	9086	Clincher Plate, Thin	1
9035	Supporter Spring Lever Roll	1	9086A	Clincher Plate, Thick	1
9036A	Supporter Spring Lever Assembly	1	9086JA	Clincher Plate, Thick	1
9037	Supporter Spring Lever Bushing	1	9087	Clincher Slide Adjusting Screw	1
9038A	Swivel Assembly - 1/2	1	9088	Clincher Plate Binder Bolt	2
9038M	Swivel Magnetic - 1/2	1	9093	Clincher Slide, Thin	1
9043B	Swivel Holder (26A)	1	9093A	Clincher Slide, Thick	1
9044B	Swivel Holder Screw	2	9097	Grip Release Lever Pin	1
9046A	Swivel Operating Spring (26A)	1	9098	Tension Pawl	1
9047	Swivel Operating Spring Pin	1	9103	Wire Straightener Roller	3
9048	Wire Cutter	2	9109	Bonnet Alignment Screw	1

Part Number / Description Cross-Reference

9110	Bonnet Screw Binder	1	9793	Clincher Slide, Thin - 5/16	1
9112	Bender Bar Friction Plug	1	9809-XX	Driver 5/8	1
9113	Bender Bar Friction Spring	1	9813BA-XX	Bender Bar - 5/8	1
9115	Bender Bar Friction Bushing	1	9826A	Supporter Assembly - 5/8	1
9123	Wire Straightener Roll Stud	3	9830	Supporter Guide Plate - 5/8	2
9124	Wire Straightener Roll Clip	4	9838A	Swivel Assembly 5/8	1
9127	Swivel Operating Lever Stud	1	9838M	Swivel Magnetic 5/8	1
9129B	Swivel Operating Spring Stud	1	9847	Swivel Holder 5/8	1
9130	Tension Pawl Rivet	1	9914	Grip Spring Housing	1
9134	Tension Pawl Spring	1	9915	Bender Bar Spring	1
9139	Swivel Operating Stop Pin	2	A9013BA-XX	Bender Bar Asy Complete 1/2	1
9144C	Wire Cutter Holder	1	A9013CA-25	B/Bar Asy Complete 1/2, Ext. Grip	1
9146	Wire Straightener Eccentric	1	A9086	Complete Clincher Plate Asy, Tn, Rd	1
9163	Swivel Operating Hub	1	A9086A	Complete Clincher Plate Asy, Tk, Rd	1
9164B	Driving Slide Swivel Operating Pin	1	A9513BA-25	Complete Bender Bar Assembly 3/8	1
9166	Wire Cutter Locating Pin	1	A9715BA-25	Bender Bar Asy Complete 5/16	1
9171	Solid Face Plate Clip	1	CA9166	Wire Cutter Locating Screw	1
9193A	Adjustable Clincher Plate Asy - Thick	1	CAA9074R	Wire Guide Spring Bracket	1
9509-XX	Driver 3/8	1	G50102	Bolt Mount Mounting Block	1
9513BA-XX	Bender Bar 3/8	1	G50394	Flat Washer - M8	4
9512A	Driver Bar Assembly 3/8	1	G50710	Clincher Plate Nut	2
9522	Grip Release Slide 3/8	1	G50716	Mounting Block Handle	1
9526A	Supporter Assembly 3/8	1	HN1213	Bonnet Stud Nut	1
9538A	Swivel Assembly 3/8	1	HN3816	Hex Nut	1
9549	Wire Cutter Operating Slide 3/8	1	HS-1-583B	Latch - McCain S.S.	1
9708-XX	Driver - 5/16	1	HS-1-584B	Driver Bar - McCain S.S.	1
9712A	Driver Bar Assembly - 5/16	1	LW8	Lock Washer	1
9715A-XX	Bender Bar 5/16	1	LW38	Lock Washer 3/8	1
9722	Grip Release Slide 5/16	1	PW38	Washer 3/8	1
9728A	Supporter Assembly 5/16	1	UA1428.1	Screw 1/4 - 28 x 1/4	1
9737A	Swivel Assembly 5/16	1	UA2305.2	Face Plate Retaining Clip Screw	3
9745	Wire Cutter 5/16	2	UA3216.4	Screw 10 - 32 x 7/8	2
9746BA	Face Plate Assembly 5/16	1	UA3806.1	Supporter Lever Lock Screw	1
9747	Swivel Holder 5/16	1	UA3812.4	Supporter Lever Stop Screw	1
9749	Wire Cutter Operating Slide 5/16	1	UA4808.7	Clincher Slide Adjuster Lock Screw	1
9783	Clincher Point, Thin 5/16	2	UB2111.2	Supporter Guide Pin	1
9786A	Clincher Plate, Thin, 5/16	1			

Variable Crown and Wire Sizes

Description	Crown	Wire Size	Part Number
Bender Bar Assembly	5/16	25	9715A-25
Bender Bar Assembly	5/16	21x25	9715A-2125
Bender Bar Assembly	3/8	25	9513BA-25
Bender Bar Assembly	3/8	21x25	9513BA-2125
Bender Bar Assembly	1/2	25	9013BA-25
Bender Bar Assembly	1/2	23	9013BA-23
Bender Bar Assembly	1/2	21	9013BA-21
Bender Bar Assembly	1/2	21x25	9013BA-2125
Bender Bar Assembly	5/8	25	9813BA-25
Bender Bar Assembly	5/8	21	9813BA-21
Clincher Plate - Thin (1/32")	5/16	All	9786A
Clincher Plate - Thin (1/32")		All	9086
Clincher Plate - Thick (1/16")		All	9086A
Clincher Plate - Thick (1/16")		All	9086JA
Clincher Plate - Thick (1/16")		All	9800B
Clincher Plate - Thin (1/32")		All	2089
Clincher Plate - Thick (1/16")		All	2089A
Clincher Plate - M-Series		All	7253A
Clincher Plate - Thin (1/32")		All	CTT9086B
Clincher Plate - Thick (1/16")		All	CTT9086F
Clincher Point - Thin (1/32")	5/16	Rd Wire Only	9783
Clincher Point - Thin (1/32")		Rd Wire Only	9083
Clincher Point - Thick (1/16")		Rd Wire Only	9083A
Clincher Point - Thick (1/16")		Flat Wire Only	9083C
Clincher Point - M-Series		Flat Wire Only	7024B
Clincher Point - M-Series		Rd Wire Only	7257B

Variable Crown and Wire Sizes

Description	Crown	Wire Size	Part Number
Clincher Slide - Thin (1/32")	5/16	Rd Wire Only	9793
Clincher Slide - Thin (1/32")	3/8	Rd Wire Only	2095B
Clincher Slide - Thin (1/16")	3/8	Rd Wire Only	2095C
Clincher Slide - Thin (1/32")	3/8	Rd Wire Only	9093
Clincher Slide - Thin (1/16")	3/8	Rd Wire Only	9093A
Clincher Slide - M-Series	1/2	Rd and Flat Wire	18182
Clincher Slide - Thin (1/32")	1/2	Rd and Flat Wire	9093
Clincher Slide - Thick (1/16")	1/2	Rd and Flat Wire	9093A
Clincher Slide - Thin (1/32")	1/2	Rd and Flat Wire	2095B
Clincher Slide - Thick (1/16")	1/2	Rd and Flat Wire	2095C
Clincher Slide - Thin (1/32")	1/2	Rd and Flat Wire	CT9093R
Clincher Slide - Thick (1/16")	1/2	Rd and Flat Wire	CT9093S
Clincher Slide - Thin (1/32")	5/8	Rd and Flat Wire	9093
Clincher Slide - Thick (1/16")	5/8	Rd and Flat Wire	9093A
Driver	5/16	25	9708-25
Driver	5/16	21x25	9708-2125
Driver	3/8	25	9509-25
Driver	3/8	21x25	9509-2125
Driver	1/2	25	9009-25
Driver	1/2	23	9009-23
Driver	1/2	21	9009-21
Driver	1/2	21x25	9009-2125
Driver	5/8	25	9809-25
Driver	5/8	21	9809-21
Driver Bar Assembly	5/16	All	9712A
Driver Bar Assembly	3/8	All	9512A
Driver Bar Assembly	1/2	All	9012A
Driver Bar Assembly	5/8	All	9012A
Driving Slide Asy - Crank	5/16	All	2142A
Driving Slide Asy - Rail	5/16	All	2627A
Driving Slide Asy - Rail	3/8	All	2523A
Driving Slide Asy - Crank	3/8	All	2537A
Driving Slide Asy - Crank	3/8	All	2542A
Driving Slide Asy - Rail	3/8	All	2543A
Driving Slide Asy - Crank	1/2	All	2137A
Driving Slide Asy - Crank	1/2	All	2142A
Driving Slide Asy - Rail	1/2	All	2623A
Driving Slide Asy - Rail	1/2	All	2627A
Driving Slide Asy - Crank	5/8	All	2142A
Driving Slide Asy - Rail	5/8	All	2627A

Variable Crown and Wire Sizes

Description	Crown	Wire Size	Part Number
Face Plate Assembly - 26D	5/16	All	9746BA
Face Plate Assembly - 26A	3/8	All	2532BA
Face Plate Assembly - 26D	3/8	All	2546CA
Face Plate Assembly - 26A	1/2	All	2132BA
Face Plate Assembly - 26D	1/2	All	2146CA
Face Plate Assembly - 26D	1/2	All	2146MA
Face Plate Assembly - 26A	5/8	All	2132BA
Face Plate Assembly - 26D	5/8	All	2146CA
Grip Release Slide	5/16	All	9722
Grip Release Slide	3/8	All	9522
Grip Release Slide	1/2	All	9022
Grip Release Slide	5/8	All	9022
Supporter	5/16	All	9728A
Supporter	3/8	All	9526A
Supporter	1/2	All	9026A
Supporter	5/8	All	9826A
Supporter Guide Plate	5/16	All	9030
Supporter Guide Plate	3/8	All	9030
Supporter Guide Plate	1/2	All	9030
Supporter Guide Plate	5/8	All	9830
Supporter Guide Plate Dowel	5/16	All	9078
Supporter Guide Plate Dowel	3/8	All	9078
Supporter Guide Plate Dowel	1/2	All	9078
Supporter Guide Plate Dowel	5/8	All	9079
Swivel Assembly	5/16	All	9737A
Swivel Assembly	3/8	All	9538A
Swivel Assembly	1/2	All	9038A
Swivel Assembly	1/2	Rd Wire Only	9038M
Swivel Assembly	5/8	All	9838A
Swivel Assembly	5/8	Rd Wire Only	9838M
Wire Cutter	5/16	All	9745
Wire Cutter	3/8	All	9048
Wire Cutter	1/2	All	9048
Wire Cutter	5/8	All	9048
Wire Cutter Operating Slide	5/16	All	9749
Wire Cutter Operating Slide	3/8	All	9549
Wire Cutter Operating Slide	1/2	All	9049
Wire Cutter Operating Slide	5/8	All	9049

REGISTRATION

To better service your wire stitching needs, please take a moment to fill out and return this registration card.

Please take a moment to fill out the attached card and mail it to DeLuxe Stitcher Company, Inc. In addition, duplicate the information for your records to assist when making further inquiries.

CUSTOMER

Name : _____
(First) _____ (Middle Initial) _____ (Last) _____
Company : _____
Street Address : _____
City : _____ State/Province : _____ Zip : _____
Country : _____
Phone : _____ Fax : _____ E-mail : _____

PRODUCT

Machine(s) Purchased : _____
Serial Number(s) : _____
With Head(s) : _____
(Type/Quantity Purchased) _____
Serial Number(s) : _____
Head(s) Purchased : _____
Serial Number(s) : _____

DEALER

Date Received : _____
Dealer Name : _____
Dealer Street Address : _____
City : _____ State/Province : _____ Zip : _____
Country : _____
Dealer Phone : _____

Other Bindery Products Used : _____

PRODUCT

Machine(s) Purchased : _____
Serial Number(s) : _____
With Head(s) : _____
(Type/Quantity Purchased) _____
Serial Number(s) : _____
Head(s) Purchased : _____
Serial Number(s) : _____

DELUXE STITCHER GRAPHIC ARTS REPRESENTATIVE

Date Received : _____
Dealer Name : _____
Dealer Street Address : _____
City : _____ State/Province : _____ Zip : _____
Country : _____
Dealer Phone : _____

Would you like information sent to you about new products that would benefit your company? Yes No

Common Replacement Parts for 1/2" Crown

Below is a list of the most common wear/replacement parts for the 26/26D Stitcher Head. This guide should help you when ordering replacement parts. If the part you need is not listed below, please refer to the more detailed parts list on pages 38-40 in this manual.

Description	Item Number
Driver	9009-25
Driver Bar Assembly	9012A
Latch	9014
Grip	9015
Grip Spring	9019
Grip Spring Retaining Screw	9020
Grip Retaining Clip	9023
Grip Retaining Clip Screw	9024
Swivel Assembly	9038M
Wire Cutter	9048
Wire Cutter Oper. Slide Friction Plug	9050
Wire Cutter Slide Friction Spring	9051
Clincher Points-Thin	9083
Clincher Points-Thick	9083A
Tension Pawl	9098
Wire Straightener Roller	9103
Bender Bar Friction Plug	9112
Bender Bar Friction Spring	9113B
Wire Straightener Roll Clip	9124
Tension Pawl Spring	9134

PLACE
STAMP
HERE

DELUXE STITCHER
COMPANY INC.
6635 West Irving Park Road
Chicago, Illinois 60634-2410 U.S.A.
Attn: Customer Service

* You can purchase the 26DRPK which includes these and other common replacement parts

LIMITED WARRANTY

DeLuxe Stitcher Company warrants to the original retail purchaser that this product is free from defects in material and workmanship and agrees to repair or replace, at DeLuxe Stitcher's option, any defective product within 90 days from the date of purchase. This warranty is not transferable. It covers damage resulting only from defects in material or workmanship and does not cover conditions or malfunctions resulting from normal wear, neglect, abuse or accident.

This warranty is in lieu of all other express warranties. Any warranty of merchantability or fitness for a particular purpose is limited to the duration of this warranty. DeLuxe Stitcher shall not be liable for any incidental or consequential damages.

Some states do not allow limitations on how long an implied warranty lasts, or the exclusion or limitation of incidental or consequential damages, so the above limitations or exclusions may not apply to you. This warranty gives you specific legal rights and you may also have other rights which vary from state to state.

To obtain warranty service you must return the product, at your expense, together with proof of purchase to an authorized DeLuxe Stitcher Graphic Arts Dealer.

Always use genuine DeLuxe Stitcher parts. When ordering parts, please identify the part number, the part name, the wire size and crown size of your Stitcher.

DeLuxe Stitcher Company, Inc.
6635 West Irving Park Road
Chicago, Illinois 60634-2410
Phone: 773-777-6500 800-634-0810
Fax: 773-777-0156 800-417-9251
E-mail: info@deluxestitcher.com
Web Site: <http://www.deluxestitcher.com>

