



DELUXE STITCHER

COMPANY INC.

Machine Serial Number : _____

Head Serial Number : _____

Date Purchased : _____

Model M7 Stitchers

OPERATION AND MAINTENANCE MANUAL

M7-AST Stitcher.....115V and 60Hz

M7-BST Stitcher.....230V and 50Hz

M7-AST-19x21-1/2 Stitcher..115V and 60Hz

Before using this Stitcher, all operators must study this manual and follow the safety warnings and instructions. Keep these instructions with the M7 Stitcher for future reference. If you have any questions, contact your local DeLuxe Stitcher Graphic Arts Representative or Distributor.

WARNING!

Model M7 Stitchers

Operators and others in the work area should always wear safety glasses to prevent serious eye injury from fasteners and flying debris when loading, operating, or unloading this machine.

Do not operate this stitcher without all guards in place. The stitcher will not operate without the front guard closed properly. Do not modify the guards in any way. Always disconnect the power supply before removing any guards for servicing.

Never operate the machine with wire feeding through the head unless there is stock above the clinchers, otherwise serious damage may result.

Always turn power off when making adjustments. Always disconnect the power supply before any disassembly work.

Table of Contents

Introduction	4
Assembly	7
Belt Guard Removal and Assembly	8
Cycling Machine Manually	9
Operating Adjustments	9
Opening and Closing the Stitcher Head Door	10
Adjusting the Machine for Thickness of Work	11
Recommended Wire Sizes	12
Wire Threading	13
Wire Straightening	14
Adjustments and Settings.....	16
Adjusting the Left Leg	16
Adjusting Both Legs	17
Adjusting the Clincher Points	17
Troubleshooting	19
Maintenance	22
Lubrication and Cleaning.....	22
Ordering and Replacing Spare Parts	23
Disassembling the Head	24
Re-assembling the Head	32
Clutch-Brake Maintenance	34
Assembly Drawings	39
Part Number / Description Cross-Reference	55
Registration Card	59
Wear/ Replacement Parts	60
Warranty	61
Declaration of Conformity.....	62

Introduction

The DeLuxe Stitcher M7 Stitcher Machine is a single-head stitcher designed to accommodate both light and heavy-duty work, stitch both flat and saddle and is world renowned for its ability to reliably stitch any thickness of stock from 2 sheets to 7/8" (22.2mm).

The recommended wire sizes to be used on the M7 are: 24 to 28 gauge round wire and 20x24, 20x25 and 21x25 flat wire. These wire sizes can be used without changing any parts in the Stitcher head. However, for heavy flat work it is recommended that the special Flat Work Driver be substituted for the Standard Driver.

The M7 is easily adjusted from saddle work to flat work by tilting the 5 1/2" (14cm) x 26" (66cm) work table. An adjustable work guide and adjustable work stops are easily attached to the work table and provide for accurate registering of flat work for uniformly spacing the staples. In addition a work table extension is provided to accommodate larger sizes of work to be stitched. The M7 is the most versatile of all single-head machines.

The M7 is foot-switch operated and belt driven by a 1/2 HP motor, making possible operating speeds up to 125 stitches per minute. The motor is mounted on an adjustable bracket which can be raised or lowered to adjust driving belt tension. The machine driving mechanism is thoroughly shielded, preventing the possibility of personal injury.

The M7 has a 14" (35.6cm) throat depth for both flat and saddle stitching. The work table is approximately 34" (86.4cm) above the floor and there is approximately 1/8" (3mm) clearance between the top of the work to be stitched and the protective guarding around the stitcher head.

The M7 weighs 340 lbs. (154.5 kgs) net and the shipping weight is approximately 410 lbs. (186.4 kgs). With the table installed, the M7 requires about 31" (78.8cm) x 35" (88.9cm) of floor space.

Because of the length of the work table, the M7 must be secured to the floor to meet CE stability requirements. Sound level readings at the normal operator position are approximately 70 dB.

Specifications

Weight

Shipping Weight	440 lbs (200 kg)
M7 Stitcher Head	26 lbs. (11.8 kgs)
Wire Spool	5 lbs. (2.3 kgs) or 10lbs. (2.6 kgs) optional
Foot Switch	4.5 lbs. (2.0 kgs)
Table	8 lbs. (3.6 kgs)

Physical Dimensions

Height	65.0" (165.1 cm)
Width	
With Tables	26" (66.0 cm)
Without Tables	16" (40.6 cm)
Depth	29" (73.7 cm)

Stitching Capacity Two Sheets to 7/8" (22.2 mm)
..... at 20# paper stock (75 grams/inch²)

Wire Types 24-28 Round and 20x24, 20x25
..... and 21 x25 Flat
..... 19x21-1/2 Flat and 21-23 Round
..... with optional parts

Throat Depth

Flat or Saddle 14" (35.6 cm)

Side Stops 8-25" (20.3 cm-63.5 cm)

Power Requirements

M7-AST	115VAC 60 Hz
M7-BST	230VAC 50 Hz

Minimum Recommended Circuit Capacity

M7-AST	9.2 A
M7-BST	4.6 A

Installation

Pre-Inspection

Carefully inspect the condition of the shipping container before unpacking your M7 Stitcher. If the container is broken, damaged or has been tipped over and there is evidence that the machine may be damaged, immediately notify the carrier who delivered the machine and the DeLuxe Stitcher Graphic Arts Representative from whom the M7 was purchased.

Inspection

As you carefully unpack the machine, check to make sure all components were delivered and are in good working order. Refer to **figure 1** in this manual for reference to the following pieces:

- M7 Manual
- Driver Release Pin (5160)
- Work Stops (7423) and Screws (425)
- Work Guide (M7201) and two Screws (63)
- Complete Table Assembly (7656A) with Work Table Extension (7056) and two Thumb Screws (425)
- Wire Spool Bracket (G30120), Washers (PW14) and Screws (UA3806.16)
- Wire Guide Spring (15150LA)
- Wire Straightener Assembly (M7321A) and Screw (UA6816.2)
- Thumb Screw (P2731), Set Collar (7691), Tension Spring (7690), Plastic Washer (M11009), Wire Spool, Spool Stud (7693), Flat Washer (PG10271), Large Spool Stud Washer (2245), Washer 3/8 (PW38) and Hex Nut 3/8-16 (HN3816)
- Stitch Samples

Pre-Installation

Please take a few moments to fill out the registration card located on page 67 prior to beginning installation.

Always disconnect the power supply before making any adjustments or servicing the stitcher.

 **WARNING**

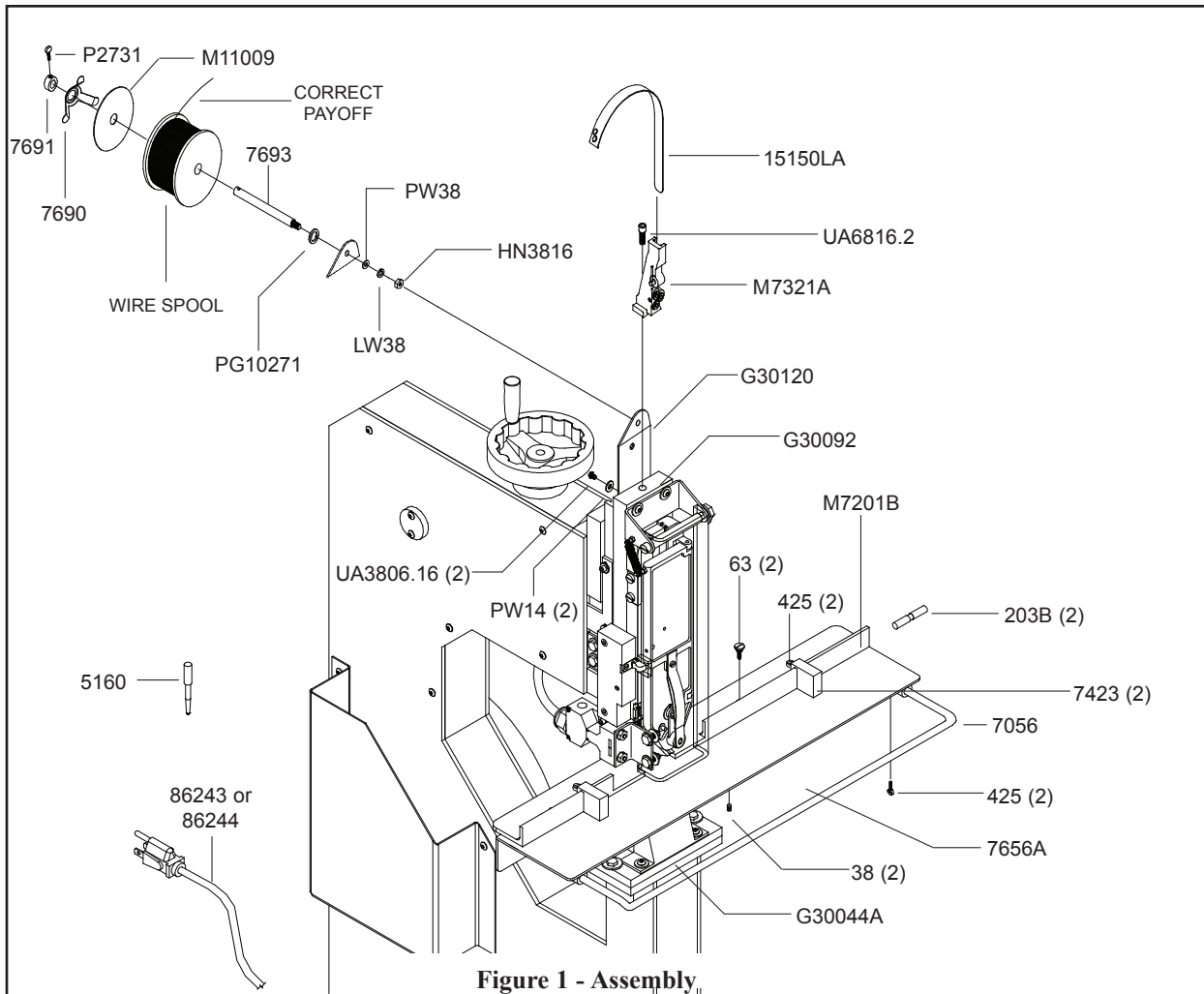

Figure 1 - Assembly₁₁

Assembly (Figure 1)

Some assembly is required upon delivery of the M7 Stitcher. You will need a flat screwdriver, 5/32" and 3/8 hex head wrenches and a 9/16 open end wrench. Line up the hole in the Wire Straightener Assembly (M7321A) with the screw hole in the Head Mounting Plate (G30092). Secure the assembly with the Socket Head Cap Screw (UA6816.2). Assemble the Wire Spool Bracket (G30120) to the back of the Head Mounting Plate with two (2) Screws (UA3806.16) inserted through two (2) 1/4 Washers (PW14). Remove the Flat Washer (PW38), the Lock Washer (LW38) and the Plain Nut (HN3816) from the Spool Stud (7693) and insert it into the back of the Wire Spool Bracket. Secure the Spool Stud by replacing the Washers and the Nut. Loosen the Thumb Screw (P2731) in the Set Collar (7691) and remove it and the Tension Spring (7690) from the Spool Stud. Slide the Wire Spool over the Spool Stud, making sure that the Flat Washer (PG10271) and the Large Spool Stud Washer (2245) are between the Spool and the Wire Spool Bracket. Also verify that the wire payoff is identical to the payoff in Figure 1. Improper wire payoff will result in poor stitching. Slip the Plastic Washer (M11009) over the Spool Stud and replace the Tension Spring and Set Collar. Apply slight pressure on the Set Collar, pre-loading the Tension Spring, then tighten the Thumb Screw in the Set Collar until secured in position. A properly set Tension Spring will cause the Wire Guide Spring (15150LA) to flex but not actually hit the wire spool.

Insert the Wire Guide Spring (15150LA) into the top of the Wire Straightener Assembly. Loosen the two (2) Set Screws (38) and remove the two (2) Work Table Swivel Pins (203B) from the Clincher Mount Assembly (G30044A). Line up the holes on the underside of the Complete Table Assembly (7656A) with those in the Clincher Mount Assembly and replace the Swivel Pins. Secure the Swivel Pins by tightening the Set Screws in the Table Assembly. With the Table Assembly in the flat position, mount the Work Guide (M7201B) with two (2) Thumb Screws (63). Slide the two (2) Work Stops (7423) onto the Work Guide and tighten the Thumb Screws (425) to secure in the desired position.

Note: Do not allow the Work Guide to interfere with the stitcher head as this will cause damage to both.

Electrical power is provided through the attached Power Cord (86243 or 86244) and should be connected to an appropriate supply outlet but do not power on the machine until all safety checks have been made. The machine has to be turned over manually to verify that the stitcher head is operating freely before the M7 can be operated under power.

Note: Be sure to level the machine and secure it to the floor before use.

Belt Guard Removal and Assembly (Figure 2)

The plastic Belt Guard (7676) must be removed before the M7 can be turned over manually. To remove the Belt Guard, remove the Retaining Screw (G30163) from the top of the Guard (on International models only). Press on one side tab while prying out the locking face, at the top of the Guard. Next, pull down slightly on the top of the Guard to release the bottom tab. The Guard will now be free to lift off from around the Belt Guard (7675).

To reassemble, interlock the bottom tab and pull up slightly on the Guard to interlock the side tab, then squeeze the two halves of the Guard together to lock the remaining tab. Reassemble the retaining screw at the top of the Guard (on International models only).

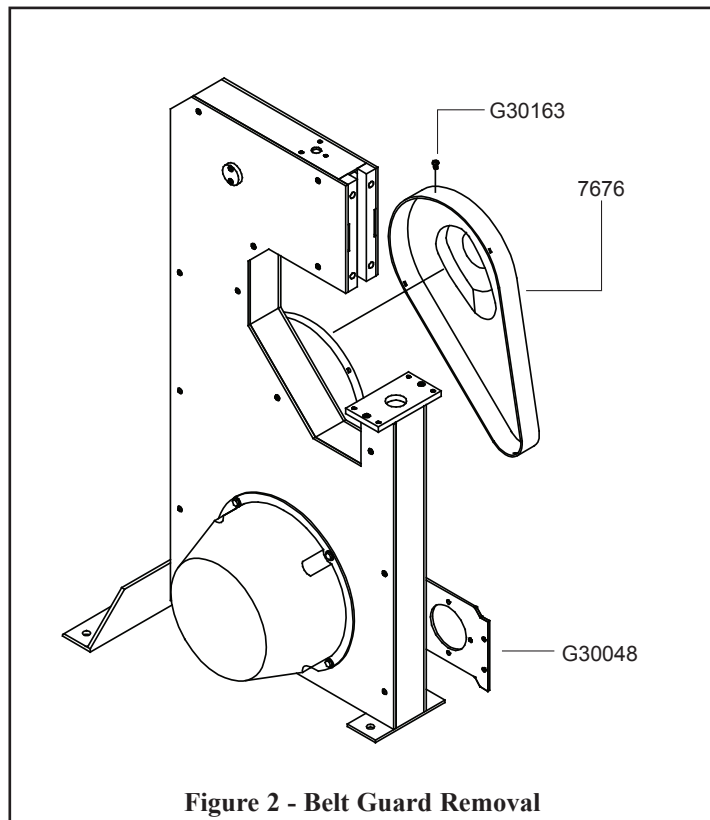

Figure 2 - Belt Guard Removal

Always disconnect the power supply before making any adjustments or servicing the stitcher.

WARNING

Cycling Machine Manually / Adjusting the V-Belt (Figure 3)

To turn the machine manually, it is first necessary to disconnect the power and remove the Belt Guard (7676), see the section “Belt Guard Removal” on page 8. Locate the Actuator Assembly (850992) on the Wrap Spring Clutch (850677 or 850678) and push the Actuator so that it pivots away from the Control Collar Cam (850888), releasing the Brake Hub (850892). The machine will rotate one revolution when the Drive Pulley (7678B) is turned manually in the direction of the arrow on the pulley.

To tighten the V-Belt (850730B) first loosen, but do not remove, the four (4) Hex Nuts (HN3816) on the Motor Mounting Plate (G30048). Use a screw driver as a lever between the stitcher’s frame and the Mounting Plate to move the Plate down slightly. Pressing on the Pulley (11399A or 850732) may knock it out of position. Tighten the four (4) Hex Nuts again when the V-Belt is taut. The V-Belt should first be tightened after two to three weeks of use and then periodically after that.

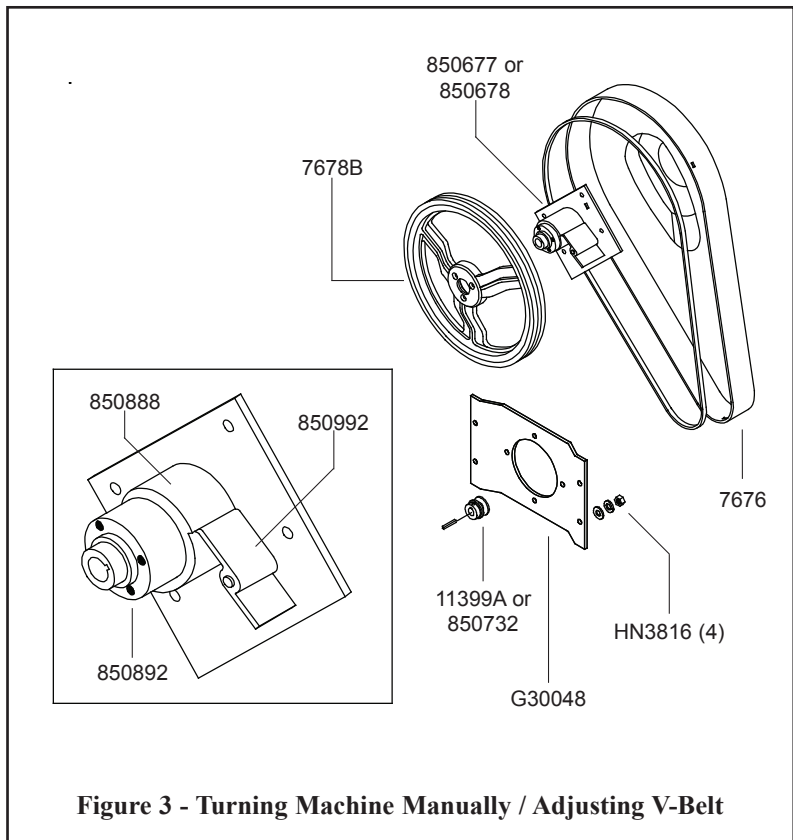

Operating Adjustments

The quality and quantity of work that can be stitched on the M7 is dependent upon the operator making the necessary operating adjustments as accurately as possible. The following information and instructions are provided so that the operator will clearly understand how to make the required operating adjustments.

The following adjustments, if followed accurately, will assure the optimal performance of the M7 Stitching Machine.

Always disconnect the power supply before making any adjustments or servicing the stitcher.

⚠ WARNING

Opening and Closing the Stitcher Door (Figure 4)

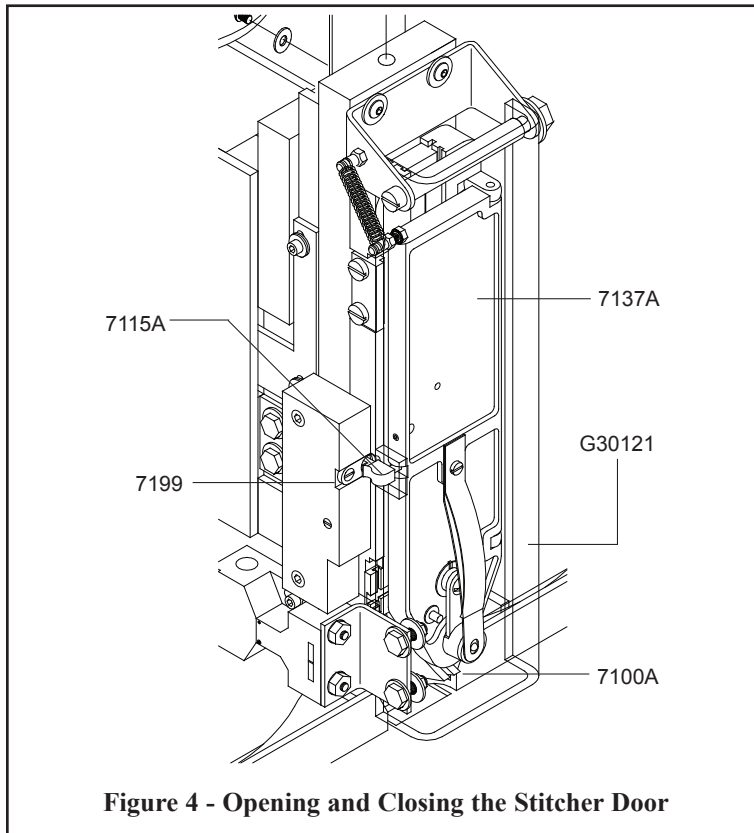

Figure 4 - Opening and Closing the Stitcher Door

To open the stitcher head Door Assembly (7137A), raise the pivoting Head Guard (G30121) up clear of the Door Assembly. Compress the Door Latch (7115A), releasing it from the Door Latch Catch (7199) and swing the Door to its open position. **The M7 cannot be cycled without all of its guards in place**, so if it is necessary to operate the stitcher with the stitcher Door Assembly open, lower the Head Guard back into place with the Door fully open. The machine can then be cycled under power.

To close the Door make sure that the stitcher is at the top of its cycle and the Supporter Assembly (7100A) is at its

forward position. Push the Supporter back to its retracted position and hold it there with one hand while closing the door. The Door is fully closed when the Door Latch engages with the Door Latch Catch. The Head Guard can be lowered into its operating position at this point

Note: Make sure the Door is secure before operating under power to avoid damage to the Head.

Do not slam door shut, or attempt to force door shut while cycling machine or with machine positioned at bottom of stroke. Failure to comply with this may result in damage to the stitcher head.

⚠ CAUTION

Adjusting for Thickness of Work (Figure 5)

Unlock the Hand Wheel (G30128) by turning the Adjuster Crank Lock (G30158) on the Adjuster Crank Housing (G30099) counter-clockwise. Turn the Hand Wheel clockwise until the Adjuster Spool (G30119) is raised sufficiently to allow a sample of work to be inserted between it and the lower Adjuster Stop (G30103). The thickness gauge is located on the right-hand side of the machine if you are looking from the front of the stitcher. With the work held flat in a horizontal position, turn the Hand Wheel counter-clockwise until the work is firmly clamped between the Adjuster Spool and the lower Adjuster Stop. Turn the Hand Wheel back clockwise just enough to allow the work to be withdrawn from the Adjuster Spool, then return the Hand Wheel to the setting at which the work was clamped.

Anytime the thickness of work changes, a sample should be tested in the M7 so no serious damage is caused to the machine. If the machine is operated on work thicker than it is set to handle, damage will result and the stitcher machine will not operate properly.

Note: When adjusting for more than a slight decrease of work thickness, trip the M7 occasionally while turning the Hand Wheel to protect the Wire Feed Adjusting Pinion (7114)

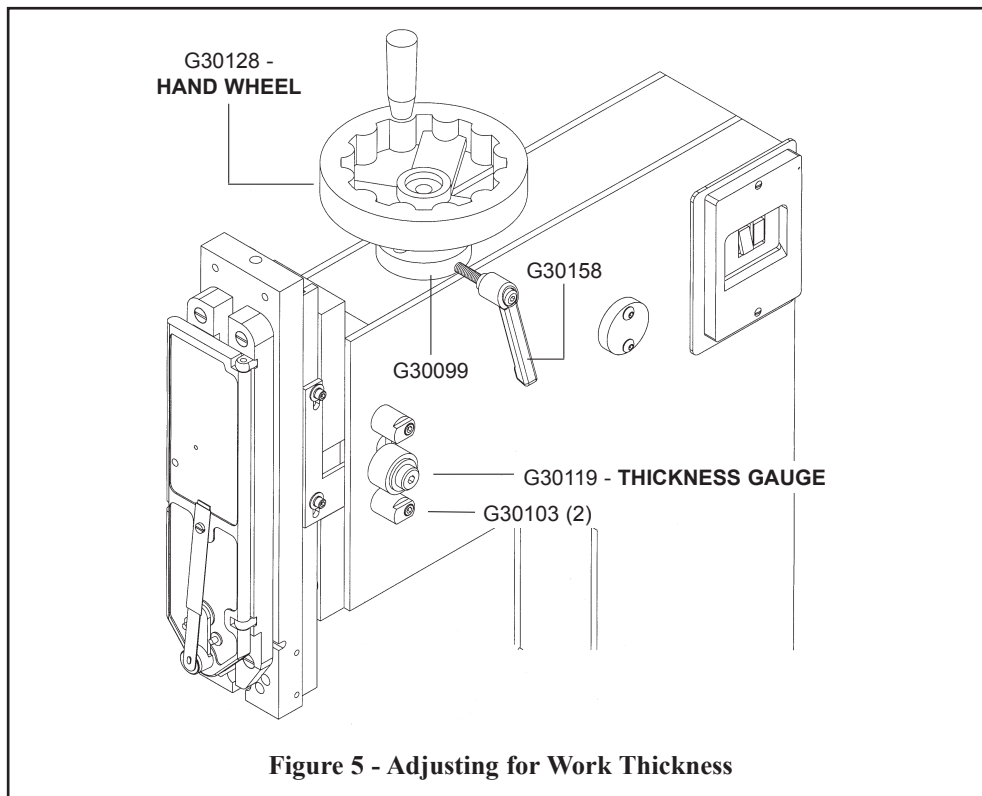

If the machine is operated on work thicker than it is set to handle, damage will result.

WARNING

Recommended Wire Sizes (Figure 6)

The wire sizes to be used on the M7 are listed below. Though all of the listed wires can be run without changing any parts in the Head, it is recommended that the **7089F Driver** be substituted for the 7089E Driver when doing **heavy flat work**. For instructions on how to change the Driver, see page 28.

Two types of Clincher Points are provided with the M7. When running round wire, use the Clincher Points with part number **7257B**. When running flat wire, use the Clincher Points with part number **7024B**.

When stitching stock over 20# it is recommended that a high tensile wire be used, which is available in 21x25, 20x24 and 19x21-1/2 flat wire sizes. The high tensile wire may cause increased wear on certain parts.

For any stock over 33# or coated stock it is recommended that 19x21-1/2 flat wire be used. In order for the M7 Stitcher to accommodate this size wire, the following parts must be exchanged: Bender Bar Assembly (7086BA), Driver (7089G), Wire Guide Assembly (7111BA), Wire Holder Slide (7130B), Wire Straightener Rollers (7277B) and the Clincher Points (7024C). See pages 57 and 58 for an exploded view of the parts necessary for the 19x21-1/2 flat wire conversion.



Wire Gauge	Type of Work	20# Stock
28 Round	Light Flat or Saddle	2-5 Sheets
27 Round	Light Flat or Saddle	2-5 Sheets
26 Round	Light Flat or Saddle	2-10 Sheets
25 Round	Medium Flat or Saddle	2-40 Sheets
24 Round	Medium Flat or Saddle	2-60 Sheets
Install 7089F Driver / 7024B Clincher Points for:		
21 x 25 Flat	Heavy Flat Only	Over 50 Sheets 1/4"- 3/8"
20 x 25 Flat	Heavy Flat Only	Over 50 Sheets 1/4"- 5/8"
20 x 24 Flat	Heavy Flat Only	Over 50 Sheets 1/4"- 7/8"
19 x 21 1/2 Flat	Heavy Flat Only	1/2"- 7/8" and Heavy Paper

Figure 6 - Recommended Wire Sizes

Always disconnect the power supply before making any adjustments or servicing the stitcher.

WARNING

Wire Threading (Figure 7)

Open the stitcher head Door Assembly (7137A) as described on page 10. Pass the wire from the Wire Spool over the Wire Guide Spring (15150LA) and between the Wire Guide Spring Studs (2110B).

Continue threading the wire between the two (2) sets of Wire Straightener Rollers (7277) on the Wire Straightener Assembly (M7321A). Pass the wire under the Wire Clip (7212) on the Wire Feed Slide Assembly (7112A), in the groove of the Wire Grip Holder (7133A), behind the Wire Retainer (7167) on the Wire Guide Assembly (7111A), through the groove of the Wire Cutter Holder (7103A), continuing until it runs between the arms of the Supporter Assembly (7100A). It is not essential that the wire be between the Fixed and Moving Grip during threading as it will slip during the first stroke.

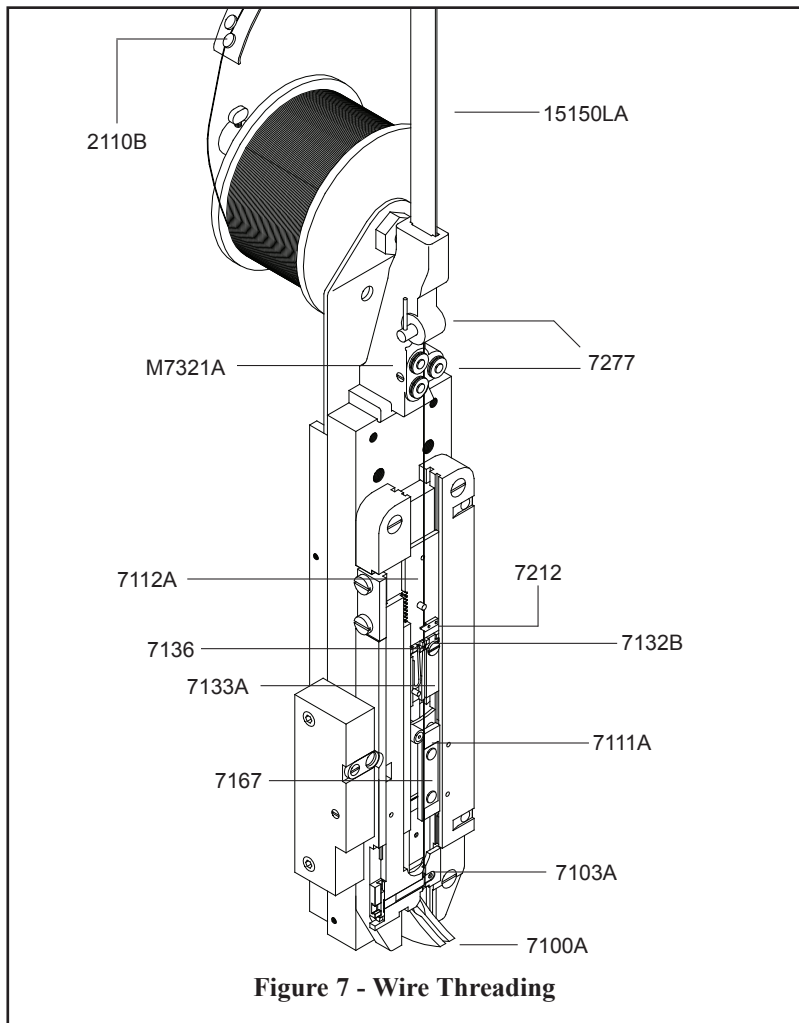

Figure 7 - Wire Threading

Turn the machine over manually until the wire falls into place between the Movable (7136) and Fixed Wire Grips (7132B). Continue to turn the machine over manually a few more revolutions to ensure that the wire is feeding freely and is being cut by the Cutters. Make sure that the machine is at the top of its cycle and close the stitcher head Door.

It is now safe to power on the M7 stitcher.

To avoid serious damage do not feed wire through the head under power without stock in position.

WARNING

Wire Straightening (Figure 8)

In order to insure continuous operation of the Stitcher, it is important that the wire is fed into the Swivel Assembly (7138A) in as close to a straight-vertical line as possible. To check this condition and make the necessary adjustments if needed, proceed as follows:

Raise the Head Guard (G30121) clear of the Door Assembly (7137A), disengage the Swivel Spring (7140) from the Swivel Assembly and remove the Swivel Assembly from the Swivel Bushing Assembly (7139A).

Close the Door Assembly and bring the Head Guard back into position. Trip the machine several times and observe the wire as it is feeding by looking directly through the Swivel Bushing.

If the wire is feeding to the left or to the right, turn the Spirol Pin (UB3912.2), controlling the set of Wire Straightener Rollers (7277) on the front of the lower Wire Straightener Assembly (M7321A),

clockwise or counter-clockwise, as required, until the wire feed straightens. Allow enough Wire to be fed through the Head so that an accurate assessment can be made.

Once the wire is feeding correctly to the left and right, observe the wire as it feeds from the side of the stitcher head. If the wire is feeding to the front or the back, turn the wire straightener Spirol Pin (UB3912.2), controlling the set of Wire Straightener Rollers on the side of the Wire Straightener

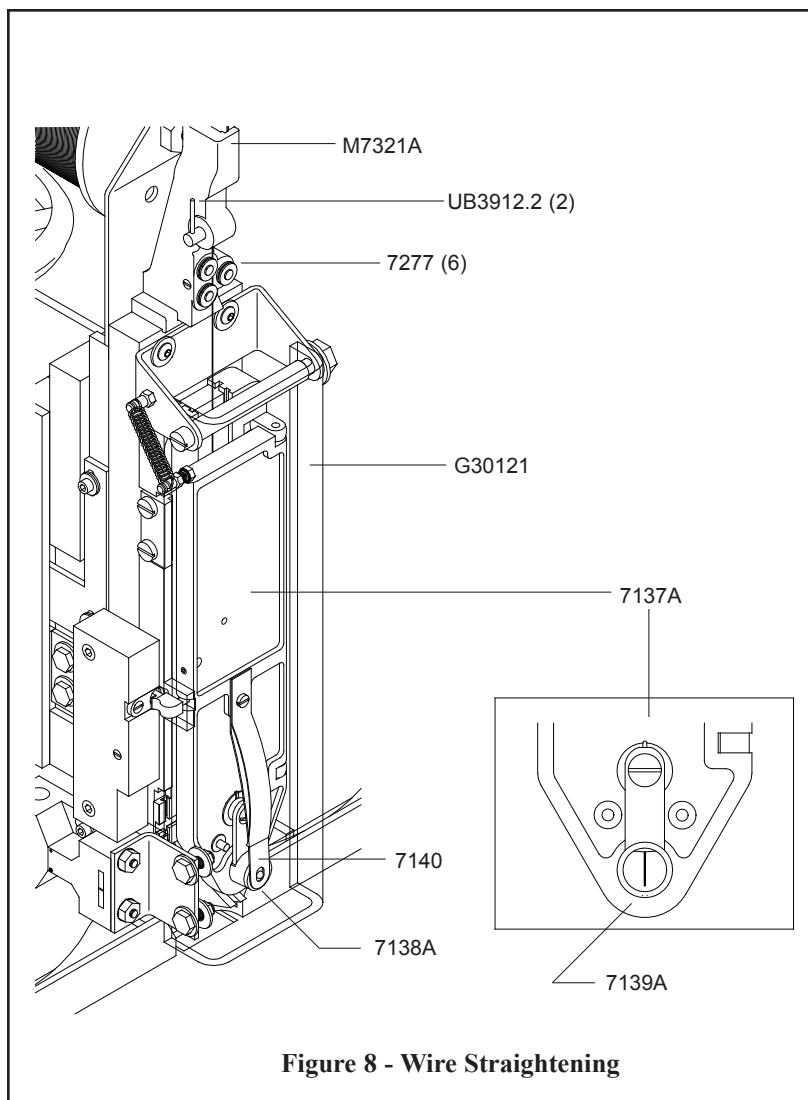

Figure 8 - Wire Straightening

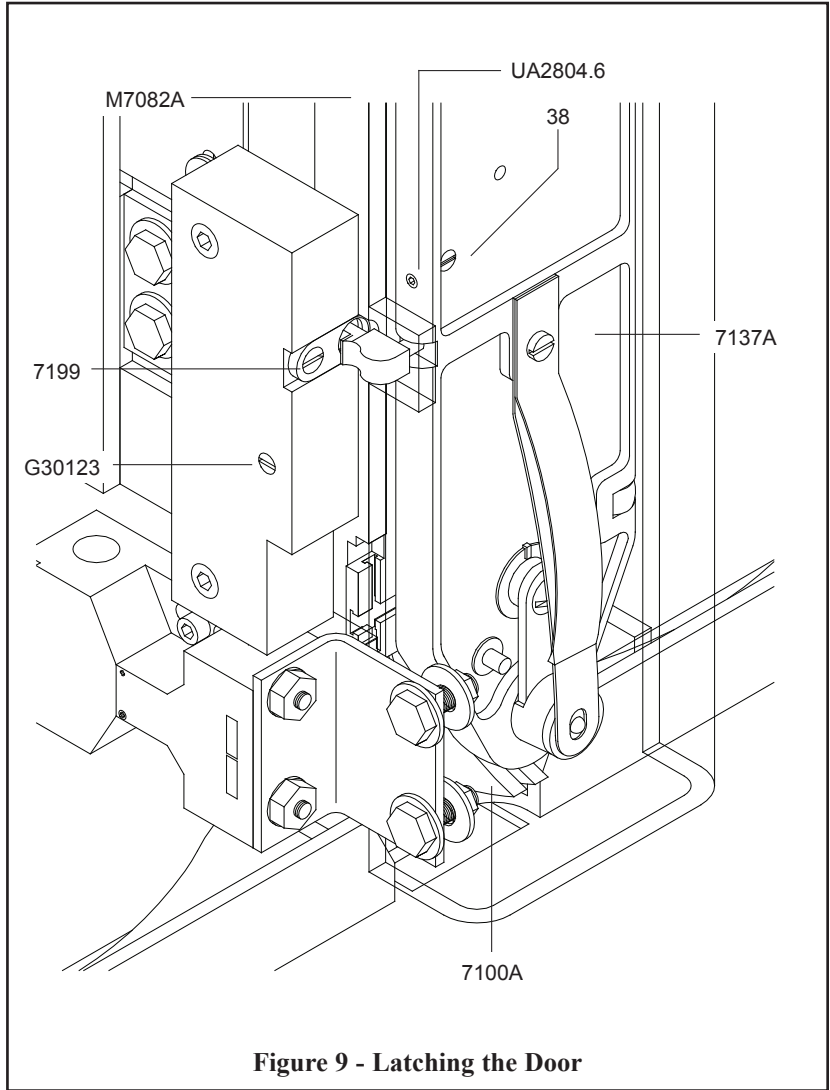

Figure 9 - Latching the Door

Assembly, until the wire feed straightens. Allow enough wire to feed through the head to reflect the adjustments made. The Wire Guide Spring (15150LA) also affects the front to back wire straightness and can be adjusted to compensate for the feeding. When wire straightness has been achieved, make sure that the machine is at the top of its cycle and replace the Swivel Assembly and the Swivel Spring. Compress the Supporter Assembly (7100A) and close the Door Assembly until it is securely latched.

If the Door Assembly (7137A) is not properly balanced it rattles. To correct this, loosen the Set Screw (UA.2804.6) on the side of the Door and adjust the depth setting of the Screw (38) in the Door Assembly. Refer to **Figure 9** for reference to accurately balance the Door against the Face Plate Assemblies (M7083A and M7082A). When the Door no longer rattles, tight-

en the Set Screw on the side of the Door and latch the Door shut. If the Door Assembly is difficult to shut after making this adjustment, back the Screw (38) off slightly to ensure proper closure.

Test the machine one last time to make sure any adjustments made are correct and make sure that the Door Assembly stays closed during the machine's revolutions. If not, check both the position of the Door Latch Catch (7199) in the Face Plate Hinge Mount (G30123) as well as the depth setting of the Screw in the Door Assembly itself.

Adjustments and Settings

Adjusting the Left Leg (Figure 10)

If the Wire for the staple is cut off center (one leg is longer than the other), the left leg of the staple can be adjusted as follows:

First tap the Wire Grip Holder Assembly (7133A) towards the Wire Guide Assembly (7111A) out of the way. Loosen the two Wire Feed Adjuster Rack Screws (7219) slightly. To **shorten the left leg** of the staple, move the Wire Feed Adjuster Rack (7113) up slightly and tighten the Screws. If more adjustment is needed, loosen the Wire Feed Adjusting Rack Screws again and disengage the teeth of the Adjusting Rack from those of the Wire Feed Adjusting Pinion (7114) by pulling the Rack away from the Pinion. The Feed Slide will now be free to move up or down. Move the Wire Feed Slide (7112A) down to shorten the left leg, engage the teeth of both the Wire Feed Adjusting Pinion and the Wire Feed Slide and tighten the Adjuster Rack Screws. Trip the machine to allow enough wire to feed through the head to reflect the adjustment and check the stitches again. Repeat the steps above as needed until the staple legs are equal in length and the centered in the clinch.

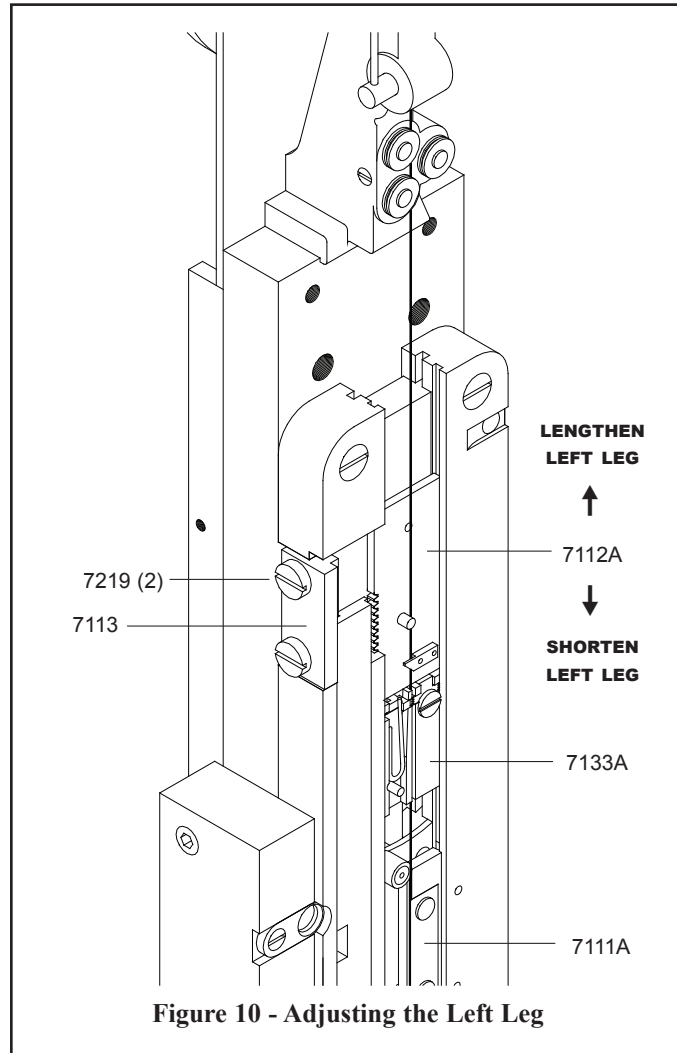

Figure 10 - Adjusting the Left Leg

The same is true to **lengthen the left leg** of the staple. Loosen the Adjuster Rack Screws, disengage the teeth and move the Adjuster Rack down slightly and re-tighten the Screws. If more adjustment is needed, loosen the Wire Feed Adjusting Rack Screws again and disengage the teeth of both the Wire Feed Adjusting Pinion and the Wire Feed Slide. Move the Wire Feed Slide up to lengthen the left leg, engage the teeth of both the Wire Feed Adjusting Pinion and the Wire Feed Slide and tighten the Adjuster Rack Screws. Trip the machine to allow enough wire to feed through the head to reflect the adjustment and check the stitches again. Repeat the steps above as needed until the staple legs are equal in length and the centered in the clinch.

Adjusting Both Legs (Figure 11)

If the staple legs are centered but are too long or too short, adjust the amount of wire feed as follows: First tap the Wire Grip Holder Assembly (7133A) out of the way. Loosen (do not remove) the two (2) Screws (7219) on the Upper Adjuster Rack, then loosen (do not remove) the two (2) Wire Feed Adjusting Rack Screws (UA4108.1) on the Lower Adjuster Rack (G30090) to allow the Rack to be moved up or down. If longer staple legs are required, move the Rack down slightly. If shorter staple legs are required, move the Rack up slightly. Tighten the Adjustment Screws and trip the machine to allow enough wire to feed through the head to reflect the adjustment. Check the stitches again. Repeat the steps above as needed until the staple legs are the correct length for the work being stitched.

Be careful not to force the Wire Feed Adjusting Pinion (7114) in between the lower Adjuster Rack and the upper Adjuster Rack (G30091), behind the Face Plate Latch Mount (G30123) as it could strip the teeth off the Pinion.

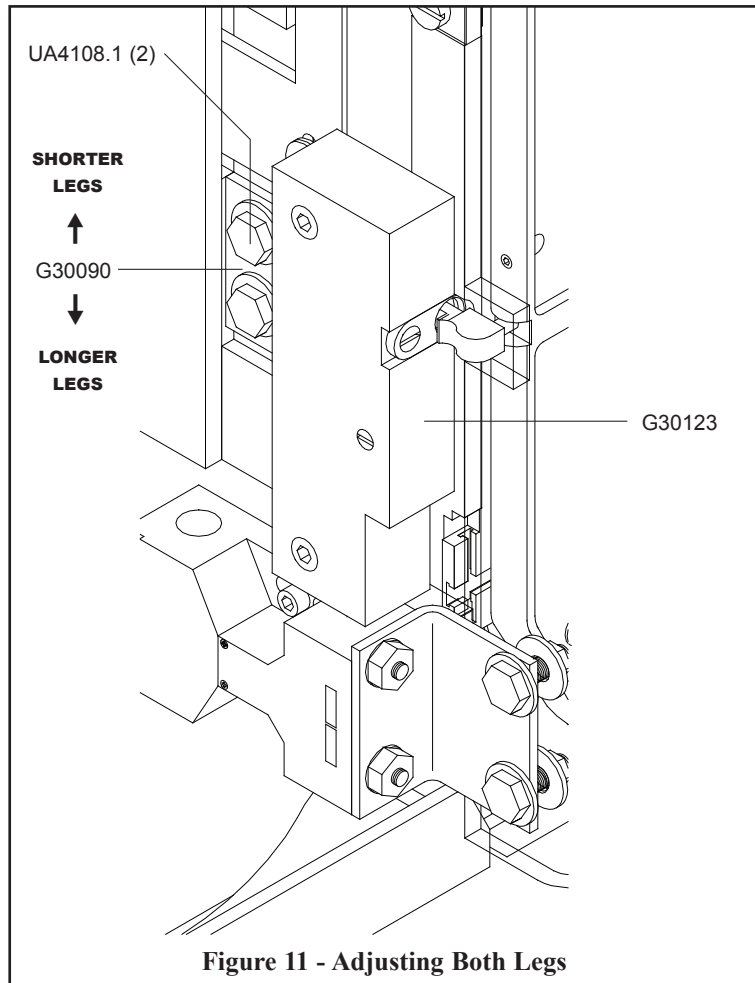

Note: The upper Adjuster Rack should be forced flush with the back of the stitcher Frame to ensure uniform movement after tightening

Always disconnect the power supply before making any adjustments or servicing the stitcher.

WARNING

Adjusting the Clinchers (Figure 12)

If the staples are not clinching properly the Clincher Points (7257B, 7024B) will need to be adjusted within the Clincher Plate (7253A). To check this, cycle the machine manually and stop the machine at the point of clincher activation. If the Points are positioned too high or too low, refer to the instructions which follow and **Figure 12** for an explanation. Loosen and remove the two (2) Screws (UA3806.16)

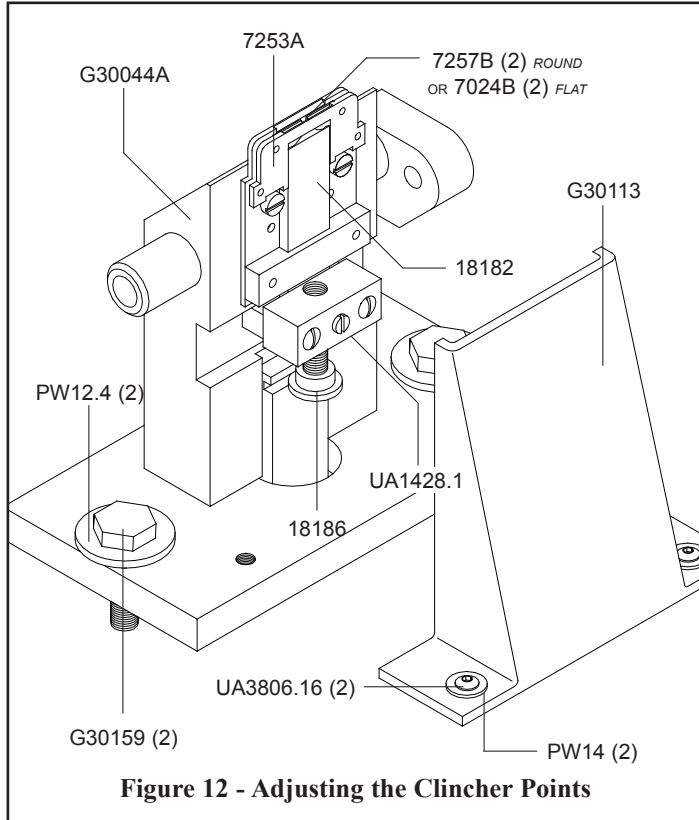

Figure 12 - Adjusting the Clincher Points

and the two (2) Washers (PW14) securing the Clincher Guard (G30113) to the Clincher Mount Assembly (G30044A) and remove it. Loosen the Set Screw (UA1428.1) and rotate the Clincher Slide Adjustment Screw (18186), which raises or lowers the Clincher Slide (18182), adjusting the Clincher Points as needed. Tighten the Set Screw and replace the Clincher Guard with the two (2) Washers and two (2) Screws.

If the stitch clinches properly but the legs are angled away from its crown, the Clincher Plate (7253A) may not be aligned with the Driver (7089E or F). Refer to both **Figure 12** and **Figure 13** and the following instructions for directions on centering the Clincher

Points (7024B, 7257B).

Loosen the two (2) Screws (G30159) securing the Clincher Mount Assembly to the Frame Weldment (G30001A). With wire threaded through the machine and the compression set to 1/8" turn the machine over manually, but stop as the staple begins to exit the Bender Bar. Adjust the Clincher Mount Assembly, side to side, so that the Driver is centered above the Clincher Points and in line front to back, so that the legs of the staple line up with the Clincher Points. Re-check the side-to-side adjustment after completing the front-to-back adjustments and then tighten the two (2) Screws (PG10512) securing the clincher Head Guard to the Clincher Mount Assembly. After tightening, re-run this procedure to ensure proper alignment.

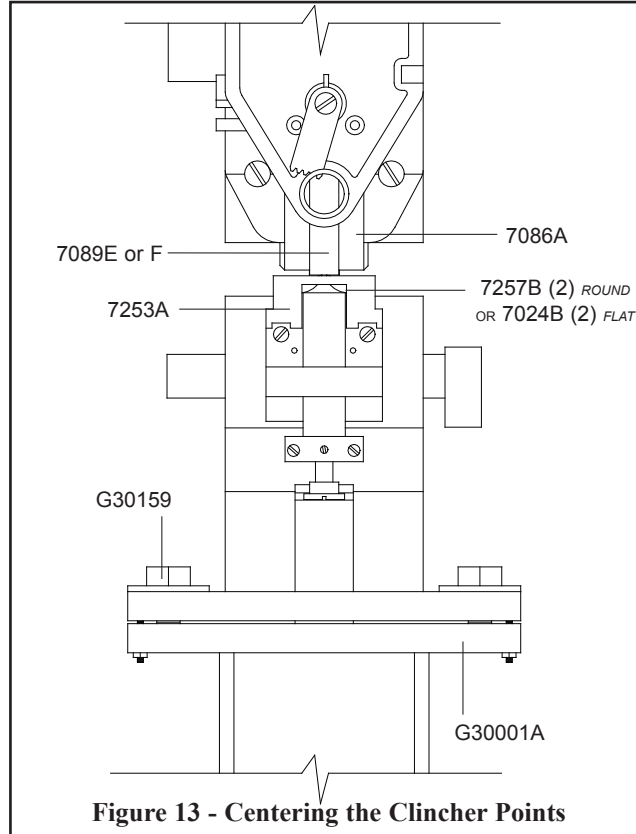

Figure 13 - Centering the Clincher Points

Troubleshooting (Figure 14)

The following is a brief list of problems and solutions which should cover the majority of situations encountered when stitching with the M7. The quality and quantity of work that can be produced with the M7 Stitcher is dependent upon the operator making all adjustments as accurately as possible and carefully maintaining the machine. The cause of staple imperfections usually can be traced to inaccurate settings or normal wear of moving parts. In the event of problems of this nature occurring, the operator can, by referring to the following troubleshooting chart, quickly locate the solutions.

PROBLEM: Stitch quality is poor.

SOLUTION:

1. Check the Wire Cutters (7102) for wear to see if they need to be reversed or replaced.
2. Check for straightness as the wire feeds through the Head.

PROBLEM: The machine will not complete a cycle, both under power and manually.

SOLUTION:

1. Make sure the compression setting is correct. If not turn the Hand Wheel (G30128) clockwise to raise the stitcher head.
2. The Supporter (7100A) may not be freely moving between the sides of the Bender Bar (7086A) which can be corrected by bending the arms of the Supporter Link (7100) slightly but most likely the Supporter will have to be replaced.
3. The Left (7095) or Right Wedge (7208) may not be seated completely. Remove the Face Plates and gently tap each of the Wedges in until flush with the edge of the Face Plates.

PROBLEM: The wire is being cut but dropped before it can be formed.

SOLUTION:

1. Check wire straightness.
2. If the problem continues, check to see if the inside corners of the Swivel Operating Sector (7146) are still intact and replace if necessary.
3. If there is play between the Sector and the Swivel Operating Lever (7142), replace the Sector.
4. The Swivel Operating Lever Spring (7226) may need to be replaced if not offering enough resistance.
5. Make sure that the wire is feeding straight from the Wire Spool, if not adjust the Wire Straightener Rollers (7277).
6. Check for a damaged Swivel Hook (7232) and/or Swivel Hook Spring (7234).

PROBLEM: There is inconsistent wire draw shown by varying lengths in the staple legs.

SOLUTION:

1. Check to see if the wire is hitting the Swivel Assembly (7138A) and adjust for straightness.
2. Premature wearing could be caused by restricted movement of the Wire Grip Holder (7133A) between the Face Plates which in turn causes inconsistent draw.

3. The Wire Cutter Slide (M7107A) may also be too tight in the Left Face Plate (M7082A) causing inconsistent cutting. (The Head should be disassembled, cleaned and lubricated).
4. Check to see if the Wire Feed Shoes (7154) are worn and need to be replaced.
5. The wire is not properly fed through the Wire Guide Spring and the Straightener Rollers; correct.
6. Check to see if the Straightener Rollers (7277) are crimping the wire and adjust.
7. The Moveable (7136) and/or Stationary Grip (7132B) may be worn and have to be replaced.
8. A weak Wire Grip Spring (7134B) will not position the Moveable Wire Grip correctly; replace.
9. The Grip Operating Lever (7176) and/or the Grip Operating Lever Slide (7178) may be bent or broken. If this is the case, these parts should be replaced.

PROBLEM: The wire is being bent, not cut or it is jamming within the head.

SOLUTION:

1. First check to see that the Wire Cutters (7102) do not have to be reversed or replaced.
2. Make sure the Wire Cutter Retainer (7109) is secure within the Wire Cutter Holder (7103A), if not make a notch in the Wire Cutter Holder above the Retainer with a screwdriver. This will secure the upper Wire Cutter (7102) in position.

PROBLEM: The wire is being pulled back out of the Wire Cutter Holder (7103A) after each stitch.

SOLUTION:

1. The Grip Operating Lever (7176) is broken or damaged and needs to be replaced.
2. The Wire Feed Shoes (7154) are worn causing both of the grips to not react properly and need to be replaced.

PROBLEM: Wire is accumulating in the Swivel Assembly or stitches are only partially formed.

SOLUTION:

1. If the Swivel Assembly (7138A) sits too far out from the Bender Bar the stitch will not be formed or only partially formed, adjust the Set Screw (38) in the Door Assembly (7137A).
2. If the Driver Bar Latch (7094) is not activated properly, the Driver (7089E or 7089F) will move the Swivel Assembly out of the way before the stitch is formed. Bring the stitcher head down for large scale adjustment or tap the Left Driver Bar Wedge (7095) in slightly for fine adjustment. See pages 11 and 29.

When stitches are defective, the operator can compare the staple produced with the illustrations in the chart. By carefully following the information given in the chart, the operator can quickly resolve the problem, keeping downtime to a minimum.









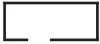

	<p>PROBLEM: Left Leg Short SOLUTION: Lengthen the left leg by moving the Adjusting Rack (7113) down. For more adjustment, move the Wire Feed Slide (7112A) up. (See page 16)</p>
	<p>PROBLEM: Left Leg Long SOLUTION: Shorten the left leg by moving the Adjusting Rack (7113) up. For more adjustment move the Wire Feed Slide (7112A) down. (See page 16)</p>
	<p>PROBLEM: Corner Buckled SOLUTION: Check the Driver (7089E or 7089F) for a chipped corner and rotate or replace it if needed. (See page 28)</p>
	<p>PROBLEM: Leg(s) Buckled SOLUTION: Check the Wire Cutters (7102) for wear and rotate or replace if needed. (See page 26) If the ends of an unformed piece of wire are not smooth, the Cutters are worn.</p>
	<p>PROBLEM: Crown Buckled SOLUTION: Check Supporter Spring (7240) tension. Check for correct wire size being used. Check for correct work thickness setting.</p>
	<p>PROBLEM: Partially Formed Stitches SOLUTION: Replace worn Driver Bar Wedges (7208 and 7095) and/or the Driver Bar Latch (7094).</p>
	<p>PROBLEM: Stitch in Pieces SOLUTION: Clean and replace Swivel (7138A). (See page 23) If problem persists, file the forming corner of the Swivel slightly with a honing stone.</p>
	<p>PROBLEM: Corners of the Crown are Rounded SOLUTION: Replace the worn Swivel (7138A).</p>
	<p>PROBLEM: Loose Clinch SOLUTION: 1. Wrong thickness setting. (See page 11) 2. Reset the Clincher Points height (7024B). (See page 29) 3. Replace the worn Clincher Points. 4. Replace the Worn Clincher Slide (18182).</p>
	<p>PROBLEM: Legs are Spread or Contracted SOLUTION: Readjust the Wire Straightener Eccentrics to improve straightness. (See page 14) Check the Wire Cutters for wear and rotate or replace. (See page 26) Check the Bender Bar (7086A) for wear in the grooves and replace if necessary.</p>

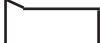
Figure 14 - Troubleshooting

Maintenance

Lubrication (Figures 15 and 16)

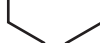
Your M7 Machine has been fully lubricated at the factory, but regular preventative maintenance will result in superior performance and a longer life of the machine. Machines that are in constant use should be lubricated daily whereas machines that are only operated periodically should be lubricated just prior to use. Usually only a drop of oil is required at each lubrication point in the stitcher head. Care must be taken that those parts of the machine that contact work remain free from oil.

Lubricate regularly instead of excessively.

Excessive oiling will result in work becoming oil-spotted. After lubricating the machine, wipe off any excess oil. Use one drop of any standard S.A.E #10 oil in the following lubrication points:

- the oil hole in the Wire Feed Slide (7112A)
- the oil hole in the Wire Cutter Holder (7103A)
- the oil hole in the Swivel Operating Cam Roller Stud on the Driver Bar Assembly (7091A)
- the oil hole in the Door Assembly (7137A) leading to the Swivel Operating Lever (7142)
- the opening in the Swivel Bushing (7139A)
- the rails of both the Left Face Plate Assembly (M7082A) and the Right Face Plate Assembly (M7083A)
- between the Moveable Wire Grip (7136) and the Fixed Wire Grip (7132B)
- on the Rod in the Driver Bar Assembly (7091A) and on either side of the Driver (7089E) and on the Driver Bar Latch (7094)
- the top of each Face Plate

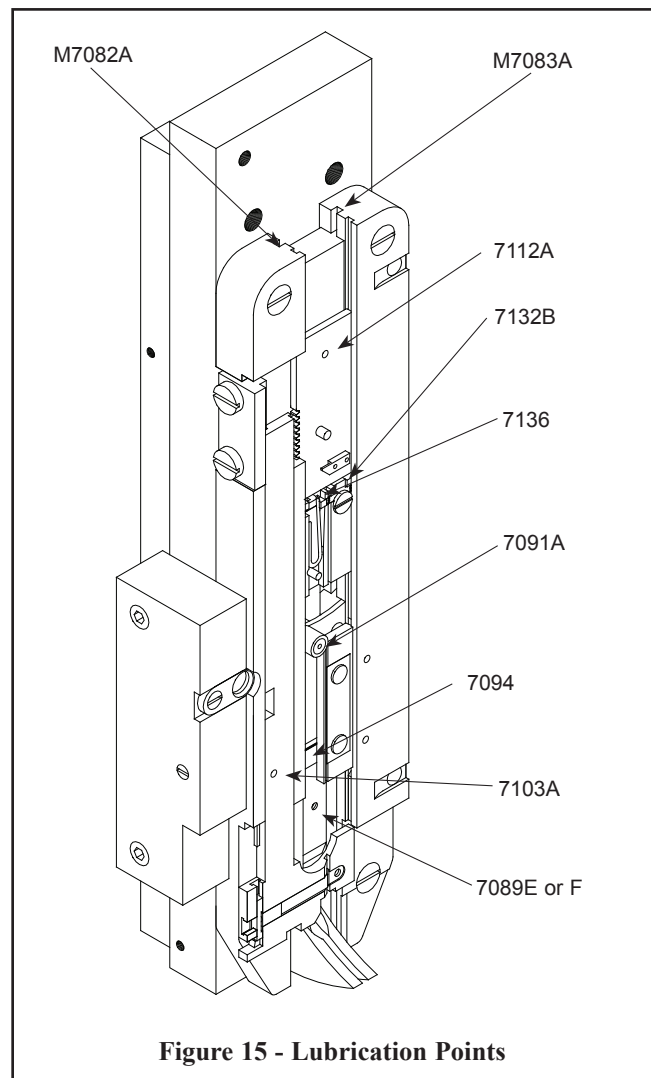

Figure 15 - Lubrication Points

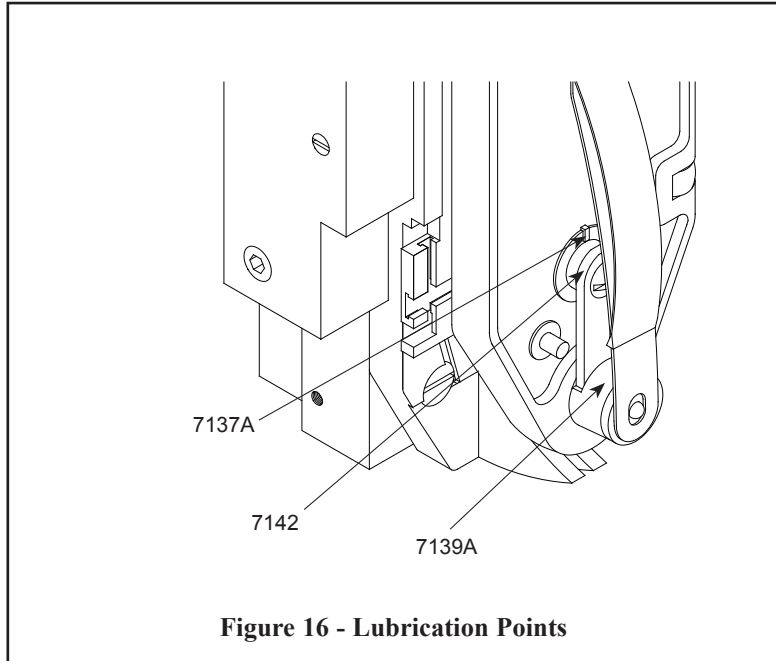

Figure 16 - Lubrication Points

Always disconnect the power supply before making any adjustments or servicing the stitcher.

⚠ WARNING

Cleaning

In addition to proper lubrication, routine cleaning is important for the maintenance of the M7 Stitcher Machine. The following areas should be cleaned every three months:

- **Swivel Assembly (7138A):** remove and wash in an oil-dissolving solvent, dry and relubricate.
- **Swivel Bushing (7139A):** clean inside the Swivel hole.
- **Anywhere that dust, oil or pieces of wire and paper have built up** - for example: the Grip, Clincher Points and around the Wire Straightener Rollers.
- **V-Belt (850730):** remove and reverse to check for cracking; a belt dressing may be applied periodically to extend the life of the belt. Also check for the proper tension in the belt.

Ordering Spare Parts

In time, you will need to replace some parts in the M7 Stitcher Machine. To do this locate the DeLuxe Stitcher part number in one of the following diagrams and contact your Graphic Arts Representative to order the replacement by part number, description and quantity.

Always disconnect the power supply before making any adjustments or servicing the stitcher.

WARNING

Replacing Spare Parts

The operator should periodically inspect all moving parts for signs of wear and when required, replace the worn parts. The Wire Cutters (7102), the Wire Grip (7132B) and the Driver (7089E) have been designed with duplicate cutting and gripping surfaces. When the original cutting or gripping surfaces show signs of wear, their position in the head can be reversed to provide a new working surface, which lengthens the life of the part. The following are some of the more common wear parts which will need to be removed and replaced in your M7 as well as step-by-step instructions to replace them.

Head Disassembly (Figures 17 & 18)

Some common wear parts are easily exchanged without removing the Face Plates from the M7 Stitcher Machine such as the **Wire Cutters (7102)**, the **Fixed Wire Grip (7132B)**, the **Driver (7089E or 9089F)** and the **Clincher Points (7024B)**. (See pages 26 through 29.)

But most wear part changes require the disassembly of one, if not both Face Plates (M7082A and M7083A). General disassembly instructions will be given first then a more specific description for each common wear part will follow.

Clear any remaining wire from the head and turn the machine over manually until the machine has finished a cycle, causing the Slider (G30015) and the Drive Link (G30096) to be in their up-most position. Disconnect the Supporter Spring Rod (7241) from the Supporter Assembly (7100A) which is located behind the head. Loosen the two (2) Wire Feed Adjusting Rack Screws (7219) and disengage the teeth of the Wire Feed Adjusting Rack (7113) and the teeth of the

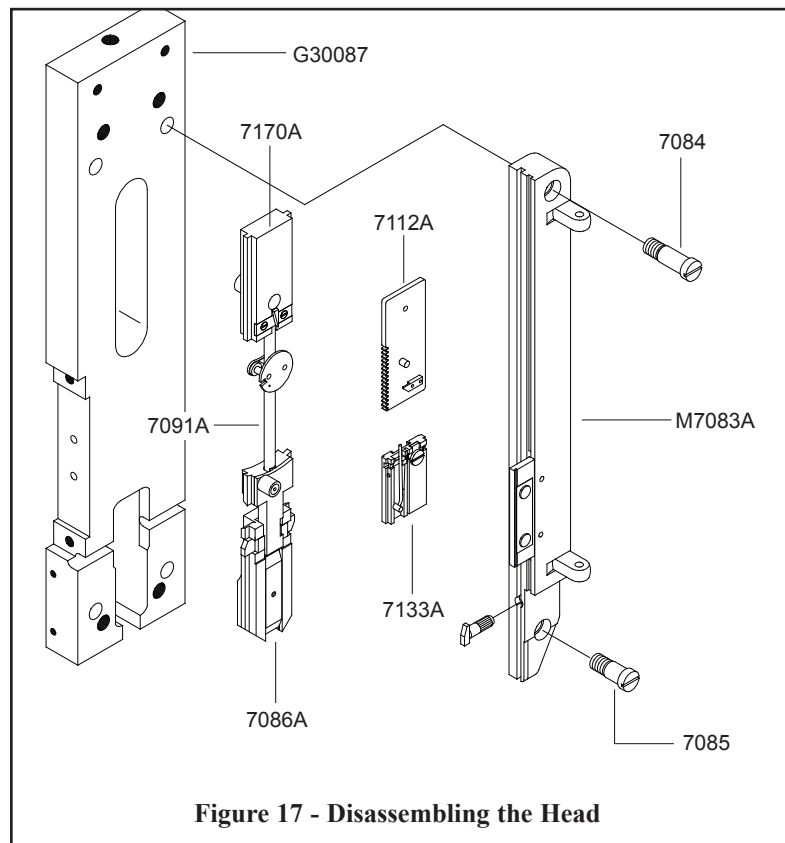

Figure 17 - Disassembling the Head

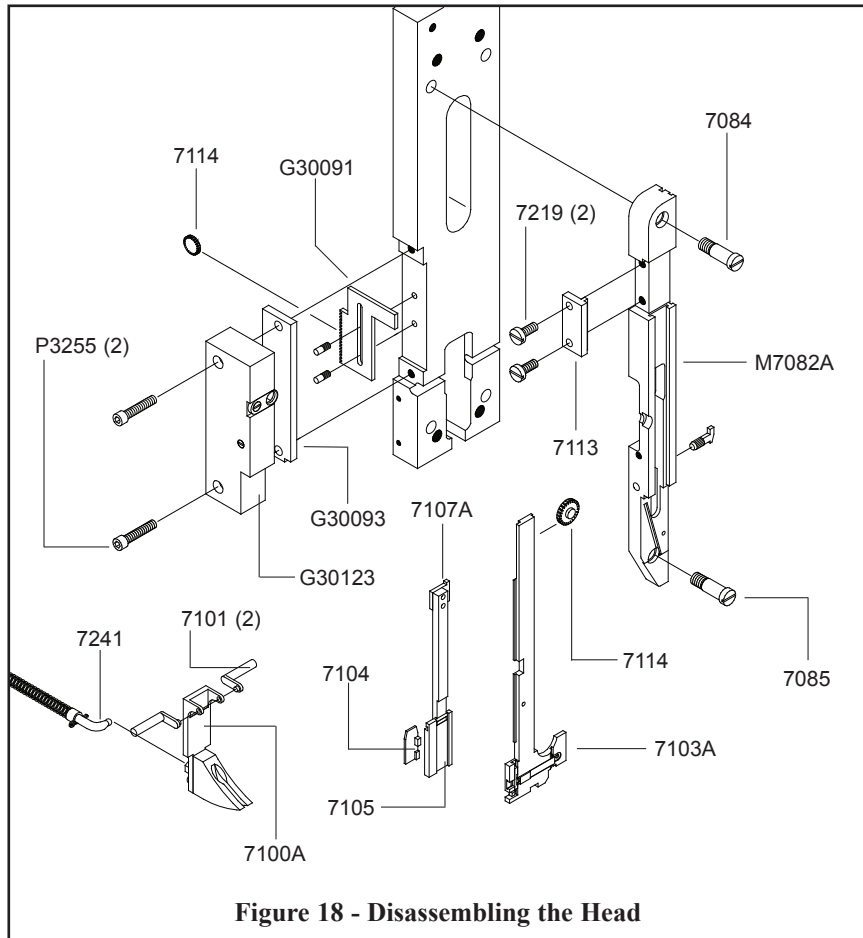

Figure 18 - Disassembling the Head

Wire Feed Adjusting Pinion (7114). While holding the Wire Feed Slide (7112A), loosen and remove the lower Face Plate Screw (7085) from the Right Face Plate (M7083A) as well as the upper Face Plate Screw (7084). Remove the Right Face Plate (M7083A) from the Face Plate Head Adapter (G30087) and remove the Adjusting Pinion to keep it from falling out of the head. The Upper Driving Bar (7170A), the Wire Grip Holder (7133A), the Driver (7091A) and the Bender Bar (7086A) assemblies can now be removed from the Left Face Plate (M7082A). Pay attention to the Wire Feed Slide (7112A) and the Wire Grip Holder since there is nothing supporting them once the assemblies

have been removed from the stitcher head.

Loosen the Screw (38) securing the Wire Cutter Slide Friction Plug (7204) in the Face Plate Latch Mount (G30123) and loosen and remove the two (2) Screws (P3255) from the Latch Mount itself. Carefully remove the Latch Mount from the Left Face Plate while paying close attention to the Wire Cutter Operating Slide Spring (7205) and the Friction Plug (7204). Remove the Adjuster Rack Cover Plate (G30093), the Lower Adjuster Rack (G30091) and the Wire Feed Adjusting Pinion (7114). Loosen and remove the lower Face Plate Screw (7085) as well as the upper Face Plate Screw (7084) so the Left Face Plate will be released from the Head Mounting Plate. Slide the Wire Cutter Holder out from the lower end of the Left Face Plate, being careful that the Wire Cutter Operating Slide Shoe (7104) does not disengage from the Wire Cutters (7102). When the Wire Cutter Holder is over a clean work area, the Shoe can be removed to release the Wire Cutters, the Wire Cutter Retainer (7109) and the Wire Holder Slide (7130). Once the Wire Cutter Holder is removed, the Wire Cutter Operating Slide Wedge (7105) and the Wire Cutter Operating Slide (7107A) can be removed from the Left Face Plate. Once both Face Plates have been removed the Supporter Assembly (7100A) and the Supporter Crank Links (7101) can be freed.

Always disconnect the power supply before making any adjustments or servicing the stitcher.

WARNING

Always disconnect the power supply before making any adjustments or servicing the stitcher.



Removing and Replacing the Wire Cutters (Figure 19)

The Wire Cutters (7102) have two cutting edges, each of which may be used by reversing ends and the position of the Cutters in the Wire Cutter Holder (7103A). When the Cutters are worn a burr is formed at the end of the cut piece of wire causing poor stitch quality. Check an unformed piece of wire from the Swivel Assembly. A properly cut piece of wire will be smooth on both ends. If it is not, the Cutters have to be reversed or replaced. To remove and replace the Cutters proceed as follows:

Open the stitcher Door Assembly (7137A) as previously described on page 10. Tap on the Wire Cutter Retainer (7109) to raise it out of the way and slide the upper Wire Cutter out from the Wire Cutter Holder. Raise the lower Wire Cutter to the position of the upper Wire Cutter and slide it from the Holder as well.

To reverse or replace the Cutters, first insert the new lower Wire Cutter into the Wire Cutter Holder, making sure that the slot in the center of the Cutter is toward the rear of the machine. Continue to slide the Cutter into the Cutter Holder until it drops down to its bottom position.

Slide the second Cutter into the Cutter Holder and then lower the Wire Cutter Retainer back into its operating position, locking the cutters in the holder. Position a screw driver just above the Wire Cutter Retainer (7109) and tap an indentation into the Wire Cutter Holder (7103A).

Turn the machine over manually to verify that the cutters are operating freely before running the machine under power.

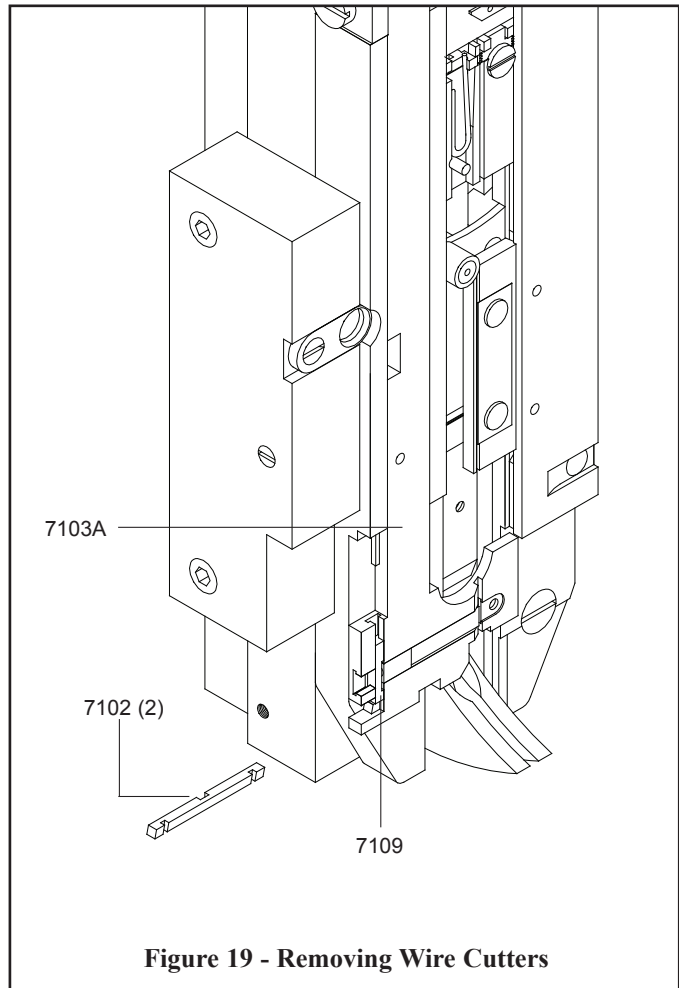

Figure 19 - Removing Wire Cutters

Always disconnect the power supply before making any adjustments or servicing the stitcher.

WARNING

Removing and Replacing Wire Grip and Wire Grip Spring (Figure 20)

The Fixed Wire Grip (7132B) has two saw-toothed gripping surfaces so that when the teeth show signs of wear, the Grip may be reversed to extend the life of the part. At the same time a new Wire Grip Spring (7134B) can be installed to replace a worn Spring. To remove and replace the Wire Grip or the Wire Grip Spring, proceed as follows:

Open the stitcher Door Assembly (7137A) as previously described and disengage the Wire Grip Spring (7134B) from the Moveable Wire Grip (7136). Unscrew the Wire Grip Spring Screw (7135) and remove the Fixed Wire Grip and the Wire Grip Spring from the Wire Grip Holder (7133A).

Reverse and replace the Grip in the Grip Holder, replace and tighten the Grip Retaining Screw. If both edges are worn, replace the part. Insert the shorter end of the Wire Grip Spring into the hole in the Wire Grip Holder, hook the longer end under the flange of the Wire Grip Holder and re-engage the Wire Grip Spring with the Moveable Grip.

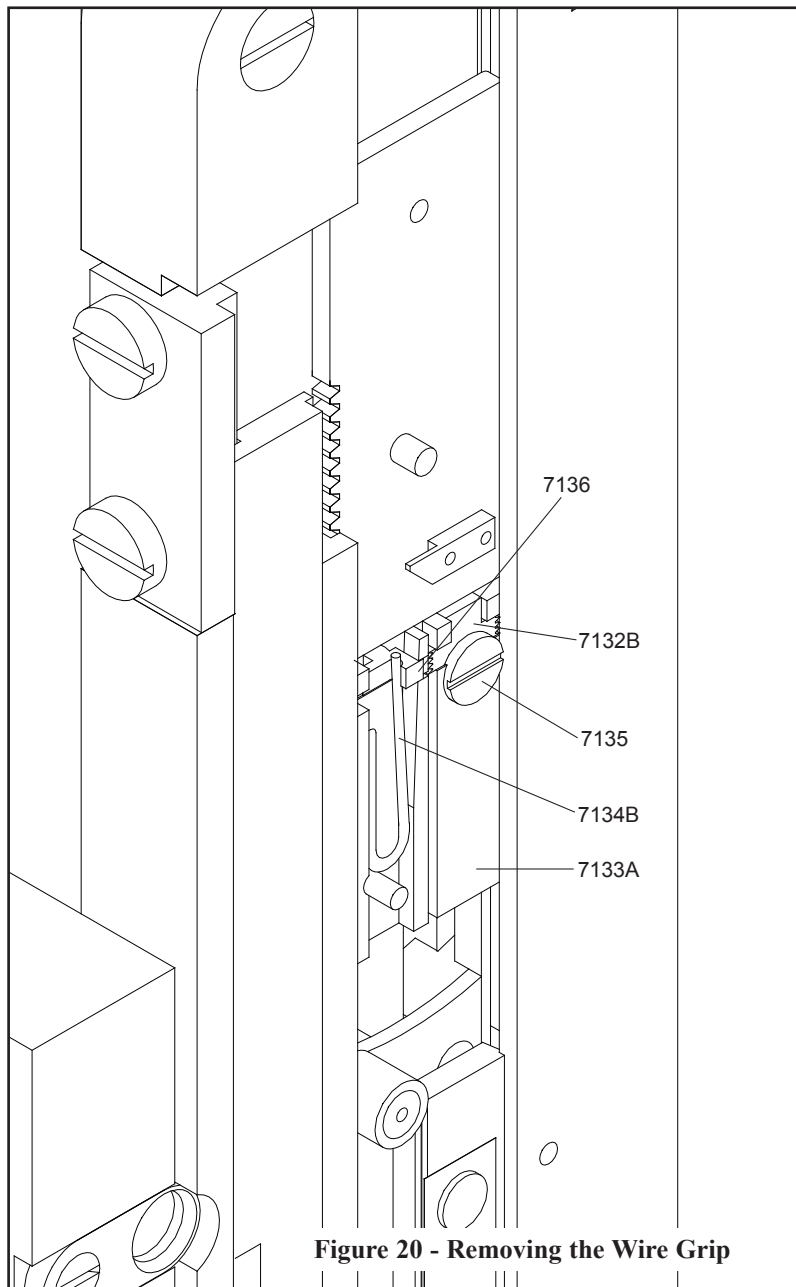
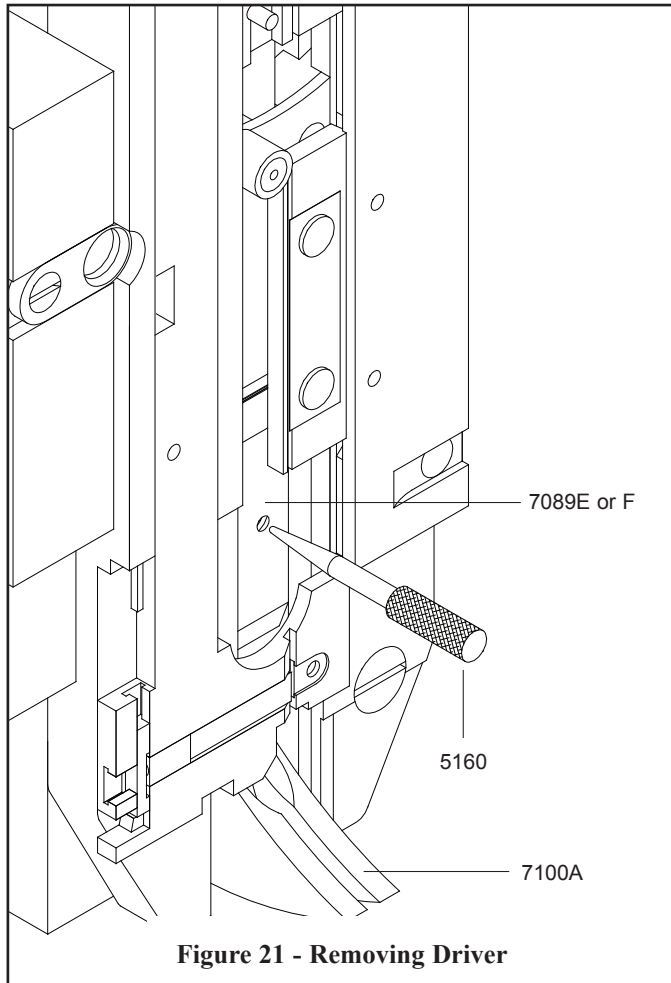

Figure 20 - Removing the Wire Grip

Removing and Replacing the Driver (Figure 21)



The Driver (7089E or F) is double-ended and when one end is worn or damaged it can be reversed to provide a new driving surface. To remove the Driver, first set the stitcher for maximum thickness of work (refer to page 11) Open the stitcher Door as previously described. Turn the machine over manually to the point where the Driver is at the highest position in the cycle but the release hole in the Driver is still accessible. Disengage the Supporter Spring Rod (7241) from the back of the Supporter (7100A) and then move the Supporter to its retracted position. Insert the Driver Release Pin (5160) supplied with the stitcher, into the release hole of the Driver and depress the Driver Spring. (7090) At the same time, push the Driver down until it can be withdrawn from the bottom of the Bender Bar (7086A). Replace the Driver by reversing the steps used to remove it, or if both edges are worn insert a new one. Turn the machine over manually to verify that the stitcher head is operating freely before running the machine under power.

Always disconnect the power supply before making any adjustments or servicing the stitcher.

WARNING

Always disconnect the power supply before making any adjustments or servicing the stitcher.

WARNING

Removing and Replacing the Clincher Points (Figure 22)

The Clincher Points (7024B or 7257B) are not reverseable as with other styles of Clincher Points but are easy to remove and replace. Loosen and remove the two (2) Screws (UA3806.16) and the two (2) Washers (PW14) securing the clincher Head Guard (G30121) to the Clincher Mount Assembly (G30044A) and remove it. Loosen and remove the two (2) Screws (9081) securing the Clincher Plate (7253A) to the Clincher Mount Assembly. Remove the Plate from the assembly, retract the Clincher Slide (18182) and swing the Clincher Points upward and pull them out of the Clincher Plate. Replace them with new Points and insert the Clincher Slide back into the Clincher Plate, making sure the Slide is fitted between the arms of the Clincher Points. Line the Clincher Plate up with the two (2) Clincher Plate Dowels (29) on the Clincher Mount Assembly again and replace the two (2) Screws. Replace the Head Guard and secure it with the Screws and Washers.

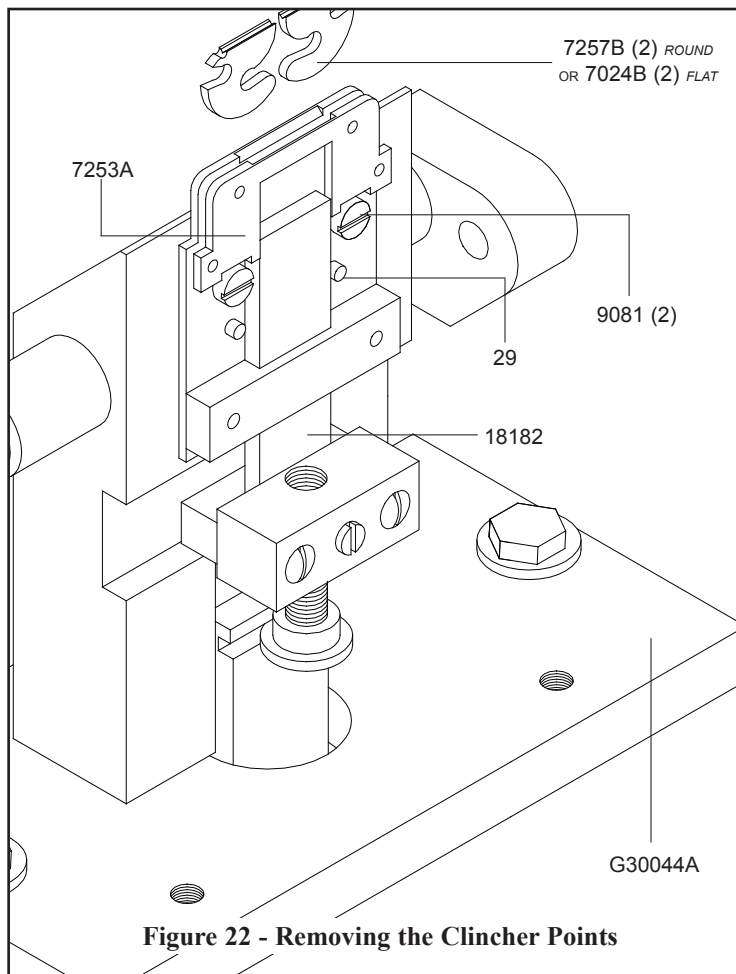

Figure 22 - Removing the Clincher Points

Rotate the machine manually to ensure the correct Clincher Point height prior to beginning work.

Removing and Replacing the Driving Bar Wedges (Figure 23)

The Right (7208) and Left Driver Bar Wedges (7095) push the Bender Bar Latch (7094) back and forth within the Bender Bar (7086A) to drive the Driver Bar Assembly (7091A) during each cycle of the M7. After time, these Wedges will wear and need to be replaced. A sure sign of this would be if partially formed staples are being produced. To remove the Driving Bar Wedges, it is necessary to first remove both the Right (M7083A) and Left Face Plate Assemblies (M7082A).

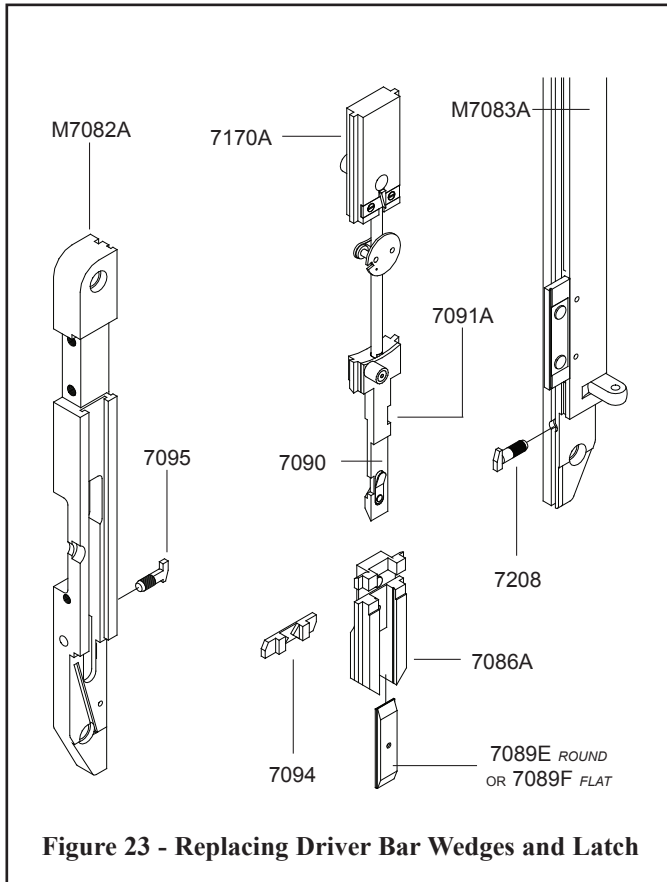

Figure 23 - Replacing Driver Bar Wedges and Latch

Start by removing the Face Plate assemblies (refer to the procedure explained on page 24). Once the Face Plates are off the Head Mounting Plate (G30092) look into the grooves of the Face Plates at the Wedges. If there are signs of wear, refer to **Figure 14**, use a punch and hammer to remove the old Bender Bar Wedges and replace them with new ones. Care should be taken when replacing the worn wedges so as to not deform them. Be sure to install the Wedges in line with the grooves of the Face Plates as well as correctly positioning the ramps of each Wedge. Refer to **Figure 23** for the correct orientation.

Note: Anytime the Wedges are replaced, the Driver Bar Latch should also be replaced.

Removing and Replacing the Latch (Figure 23)

The Driver Bar Latch (7094) controls the movement of the Driver Bar Assembly (7091A) and is itself, controlled by the Right (7208) and Left Driver Bar Wedges (7095). Before re-assembling the stitcher head, unlock the Wire Grip Holder (7133A) from the Feed Grip (7126A) for safe-keeping and proceed to change both the Latch and the Driver Bar Wedges. When replacing the Driver Bar Wedges (7095 and 7208) take care to install them in line with the grooves of the Right and Left Face Plates. In addition, be sure to orient the Wedge ramp correctly. See **Figure 23** for orientation.

Separate the Driver (7089E or F) from the Bender Bar by sliding the Bender Bar up enough to allow the Driver to disengage from the Driver Spring (7090). Once the Driver has been removed, the Driver Bar Assembly can be slipped out from the Bender Bar and the old Driver Bar Latch can be replaced. Inspect the old Latch before discarding. If the ends of the Latch are worn as well as the center, replace the Right and Left Driver Bar Wedges at this same time also (refer to the preceding section). Replace the Driver in the Bender Bar (see page 27), make sure that the new Latch moves freely under the Driver Bar Assembly and then reassemble the stitcher head. (see page 31)

Always disconnect the power supply before making any adjustments or servicing the stitcher.

⚠ WARNING

Always disconnect the power supply before making any adjustments or servicing the stitcher.

WARNING

Removing and Replacing the Wire Feed Shoes (Figure 24)

The Wire Feed Shoes (7154), when worn, cause inconsistencies in the wire draw since they may cause the wire to be pulled out of the Cutter Holder. In order to remove and replace the Wire Feed Shoes, the Right Face Plate Assembly (M7083A) has to be removed (see figure 17 for reference) as well as the Upper Driving Bar (7170A), the Driving Bar (7091A) and the Bender Bar assemblies (7086A). Be sure to remove the Wire Feed Slide (7112A) and the Wire Grip Holder (7133A) for safe-keeping.

Once the assemblies have been removed, loosen and remove the two (2) Driving Bar Wedge Screws (7088) from the Driving Bar Wedge (7173). Slip the entire Feed Grip Assembly (7126A) off the end of the Driver Bar. Remove the Wire Feed Shoe Spring (7190) and release the Wire Feed Shoes.

Install two (2) Wire Feed Shoes into the Feed Grip so that the small holes on the one end of each piece are facing up and opposite from each other, when looking at the back of the Feed Grip. In the tunnel created by the slots on the back of each Wire Feed Shoe, try to insert the Driver Bar Assembly. (Make

sure the side of the Driver Bar Assembly with the Swivel Operating Lever Cam Roll (7194) is on the same side as the notch in the Feed Grip. Refer to **Figure 24** for the correct orientation as this is critical. If this proves unsuccessful, file the small slot on the rear of both the Wire Feed Shoes with a 5/32" file so that the Driver Bar Assembly can be twisted between them while they are in place in the Feed Grip. The fit should be tight but still able to be adjusted by hand. A fit that is too tight will cause the brass Shoes to wear prematurely and a loose fit will cause inconsistent draw or cause the wire to be pulled from the Grip. When the fit is accurate, insert the Wire Feed Shoe Spring and twist it so the ends of the Spring are facing towards the small holes in the ends of the Wire Feed Shoes. Insert one end of the Wire Feed Shoe Spring into the hole in one of the Wire Feed Shoes. Compress the Spring to get the other end into the hole in the other Shoe.

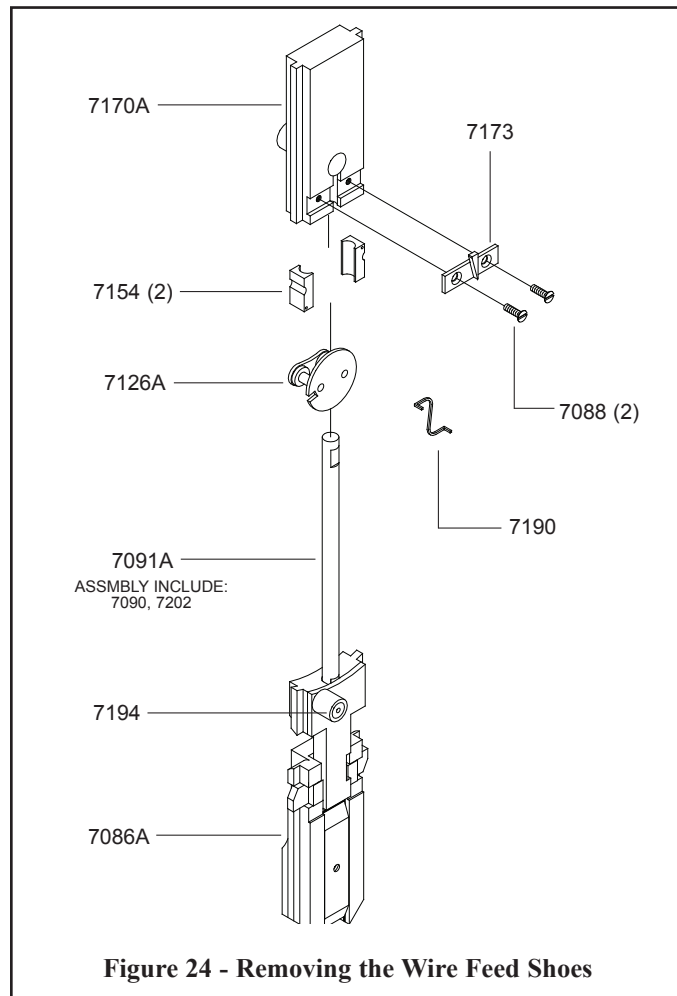

Figure 24 - Removing the Wire Feed Shoes

Do not operate the M7 under power until the machine has been turned over manually to verify that the stitching head is operating freely.

⚠ WARNING

Reassembly (Figures 25 & 26)

If the Left Face Plate (M7082A) has been disassembled refer to the following instructions. Replace the Wire Cutter Slide (M7107A) in the Left Face Plate and replace the Wire Cutter Operating Slide Wedge (7105) in its groove in the Face Plate. Engage the Wire Cutter Operating Slide Shoe (7104) with the Wire Cutters (7102) in the Wire Cutter Holder (7103A). Slide the Wire Cutter Holder into the groove in the Left Face Plate, making sure to line up the Shoe with the Shoe Wedge. (Sometimes it helps to turn the whole Left Face Plate Assembly upside down and allow gravity to hold the Shoe Wedge in place.) Turn the machine over manually until the Slider (66) and the Drive Link (G30096) are in their up-most position. Adjust the Hand Wheel (G30128) until there is a 1/4" space between the Adjuster Spool (G30119) and the lower Adjuster Stop (G30103). Attach the assembled Left Face Plate to the Head Mounting Plate (G30092) with the Upper (7084) and Lower (7085) Face Plate Screws. Install the upper Adjuster Rack (G30091) in the notch of the Wire Cutter Holder and over the two (2) Swivel Operating Sector Pins (7161). Replace the Wire Feed Adjustment Pinion (7114) between the two (2) Adjuster Racks. The Pinion should fit snugly but not have to be forced. If the Pinion does not fit without force, remove the lower Adjuster Rack (G30090) and replace it after putting the Pinion into place. Replace the Adjuster Rack Cover Plate (G30093) and the Face Plate Hinge Mount (G30123) and secure them with two (2) Screws (P3255). Make sure that the Wire Cutter Slide Friction Spring (7205) and Friction Plug (7204) are in position before securing the Latch Mount to the Left Face Plate. Tighten the Screw (38) and back off 1/2 of a turn. While the Screws are being tightened press the Latch Mount toward the front of the stitcher machine.

If the Left Face Plate was not disassembled, begin reassembly as follows: Replace the Supporter Crank Links (7101) and the Supporter Assembly (7100A) on the stitcher and

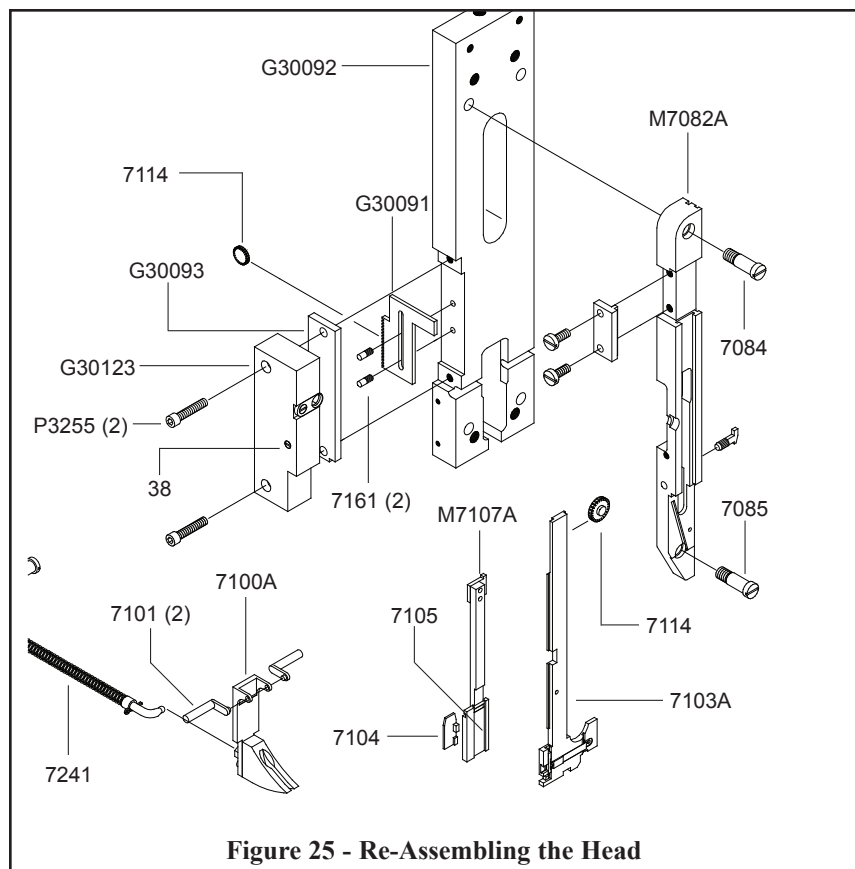

Figure 25 - Re-Assembling the Head

make sure there is free movement for the Supporter to pivot. Do not engage the Supporter Spring Rod (7241) with the Supporter Assembly at this point. Insert the Bender Bar (7086A), Driver Bar (7091A), Feed Grip (7126A) with the Wire Grip Holder (7133A) attached and Upper Driving Bar (7170A) assemblies into their grooves in the Left Face Plate, while engaging the Upper Driving Bar with the Drive Link (G30096).

Note: position the Driver Bar sub-assembly approximately the same as that shown in Figure 26.

Insert the Wire Feed Adjusting Pinion (7114) behind the Wire Cutter Holder. Slide the Wire Feed Slide (7112A) over the

Driving Bar Wedge (7173) on the Upper Driving Bar and insert the Slide in its groove in the Left Face Plate. Slide the Right Face Plate into position, lining up its grooves with the assemblies already in the Left Face Plate and insert the lower (7085) and upper Face Plate Screws (7084) and tighten. Re-engage the Supporter Spring Rod (7241) with the Supporter Assembly (7100A).

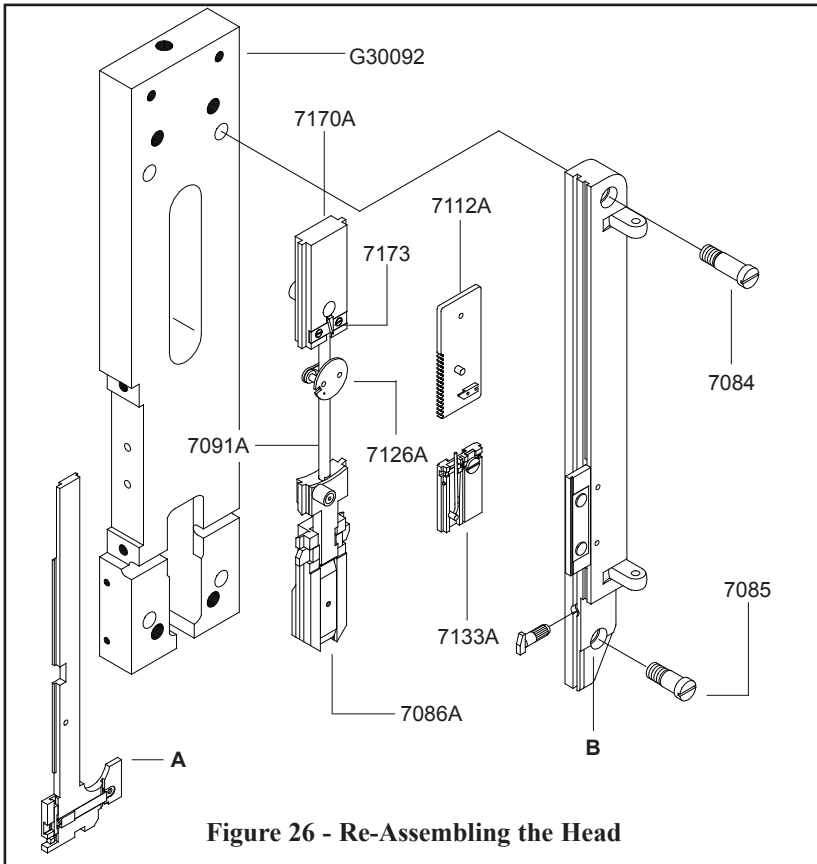

Figure 26 - Re-Assembling the Head

Set the stitcher's compression to its minimum setting with the Hand Wheel (G30128). Make sure the two (2) Screws (UA4108.1) that support the Upper Adjuster Rack (G30090) are loose. Insert the Wire Feed Adjusting Pinion (7114) into the teeth of the Upper Adjuster Rack. Tighten the two (2) Screws (UA4108.1) when the Rack is centered between the Adjuster Fork (G30031B) and the ledge on the Face Plate Head Adapter. Move the Wire Cutter Holder (7103A) until Point "A" is 1/8" above the ledge at Point "B" on the Right Face Plate Assembly (M7083A). Install the Lower Adjuster Rack (G30091) over the two (2) Swivel Operating Sector Pins (7161) and line it up with the Wire Feed Adjusting Pinion (7114). Hold this position until the Adjuster Rack Cover Plate (G30093) and the Face Plate Latch Mount (G30123) are tightly secured to the Head Mounting Plate (G30092) with two (2) Screws (P3255). Tighten the two (2) Screws (UA4108.1). Lower the Wire Feed Slide Assembly (7112A) until the second tooth from the top begins to engage the teeth of the Wire Feed Pinion (7114) in the Wire Cutter Holder. Tighten the Wire Adjusting Rack Screws (7219) to secure this position after engaging the Wire Feed Adjusting Rack (7113) with the Wire Feed Pinion. Make sure the Door Assembly still latches in the Door Latch Catch (7199) securely. Please realize these settings are an approximation. Fine tuning is required before operating the M7 Stitcher. **Refer to page 16 for other adjustments and settings that should be completed before the stitcher is run under power.**

Clutch-Brake Maintenance

Always disconnect the power supply before making any adjustments or servicing the stitcher

 **WARNING**

This stitcher is equipped with a solenoid actuated, continuous trip, wrap spring clutch-brake unit. It is a dependable device and seldom needs service. But should a malfunction occur, the following information is a service and troubleshooting guide for the maintenance of this unit.

Actuator

The actuator is a simple, straight-forward mechanical linkage. When the actuator does not trip, the following checks should be made. Refer to **Figure 27** for more details.

Problem	Cause and Remedy
No power to the Coil	Check all wiring and switching in the Clutch actuating system.
Lack of continuity in the Coil Windings	Replace the Coil (850998 - 230 VAC or 850999 - 115 VAC)
Mechanical binding of the Plunger	The Coil may have shifted or the Plunger end may have mushroomed due to striking the Backstop. In the latter the Plunger may be filed to its true diameter.
Insufficient clearance for the Actuator over the Stop Collar	Adjust the Linkage as needed
Actuator loaded by the Stop Collar so hard that the Actuator cannot be pulled by the Coil.	Braking force is exceeding the limits of the Brake or the Differential setting of the unit is too close (see Figure 30 for instructions)

Figure 27 - Actuator Checklist

Clutch and Brake Springs

With the brake engaged (full limit of output), the input hub should be free to rotate by hand. With the clutch engaged, the input and output hubs should rotate together. If the unit does not rotate in either of these modes, the clearance between the hubs of the unit on the shaft may have been disturbed or damaged. See Assembly/Disassembly instructions for re-adjusting.

Listed below are additional checks to be made if the clutch does not function correctly. Refer to **Figure 28** for details.

Problem	Cause and Remedy
Clutch Brake does not drive but Input Motor turns	<ol style="list-style-type: none"> 1. Drive Spring (850889) may be broken at the crossover point from an overload caused by a jam. Replace the Spring and check the Hubs (851321 or 850892) for damage. 2. The Control Collar (850888) may not snap forward because of foreign matter is restricting movement. Clean the unit. 3. Actuator Assembly does not pull in. (Figure 28)
Clutch Brake jams and stalls Input Motor	<ol style="list-style-type: none"> 1. Spring tang broken off Drive Spring not allowing the Clutch to disengage while the Brake is engaged. Replace the Drive Spring. 2. Clutch output is bound up. Check the clearance between the Output Hub and the Brake Hub. 3. Completely out of adjustment caused by losing an internal Spring tang. Replace Spring.
Output does not repeat stopping point	<ol style="list-style-type: none"> 1. Not enough inertia to actuate Brake. 2. Tang broken off the Brake Spring. Replace the Spring. 3. Adjustable Collar Locking Screw may be loose allowing Adjusting Screw to rotate.

Figure 28 - Clutch and Brake Spring Checklist

Disassembly (See figure 29)

To disassembly the Clutch-Brake unit (850677 or 850678) it will be necessary to remove the Drive Pulley (7678) from the stitcher by removing the V-Belt (850730), Retaining Ring (P7863), and Clutch Anchor Screw (7681). Disconnect the Ground and Solenoid wires, and swing the anchor strap (FC9656) clear of the Drive Pulley Assembly and slide it off of the Drive Shaft. Remove the three (3) Screws (UA4812.7) connecting the Drive Pulley to the Clutch-Brake unit.

When disassembling the Clutch-Brake unit, always mark the Spring Tang locations with reference to which slots they go in if the same Springs are to be used for reassembly. To disassemble the Clutch-Brake unit, proceed as follows:

Release the Actuator Lever so that the Clutch is engaged and the Brake is released. Remove the Retaining Ring and the Shim Washer, if any, from the Input Hub (851321) end. Remove the Input Hub by rotating opposite to the drive direction. Remove the Retaining Ring and the Shim Washer, if any, from the Mounting Plate end.

Remove the Output Shaft Springs and the Control Collar (850888) Assembly by rotating the Output Shaft (850891) in the drive direction. **(Do not disassemble the brake Hub (850892) from the Mounting Plate. (850890))** Remove the Control Collar from the Output Shaft and the Spring Assembly by extracting toward the Brake Spring end.

Assembly (See figure 29)

Replace the Clutch (850889), Brake (850889) and Anti-Back (850962) Springs as required. Assemble the Springs concentric and square to the Output Shaft.(850891) Assemble the Control Collar over the Output Shaft and Spring Assembly by inserting it from the Brake Spring End (it will be necessary to extend the Brake Springs using long nose pliers.) Place the Brake Spring Tang in any one (1) of the nine (9) Control Collar slots at random.

Assemble the Output Shaft, Springs and Control Collar assembly to the Mounting Plate Assembly by rotating the Output Shaft in the drive direction. Assemble the Retaining Ring (850886) to the Output Shaft at the Mounting Plate end (the smooth surface facing the Brake Hub.) Check the end play between the Hub and the Retaining Ring with a feeler gauge. There should be 0.004” to 0.010” end play. Use a Shim Washer to adjust if necessary.

Rotate the Output Shaft in the drive direction until it reaches a full brake position. With the Clutch Spring Tang **NOT** in slot, insert the Input Hub (851321) by rotating opposite to the drive direction. Select one (1) of ten (10) Control Collar slots for the Clutch Spring Tang that will provide a 0.38” to 0.50” circumferential overtravel of the Control Collar when released.

Note: At this point it may be necessary to reselect one (1) of the nine (9) Control Collar slots for the Brake Spring Tang (release Actuator Lever, remove the Clutch Spring tang from the slot, then move Control Collar axially toward the Input Hub end and rotate it opposite to the drive direction to pick up the next slot). Continue to select Control Collar slots until the 0.38" to 0.50" specification is achieved.

Assemble the Retaining Ring to the Output Shaft at the Input Hub end (the smooth surface facing the Input Hub). Check the end play between the Input Hub and the Retaining Ring with feeler gauge. There should be 0.002" to 0.003" end play on the Input Hub.

Reassemble the unit to the machine.

Note: After the Clutch is assembled to the machine, the Clutch Plate should be free to float on bearing - the Anchor Strap is only there to prevent rotation of the plate.

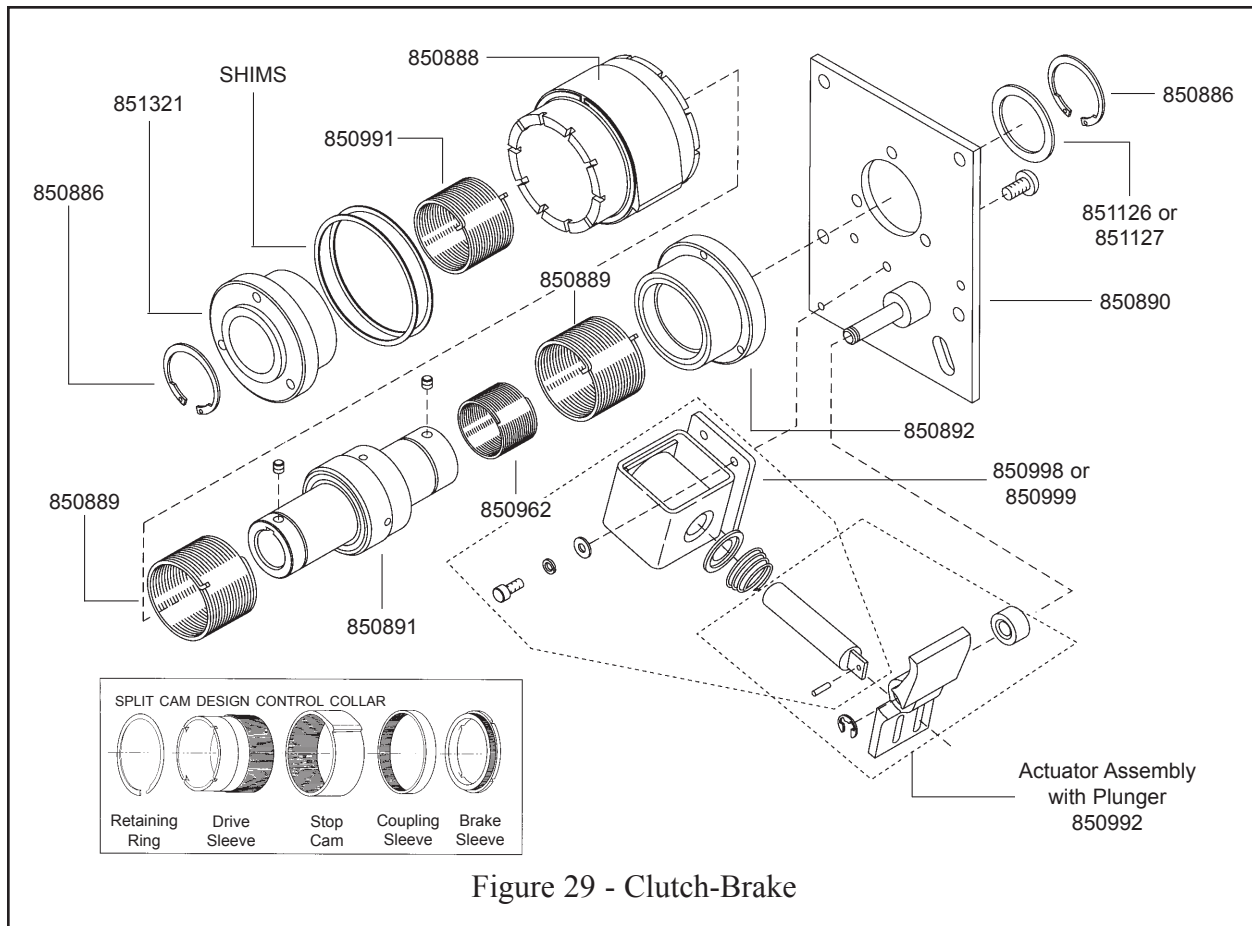

Lubrication

The clutch-brake unit is designed with the bearing parts made from sintered metal that has been impregnated with oil and normally do not need to be re-lubricated. In cases where there is severe duty, the unit may be re-oiled or flushed out with minimal or no disassembly by using a light bearing oil as used in manufacture (Shell Bearing Infusion Oil #33). If disassembly of the unit for cleaning and oiling is necessary, follow the detailed disassembly instructions to the point needed, flush and wipe parts in the oil to be used for re-lubrication. **Do not use solvents** to clean the parts. To get more cleaning action for the oil, it may be heated while cleaning the components, but bring the parts back to ambient temperature submerged in cool oil.

Coil Replacement

Place the spring onto the plunger with the narrow end towards the actuator. Slide the solenoid onto the actuator and plate assembly. Assemble the solenoid to the plate assembly with the cap screws and washers. **Do not tighten** more than finger tight.

Energize the coil and adjust the gap between the actuator and the top of the collar stop to 0.015" to 0.030" by sliding the solenoid assembly.

Note: Push the collar toward the actuator to allow for collar movement. Tighten the cap screws.

Control Collar Adjustment (Figure 30)

The stopping position of the head can be changed if necessary by adjusting the position of the stop cam on the control collar sleeve. Turn the machine manually until the driver is in the desired stopping position, then proceed as follows:

Work the Retaining Ring (850886) out of its groove and slide it forward on the Input Hub (851321). Slide the cam of the Control Collar Assembly (850888) off of the splines, rotate to align the collar stop with the actuator and slide the cam back on the splines. The actuator pawl will have to be held clear during this operation. Slide the retaining ring back into its groove.

Make sure brake is locked up before proceeding, to insure the proper stop point.

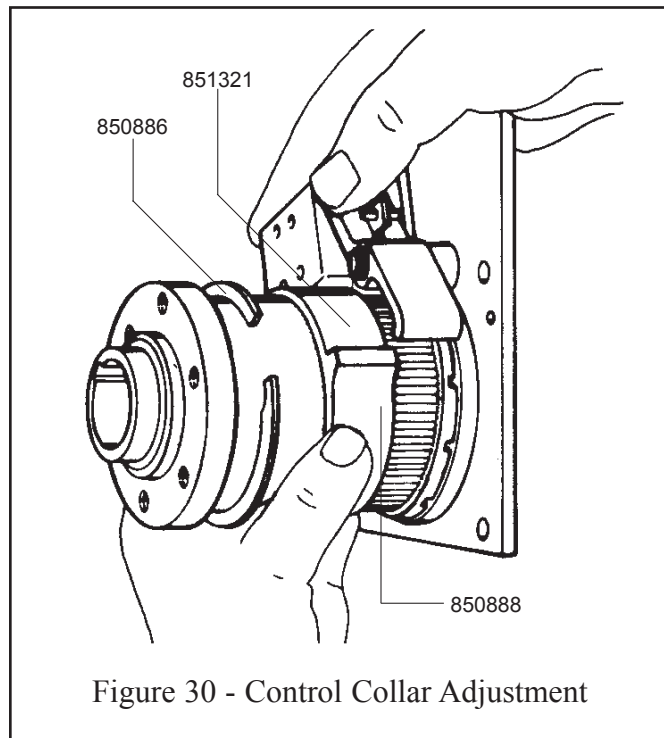
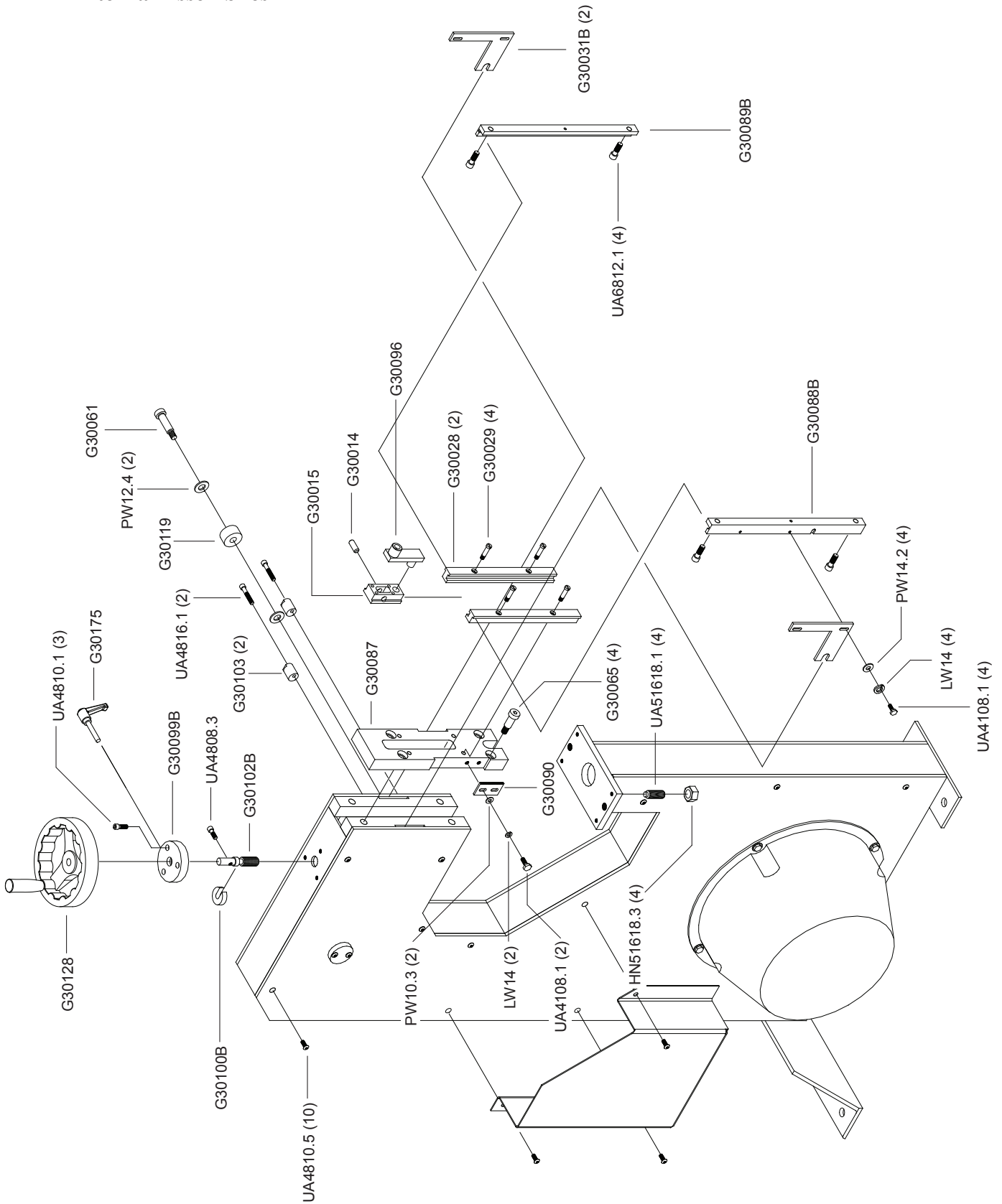

Figure 30 - Control Collar Adjustment

External Assemblies



External Assemblies

PART No.	DESCRIPTION	QUANTITY
G30014	Slider Pin	1
G30015	Slider	1
G30028	Slider Guide	2
G30029	Slider Guide Screws	4
G30031B	Adjuster Fork	2
G30061	Screw 1/2 x 1 - 1/2	1
G30065	Screw 1/2 x 1	4
G30087	Face Plate Head Adapter	1
G30088B	Head Guide Plate - Left	1
G30089B	Right Head Guide Plate	1
G30090	Adjuster Rack - Upper	1
G30096	Drive Link Assembly	1
G30099B	Adjuster Crank Housing	1
G30100B	Adjuster Crank Shaft Insert	1
G30102B	Adjuster Shaft Screw	1
G30103	Adjuster Stop	2
G30119	Adjuster Spool	1
G30128	Hand Wheel	1
HN51618.3	Hex Jam Nut 5/16-18	4
LW14	Lock Washer 1/4	6
PW10.3	Washer 3/16	2
PW12.4	Washer 1/2 - Black	2
PW14.2	Washer Zinc 1/4	4
UA4108.1	Screw 1/4 - 20 x 1/2	6
UA4808.3	Screw 1/4 - 20 x 1/2	1
UA4810.1	Screw 1/4 - 20 x 5/8	3
UA4810.5	Screw 1/4 - 20 x 5/8	10
UA4816.1	Screw 1/4 - 20 x 1	2
UA51618.3	Screw 5/16-18 x 7/8	4
UA6812.1	Screw 3/8 - 16 x 3/4	4

Clincher and Table Assemblies

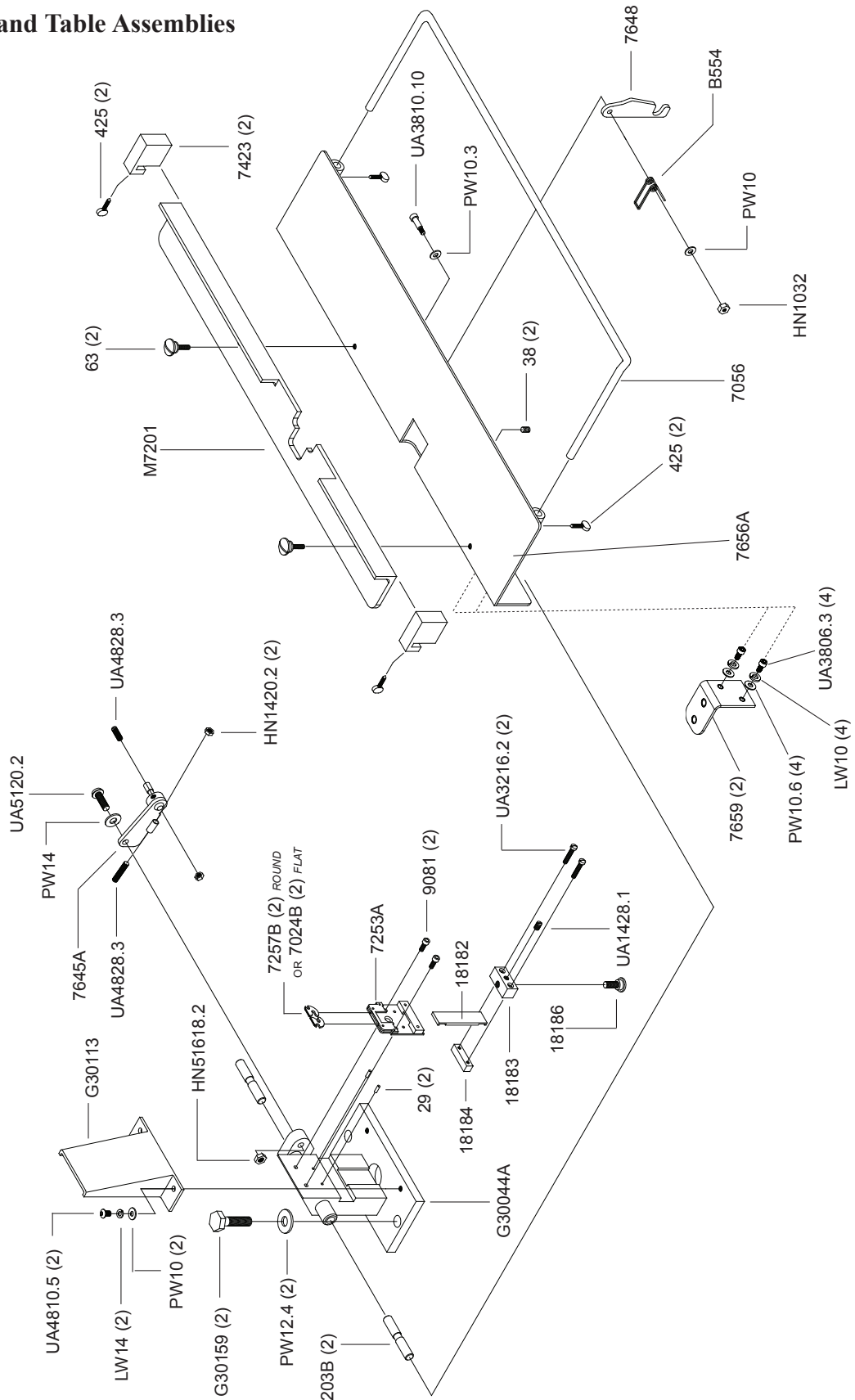

Clincher and Table Assemblies

PART No.	DESCRIPTION	QUANTITY
B554	Torsion Spring	1
G30044A	Clincher Mount Assembly	1
G30113	Clincher Guard	1
G30159	Screw 1/2-20x1-1/4	2
HN1032	Nut 10 - 32	1
HN1420.2	Hex Jam Nut 1/4 - 20	2
HN51618.2	Hex Jam Nut 5/16-18	1
LW10	Lock Washer #10	4
LW14	Lock Washer 1/4	2
M7201B	Work Guide	1
PW10	Washer #10	3
PW10.3	Washer 3/16	1
PW10.6	Washer #10	4
PW12.4	Washer Black 1/2	2
PW14	Washer 1/4	5
UA1428.1	Screw 1/4 - 28 x 1/4	1
UA3216.2	Clincher Slide Block Screw	2
UA3806.3	Screw #10-32 x 3/8	4
UA4810.5	Screw 1/4 - 20 x 5/8	2
UA3810.10	Screw 1/4 x 5/8	1
UA4828.3	Screw 1/4 - 20 x 1-3/4	2
UA5120.2	Screw 5/16 - 18 x 1-1/4	1
18182	Clincher Slide	1
18183	Clincher Slide Adjustment Block	1
18184	Clincher Slide Block Clamp	1
18186	Clincher Slide Adjustment Screw	1
203B	Work Table Swivel Pin	2
29	Dowel	2
38	Clincher Slide Adjustment Screw	2
425	Wire Guide Spring Holder Screw	4
63	Work Guide Screw	2
7024B	Clincher Point, Flat - 1/2	2
7056	Work Table Extension	1
7253A	Clincher Plate - 1/2	1
7257B	Clincher Point, Round - 1/2	2
7423	Work Stop	2
7645A	Table Support Bracket	1
7648	Table Support	1
7656A	Work Table Assembly	1
7659	Table Extender Bracket	2
9081	Screw	2

Internal Assemblies

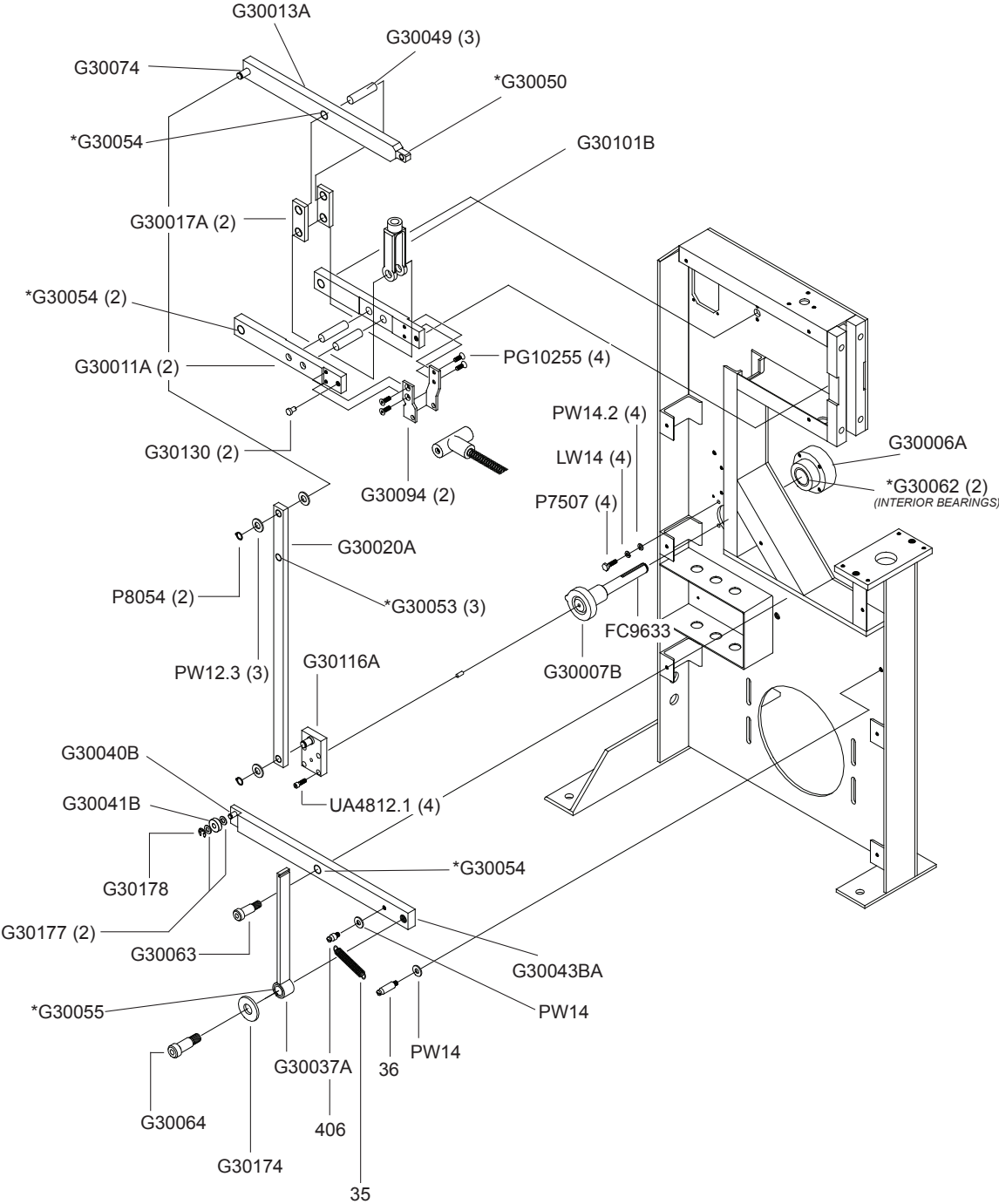

* - CONTAIN BEARINGS WHICH CAN BE PURCHASED SEPARATELY

Internal Assemblies

PART No.	DESCRIPTION	QUANTITY
FC9633	Key	1
G30006A	Bearing Housing Assembly	1
G30007B	Crank Shaft Assembly	1
G30011A	Adjuster Lever Assembly	2
G30013A	Drive Lever Assembly	1
G30017A	Pivot Link Assembly	2
G30020A	Upright Link Assembly	1
G30037A	Clincher Upright Link Assembly	1
G30041B	Clincher Roller Assembly	1
G30043BA	Clincher Lever Assembly	1
G30049	Dowel Pin 5/8 x 2-1/2	3
G30063	Screw 5/8 x 1	1
G30064	Screw 3/4 x 1-1/4	1
G30094	Supporter Spring Bracket	2
G30101B	Adjuster Yoke	1
G30116A	Crank Throw Assembly	1
G30130	Adjuster Stud	2
G30174	Spacer - M Series	1
G30177	Flat Washer	2
G30178	Retaining Ring	1
LW14	Lock Washer 1/4	4
P7507	Screw 1/4 - 20 x 3/4	4
P8054	Retaining Ring	2
PW12.3	Washer Zinc 1/2	3
PG10255	Screw 1/4 - 20 x 5/8	4
PW14	WASHER 1/4	2
PW14.2	Washer Zinc 1/4	4
UA4810.5	Screw 1/4 - 20 X 5/8	2
UA4812.1	Screw 1/4 - 20 x 3/4	4
35	Clincher Slide Link Spring	1
36	Pin	1
406	Clincher Oper. Lever Spring Screw	1

Wire and Guard Assemblies

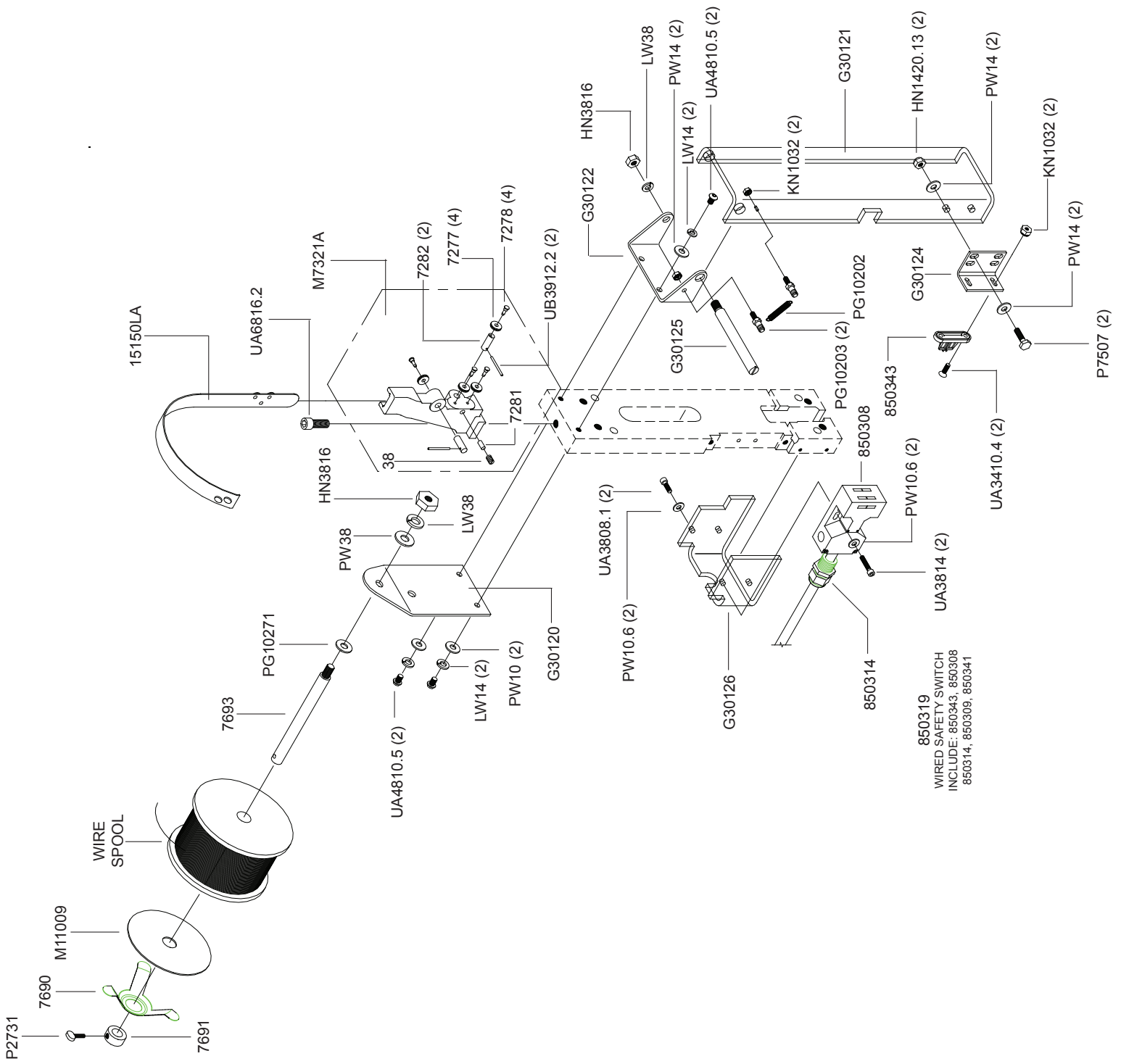

Wire and Guard Assemblies

PART No.	DESCRIPTION	QUANTITY
G30120	Wire Spool Bracket	1
G30121	Head Guard	1
G30122	Guard Mounting Bracket	1
G30124	Actuator Key Bracket	1
G30125	Head Guard Pivot	1
G30126	Fixed Head Guard	1
HN1420.13	Nut 1/4 - 20 Nylon	2
HN3816	Hex Nut 3/8 - 16	2
KN1032	Kep Nut 10 - 32	4
LW14	Lock Washer 1/4	4
LW38	Lock Washer 3/8	2
M11009	Plastic Washer	1
M7321A	Wire Straightener	1
PG10202	Tension Spring	1
PG10203	Screw 4 - 40 x 1/2	2
PG10271	Washer 9/16	1
PW10	Washer #10	2
PW10.6	Washer - S.A.E. #10	4
PW14	Washer 1/4	6
PW38	Washer 3/8	1
P2731	Thumb Screw 1/4 - 20 x 3/4	1
P7507	Screw 1/4 - 20 x 3/4	2
UA3410.4	Screw 10 - 32 x 5/8	2
UA3806.16	Screw 1/4 - 20 x 3/8	4
UA3808.1	Screw 10 - 32 x 1/2	2
UA3814	Screw 10 - 32 x 7/8	2
UA4810.5	Screw 1/4 - 20 x 5/8	4
UA6816.2	Screw 3/8 - 16 x 1	1
UB3912.2	Spirol Pin	2
15150LA	Wire Guide Spring	1
38	Clincher Slide Adjustment Screw	1
7277B	Wire Straightener Roller	4
7278	Wire Straightener Roller Stud	4
7281	Wire Straightener Ecc. Friction Plug	1
7282	Wire Straightener Eccentric	2
7690	Tension Spring	1
7691	Set Collar - Reamed	1
7693	Spool Stud	1
850308	Safety Interlock Switch	1
850314	Strain Relief	1

Motor Assemblies

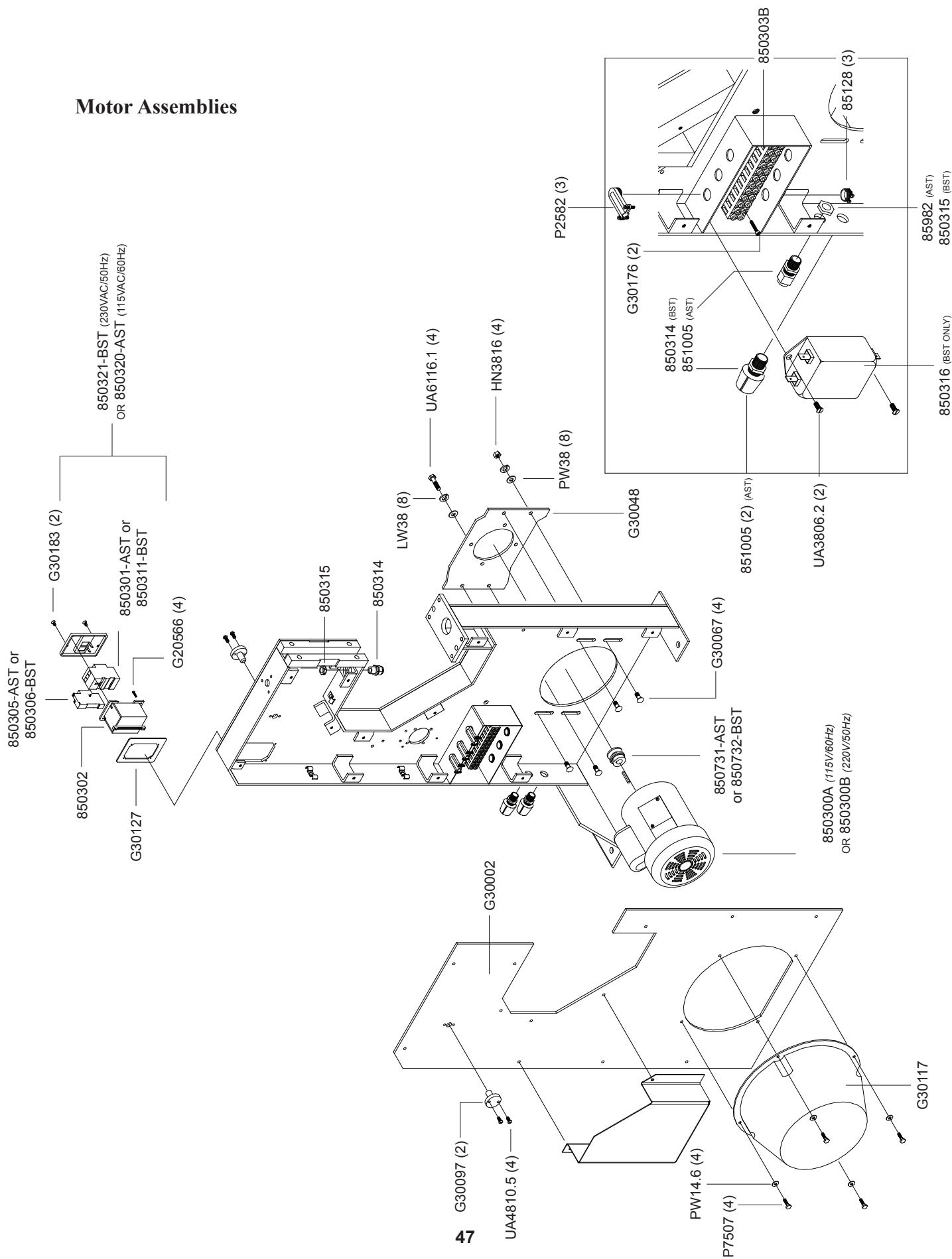

Motor Assemblies

PART No.	DESCRIPTION	QUANTITY
G30002	Side Cover Plate - Left	1
G30048	Motor Mounting Plate	1
G30067	Bolt 3/8 - 16 x 1	4
G30097	Adjuster Pivot Pin	2
G30117	Motor Cover	1
G30127	Starter Mounting Flange	1
G30176	Screw M4 x 0.7 x 25	2
G30183	Screw, Tap 6 x 3/8	2
G20566	Screw M4 x 0.7 x 20	4
HN3816	Hex Nut 3/8 - 16	4
LW38	Lock Washer 3/8	8
PW14.6	Washer 1/4	4
PW38	Washer 3/8	8
P2582	Connector 3/8 x 90 Degrees	3
P7507	Screw 1/4 - 20 x 3/4	4
UA3304.2	Screw 10 - 32 x 1/4	2
UA4810.5	Screw 1/4 - 20 x 5/8	4
UA6116.1	Screw 3/8-16 x 1	4
850300A	Motor 1/2 HP - 115V	1
850300B	Motor 1/2 HP - 230V	1
850303B	Terminal Strip	1
850314	Strain Relief - BST Models	3
850315	Strain Relief Nut - BST Models	2
850316	RFI Filter, AC Noice	1
850320	Starter Assembly 1/2, 115V	1
850321	Starter Assembly 1/2, 230V	1
850731	Pulley - AK15 - 5/8	1
850732	Pulley AK17 x 5/8	1
851005	Strain Relief	2
85128	Connector 3/8	3
85982	Lock Nut	2

Guard Assembly

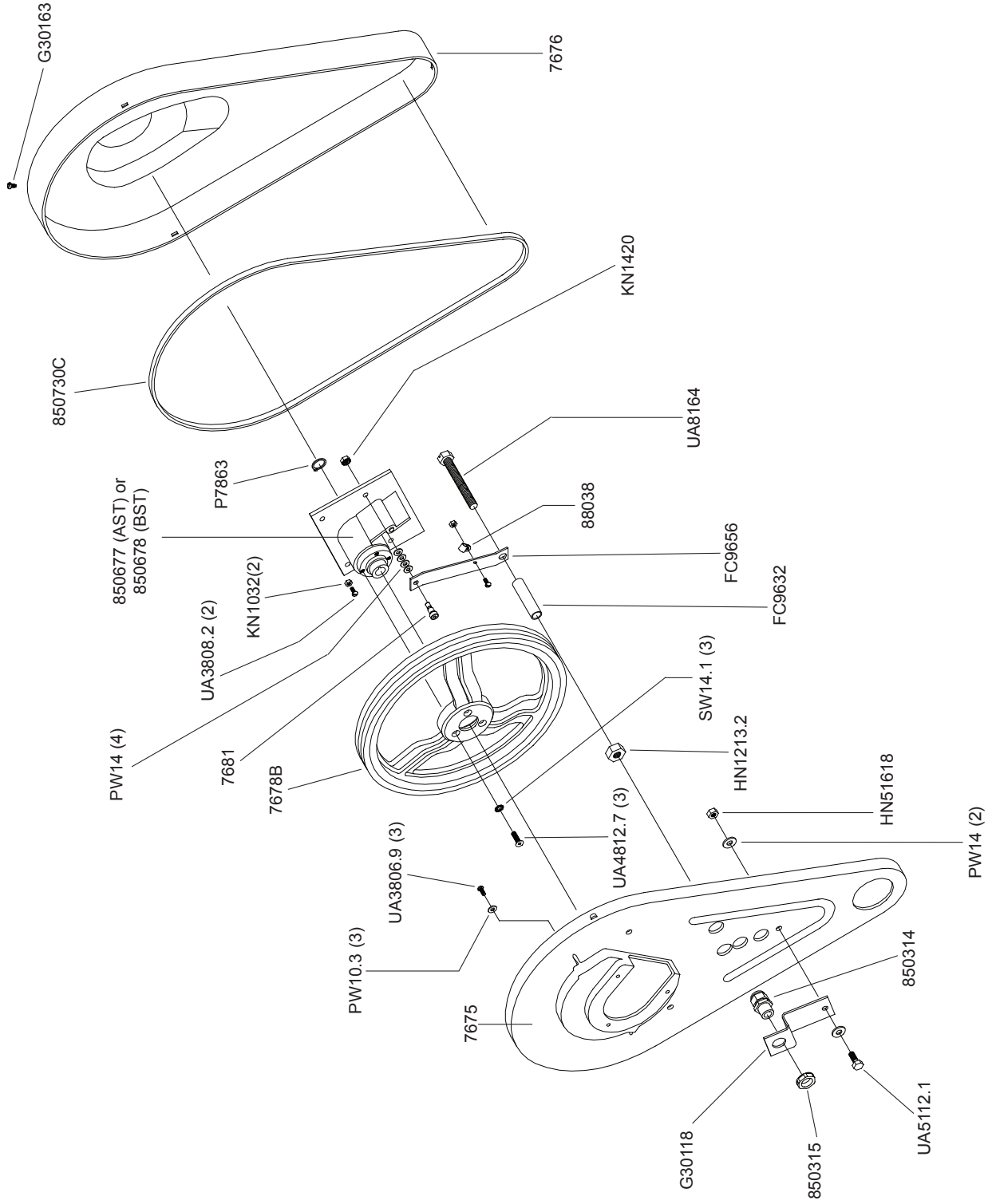

Guard Assembly

PART No.	DESCRIPTION	QUANTITY
FC9632	Anchor Spacer	1
FC9656	Clutch Anchor	1
G30118	Belt Guard Bracket	1
G30163	Self Tap Screw #10 x 3/8	1
HN1213.2	Nut 1/2 - 13	1
HN51618	Hex Nut	1
KN1032	Kep Nut	2
KN1420	Kep Nut 1/4	1
PW10.3	Washer 3/16	3
PW14	Washer 1/4	6
P7863	Retaining Ring	1
SW14.1	Lock Washer	3
UA3806.9	Screw #10 - 32 x 3/8	3
UA3808.2	Screw #10 - 32 x 1/2	4
UA4812.7	Screw 1/4 - 20 x 3/4	3
UA5112.1	Screw 5/16 - 1/ x 3/4	1
7675	Belt Guard	1
7676	Belt Guard	1
7678B	Drive Pulley - 4L	1
7681	Screw Clutch Anchor	1
850678	Electric Clutch - 230V	1
850314	Strain Relief	1
850315	Strain Relief Nut	1
88038	Nylon Cable Clamp	1
850677	Electric Clutch - 115V	1
850730C	V-Belt 1/2 x 60	1

The M7 Stitcher Machine

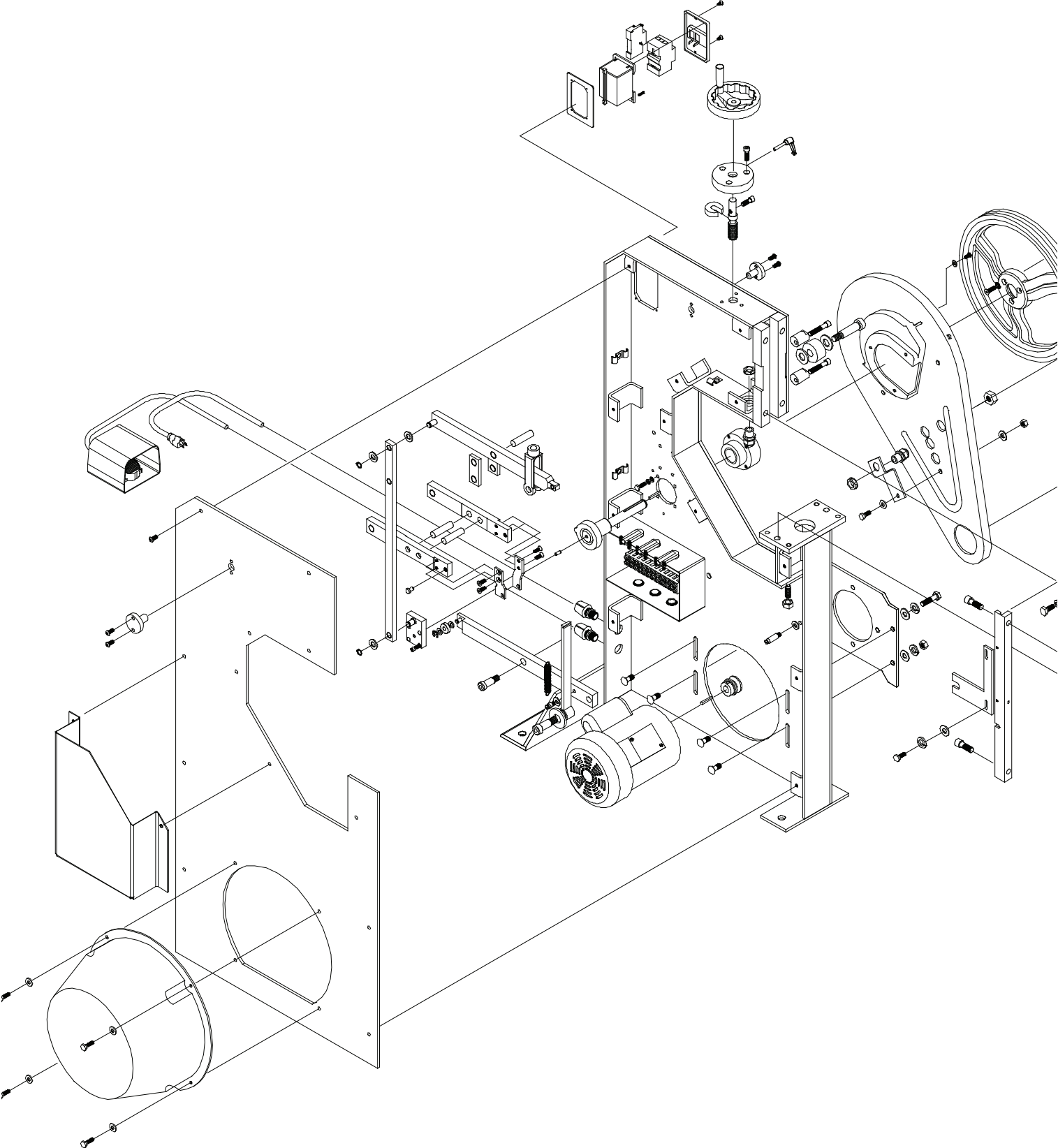

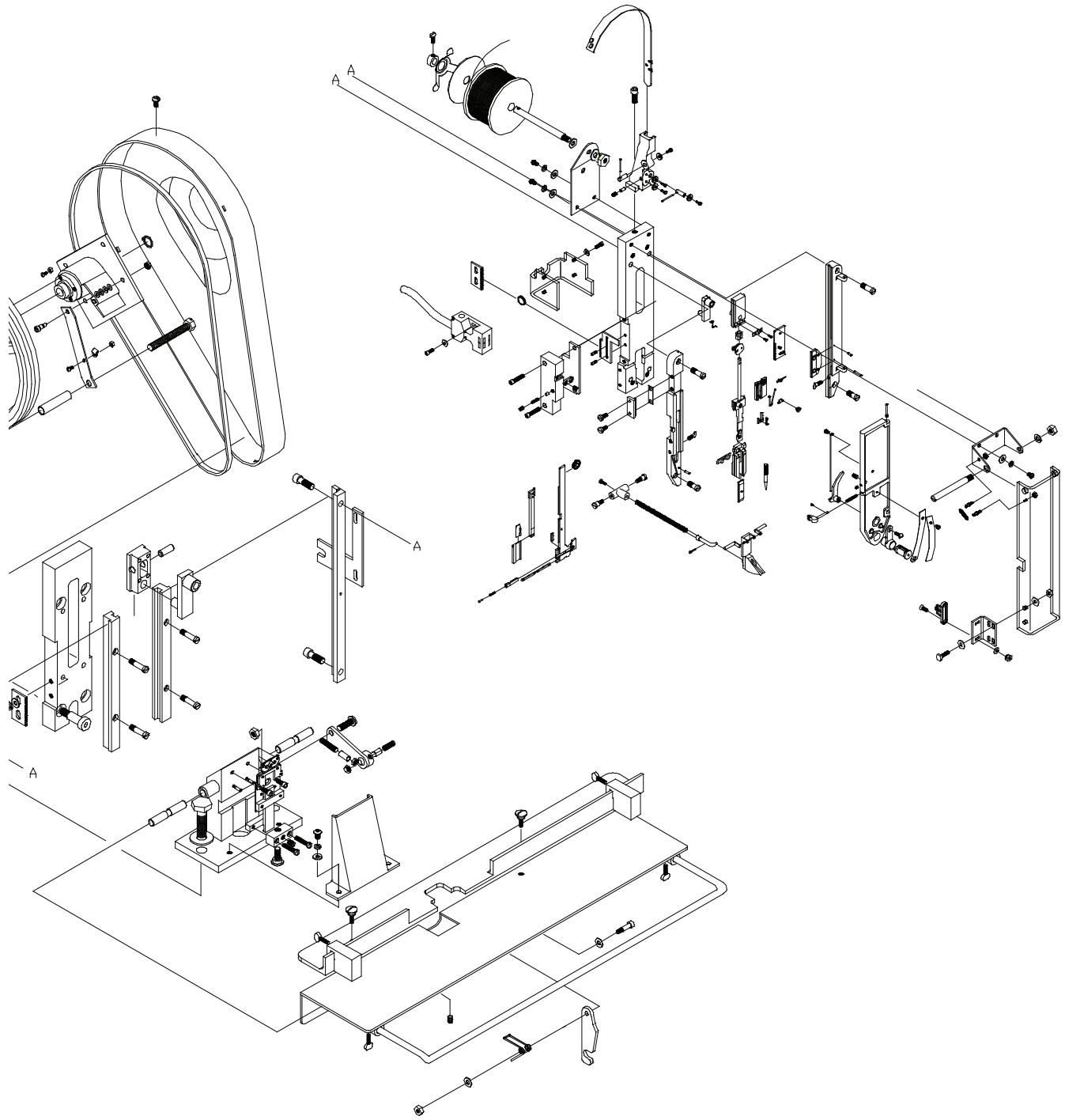

Head Mounting and Face Plate Assemblies

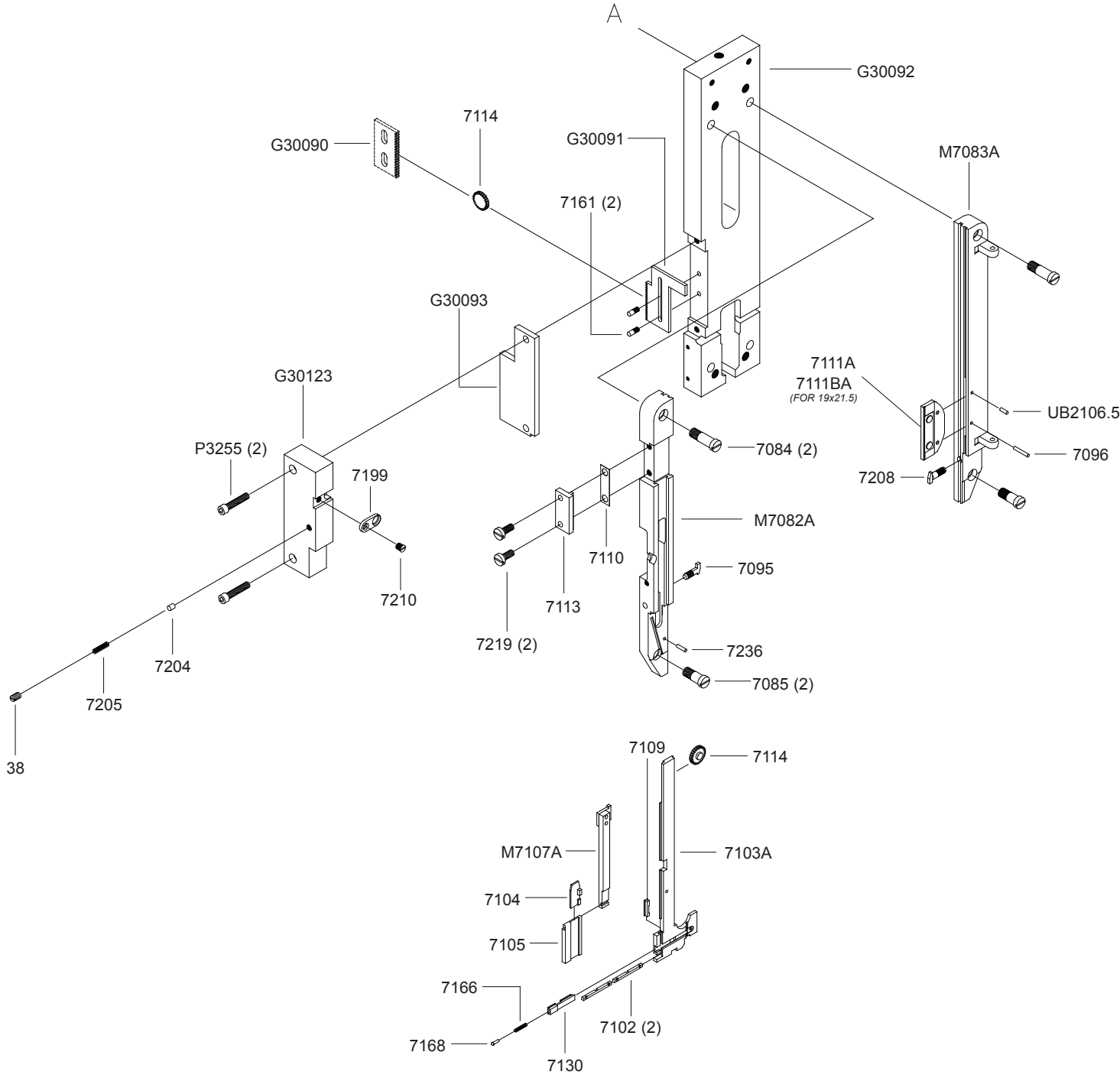

Head Mounting and Face Plate Assemblies

PART No.	DESCRIPTION	QUANTITY
G30090	Adjuster Rack	1
G30091	Adjuster Rack	1
G30092	Head Mounting Plate	1
G30093	Adjuster Rack Cover Plate	1
G30123	Face Plate Hinge Mount	1
M7082A	Face Plate Assembly - Left	1
M7083A	Face Plate Assembly - Right	1
M7107A	Wire Cutter Operating Slide Assembly	1
P3255	Screw 1/4 - 20 x 1-1/4	2
UB2106.5	Spring Pin 1/8x3/8	1
38	Clincher Slide Adjustment Screw	1
7084	Face Plate Screw - Upper	2
7085	Face Plate Screw - Lower	2
7095	Driver Bar Wedge - Left	1
7096	Driver Bar Pin - Right	1
7102	Wire Cutter	2
7103A	Wire Cutter Holder	1
7104	Wire Cutter Operating Slide Shoe	1
7105	Wire Cutter Operating Slide Wedge	1
7109	Wire Cutter Retainer	1
7110	Wire Feed Adjuster Rack Shim	
7111A	Wire Guide Assembly	1
7113	Wire Feed Adjustment Rack	1
7114	Wire Feed Adjusting Pinion	2
7130	Wire Holder Slide	1
7161	Swivel Operating Sector Pin	2
7166	Wire Holder Slide Spring	1
7168	Wire Holder Slide Pin	1
7199	Door Latch Catch	1
7204	W /C Operating Slide Friction Plug	1
7205	W /C Operating Slide Spring	1
7208	Driver Bar Wedge - Right	1
7210	Door Latch Screw	1
7219	Wire Adjuster Rack Screw	2

Driver and Supporter Assemblies

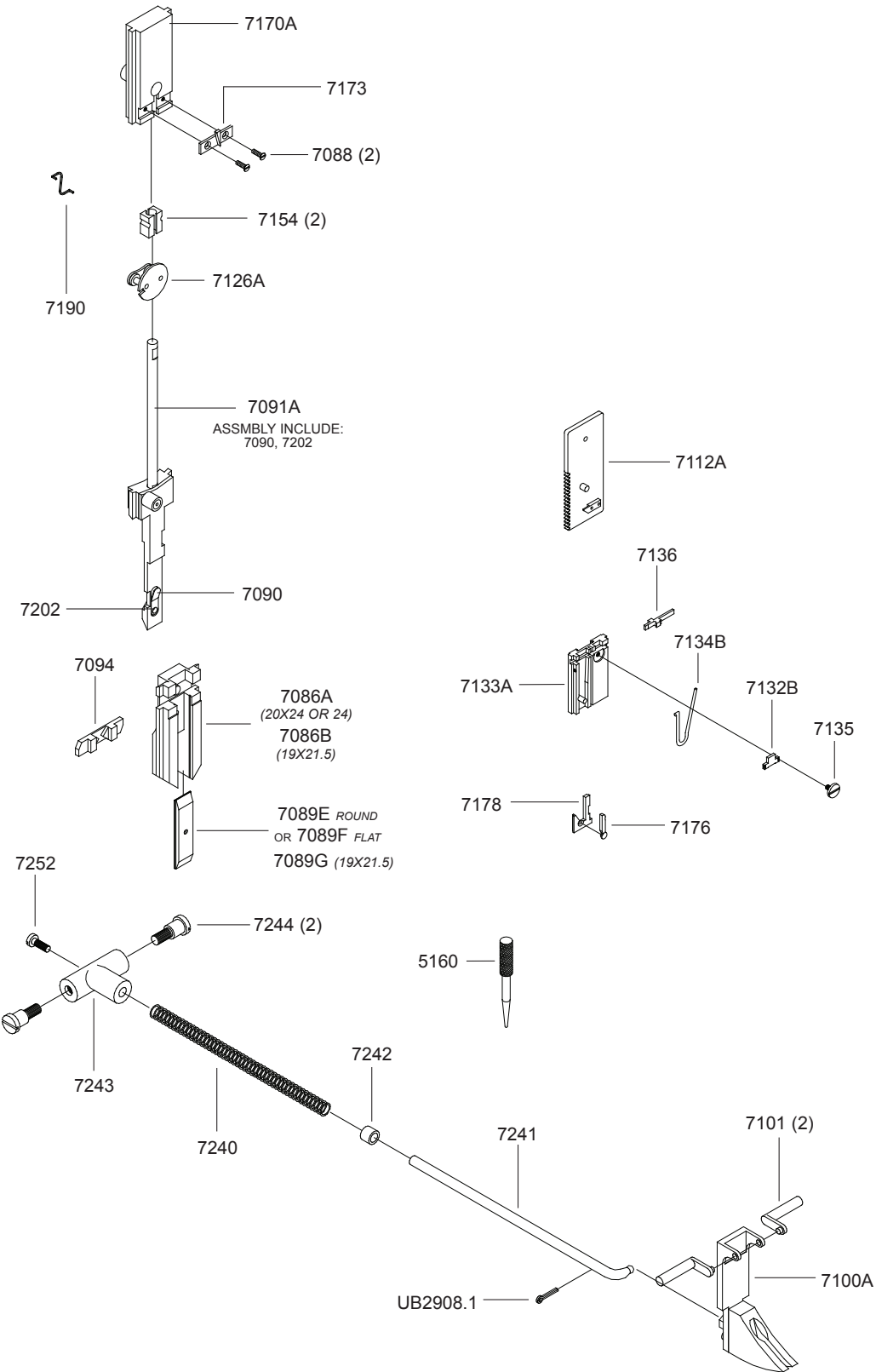

Driver and Supporter Assemblies

PART No.	DESCRIPTION	QUANTITY
UB2908.1	Supporter Spring Cotter Pin	1
5160	Driver Release Pin	1
7086A	Bender Bar Assembly	1
7086BA	Bender Bar Assembly (19x21.5)	1
7088	Driving Bar Screw	2
7089E	Driver - Round / Flat	1
7089F	Driver - Flat Wire	1
7089G	Driver - Flat Wire (19x21.5)	1
7090	Driver Spring	1
7091A	Driver Bar Assembly	1
7094	Driver Bar Latch	1
7100A	Supporter Assembly	1
7101	Supporter Crank	2
7112A	Wire Feed Slide Assembly	1
7126A	Feed Grip Assembly	1
7132B	Wire Grip - Fixed	1
7133A	Wire Grip Holder	1
7134B	Wire Grip Spring	1
7135	Wire Grip Spring Screw	1
7136	Wire Grip - Moveable	1
7154	Wire Feed Shoe	2
7170A	Upper Driving Bar	1
7173	Driving Bar Wedge	1
7176	Grip Operating Lever	1
7178	Grip Operating Lever Slide	1
7190	Wire Feed Shoe Spring	1
7202	RIVET	2
7240	Supporter Spring	1
7241	Supporter Spring Rod	1
7242	Supporter Spring Rod Collar	1
7243	Supporter Rod Guide	1
7244	Supporter Guide Stud	2
7252	Supporter Rod Screw	1

19x21-1/2 Flat Wire Conversion

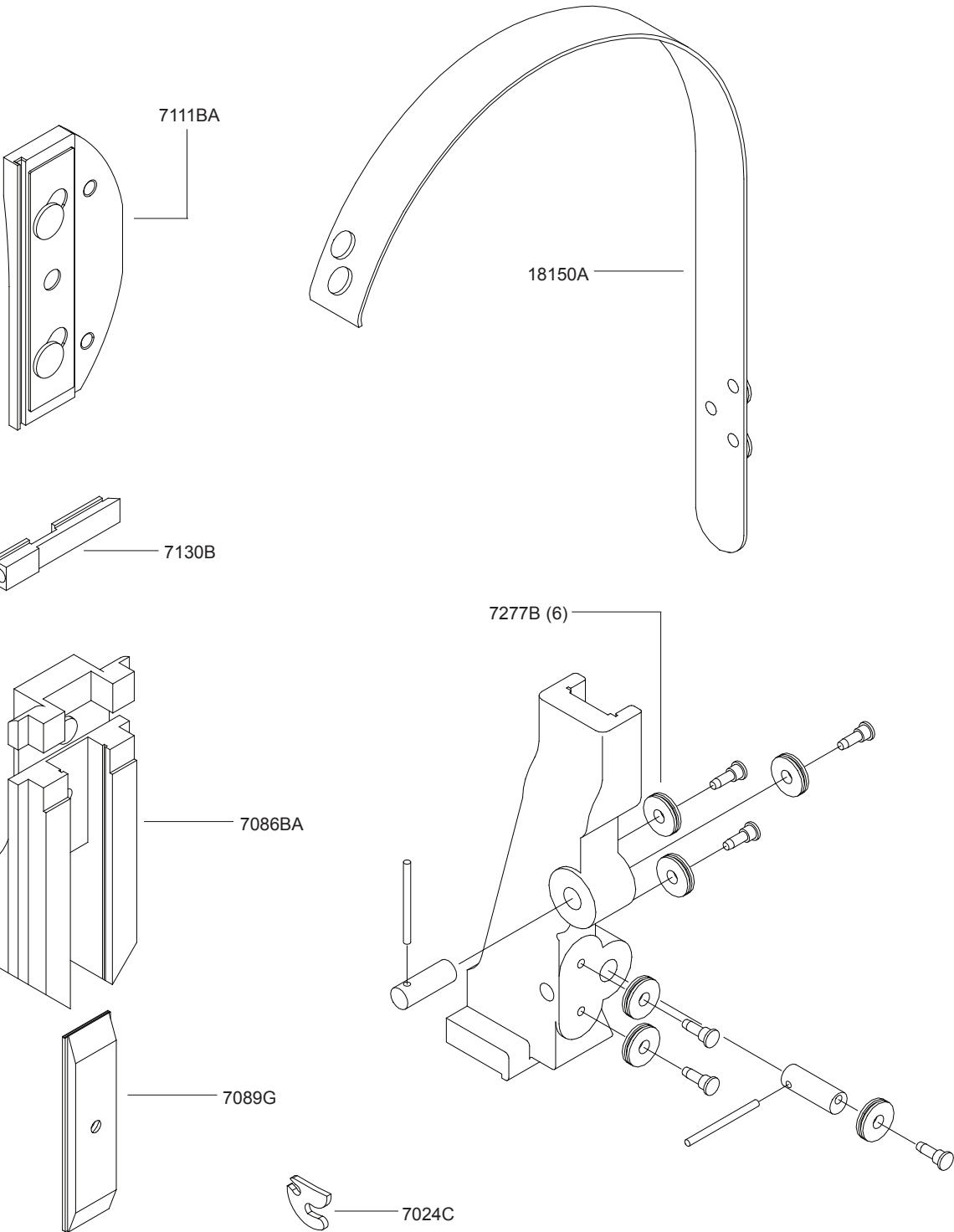

19x21-1/2 Flat Wire Conversion

PART No.	DESCRIPTION	QUANTITY
18150A	Wire Guide Spring	1
7024C	Clincher Point, Flat 19x21.5"	2
7086BA	Bender Bar Assembly 19x21.5	1
7089G	Driver 19x21-1/2	1
7111BA	Wire Guide 19x21-1/2	1
7130B	Wire Holder Slide	1
7277B	Wire Straightener Rollers	6

Door Assembly

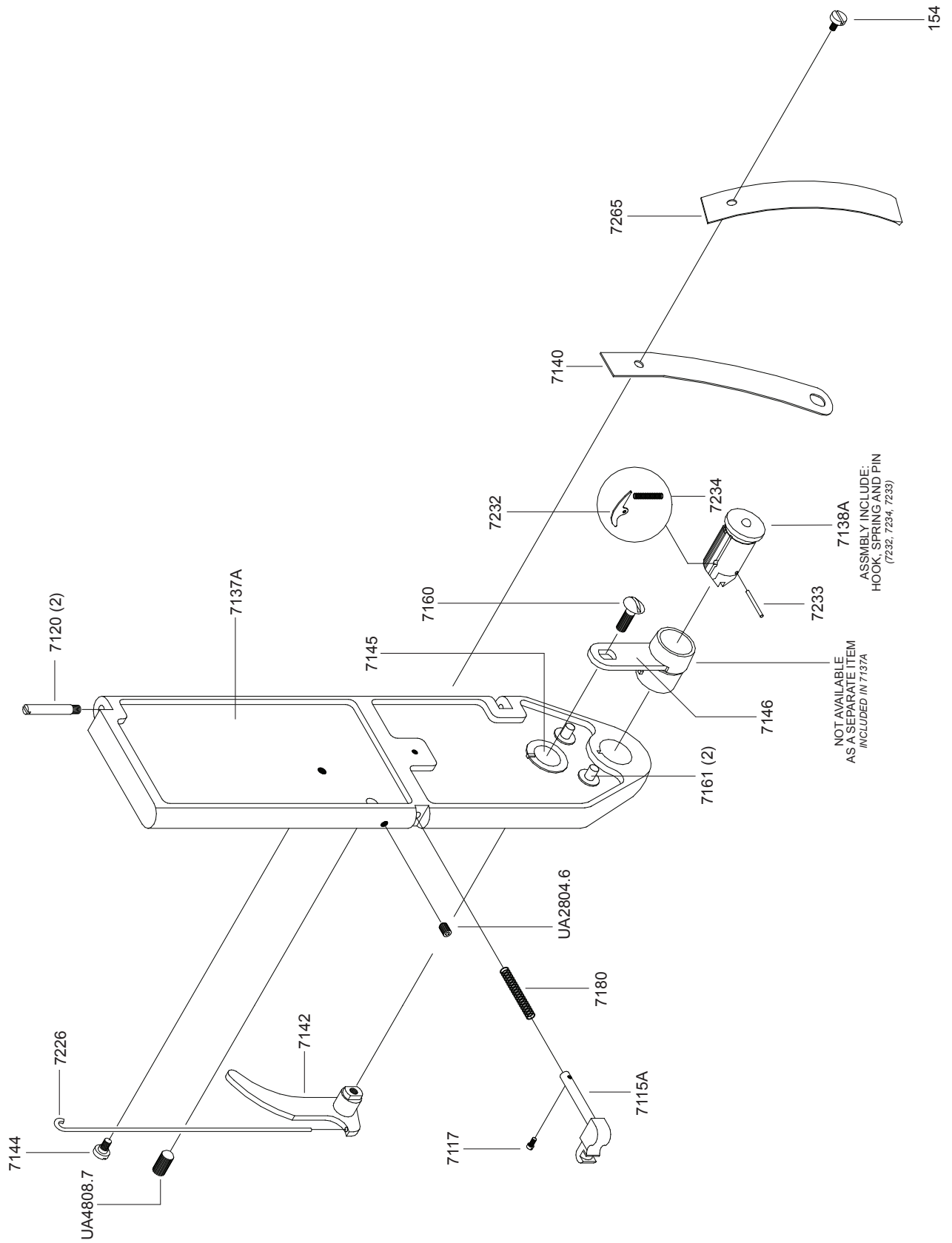

Door Assembly

PART No.	DESCRIPTION	QUANTITY
UA2804.6	Screw 8 - 32 x 1/4	1
UA4808.7	Set Screw, 1/4-28 X 1/2"	1
154	Swivel Spring Screw	1
7115A	Door Latch Assembly	1
7117	Door Latch Screw	1
7120	Door Hinge Screw	2
7137A	Door Assembly	1
7138A	Swivel Assembly	1
7140	Swivel Spring	1
7142	Swivel Operating Lever	1
7144	Swivel Operating Spring Screw	1
7145	Swivel Operating Lever Bushing	1
7146	Swivel Operating Lever Sector	1
7160	Swivel Operating Lever Screw	1
7161	Swivel Operating Sector Pin	2
7180	Tension Roller Spring	1
7226	Swivel Operating Lever Spring	1
7232	Swivel Hook	1
7233	Swivel Hook Pin	1
7234	Swivel Hook Spring	1
7265	Swivel Spring Strip	1

Part Number / Description Cross-Reference

ITEM NO.	DESCRIPTION	QUANTITY	ITEM NO.	DESCRIPTION	QUANTITY
15150LA	Wire Guide Spring	1	7120	Door Hinge Screw	2
154	Swivel Spring Screw	1	7126A	Feed Grip Assembly	1
18182	Clincher Slide	1	7130	Wire Holder Slide	1
18183	Clincher Slide Adj. Block	1	7130B	Wire Holder Slide	1
18184	Clincher Slide Block Clamp	1	7131	Wire Holder Block	1
18186	Clincher Slide Adj. Screw	1	7132B	Fixed Wire Grip	1
2024G5	Wire - Galvanized	1	7133A	Wire Grip Holder	1
2245	Spool Washer	1	7134B	Wire Grip Spring	1
29	Dowel	2	7135	Wire Grip Spring Screw	1
35	Clincher Slide Link Spring	1	7136	Moveable Wire Grip	1
36	Pin	1	7137A	Door Assembly	1
38	Set Screw, 1/4-28 x 3/8", Slotted	2	7138A	Swivel Assembly	1
406	Clincher Operating Lever Spring Screw	1	7140	Swivel Spring	1
425	Wire Guide Spring Holder Screw	4	7142	Swivel Operating Lever	1
5160	Driver Release Pin	1	7144	Swivel Operating Spring Screw	1
63	Work Guide Screw	2	7145	Swivel Operating Lever Bushing	1
7024B	Flat Clincher Point	2	7146	Swivel Operating Lever Sector	1
7024C	Flat Clincher Point (19x21.5)	2	7154	Wire Feed Shoe	2
7056	Work Table Extension	1	7160	Swivel Operating Lever Screw	1
7084	Upper Face Plate Screw	2	7161	Swivel Operating Sector Pin	2
7085	Lower Face Plate Screw	2	7166	Wire Holder Slide Spring	1
7086A	Bender Bar Assembly	1	7167	Wire Retainer	1
7086BA	Bender Bar Assembly (19x21.5)	1	7168	Wire Holder Slide Pin	1
7088	Driving Bar Screw	2	7169	Upper Driver Bar Pin	1
7089E	Round Wire Driver	1	7170A	Upper Driving Bar	1
7089F	Flat Wire Driver	1	7173	Driving Bar Wedge	1
7089G	Driver (19x21.5)	1	7176	Grip Operating Lever	1
7090	Driver Spring	1	7178	Grip Operating Lever Slide	1
7091A	Driver Bar Assembly	1	7180	Tension Roll Spring	1
7092	Driver Bar Block	1	7190	Wire Feed Shoe Spring	1
7093	Driver Bar Rod	1	7194	Swivel Operating Lever Cam Roller	1
7094	Driver Bar Latch	1	7195	Swivel Operating Cam Roll Stud	1
7096	Right Driver Bar Pin	1	7197	Wire Retainer Stud	2
7097A	Supporter	1	7199	Door Latch Catch	1
7100A	Supporter Assembly	1	7202	Driver Spring Rivet	1
7101	Supporter Crank	2	7204	Wire Cut. Oper. Slide Friction Plug	1
7102	Wire Cutter	2	7205	Wire Cutter Operating Slide Spring	1
7103A	Wire Cutter Holder	1	7207	Driver Bar Rivet	1
7104	Wire Cutter Operating Slide Shoe	1	7208	Right Driver Bar Wedge	1
7105	Wire Cutter Operating Slide Wedge	1	7210	Door Latch Screw	1
7109	Wire Cutter Retainer	1	7212	Wire Clip	1
7111A	Wire Guide Assembly	1	7214	Wire Feed Slide Stud	1
7111BA	Wire Guide Assy (19x21.5)	1	7217	Feed Plate operating Stud	1
7112A	Wire Feed Slide Assembly	1	7219	Wire Adjusting Rack Screw	2
7113	Wire Feed Adjusting Rack	1	7223	Driver Bar latch Friction Plug	1
7114	Wire Feed Adjusting Pinion	2	7224	Wire Cutter Friction Spring	1
7115A	Door Latch Pin Assembly	1	7226	Swivel Operating Lever Spring	1
7117	Door Latch Screw	1	7228	Bender Bar Rivet	1
7118	Door Hinge	2	7232	Swivel Hook	1

Part Number / Description Cross-Reference

PART NO.	DESCRIPTION	QUANTITY	PART NO.	DESCRIPTION	QUANTITY
7233	Swivel Hook Pin	1	850730B	V-Belt 3/8 x 61	1
7234	Swivel Hook Spring	1	850731	Pulley - AK15 - 5/8	1
7236	Left Driving Bar Pin	2	850732	Pulley - AK17 - 5/8	1
7240	Supporter Spring	1	850886	Retaining Ring	1
7241	Supporter Spring Rod	1	850888	Control Collar Assembly	1
7242	Supporter Spring Rod Collar	1	850889	Brake Spring	2
7243	Supporter Rod Guide	1	850890	Plate Assembly	1
7244	Supporter Guide Stud	2	850891	Output Assembly	1
7245	Supporter Screw	1	850892	Brake Hub	1
7252	Supporter Rod Screw	1	850962	Anti-Backup Spring	1
7253A	Clincher Plate 1/2	1	850991	Anti-Overung Spring	1
7256	Clincher Bottom Bar	1	850992	Actuator Assembly with Plunger	1
7257B	Round Clincher Point	2	850998	Coil Assembly - 230V/50Hz	1
7258	Clincher Pivot Stud	2	850999	Coil Assembly - 115V/60Hz	1
7259	Clincher Spacer Stud	2	851005	Strain Relief	2
7260	Clincher Slide Block Rivet	2	851126	Clutch Shim .005"	
7265	Swivel Spring Strip	1	85128	Connector	3
7277	Wire Straightener Roller	6	851321	Input Hub	1
7277B	Wire Straightener Roller	6	851742	Wire 90 Disconnect	5
7278	Wire Straightener Roll Stud	6	85982	Lock Nut	2
7281	Wire Str. Eccentric Friction Plug	2	86243	110V Power Cord	1
7282	Wire Straightener Eccentric	2	88038	Nylon Cable Clamp	2
7423	Left & Right Work Stop	2	9081	Screw	2
7645A	Table Support Bracket	1	FC9633	Key	1
7647	Table Support Bracket Stop	1	FC9656A	Clutch Anchor Assembly	1
7657	Table Support Bracket Block	1	G30002	Left Side Cover Plate	1
7659	Table Extender Bracket	2	G30006A	Bearing Housing Assembly	1
7675	Belt Guard	1	G30007B	Crank Shaft Assembly	1
7676	Belt Guard	1	G30011A	Adjuster Lever Assembly	2
7678B	Drive Pullet	1	G30013A	Drive Lever Assembly	1
7690	Tension Spring	1	G30014	Slide Pin	1
7691	Reamed Set Collar	1	G30015	Slider	1
7693	Spool Stud	1	G30017A	Pivot Link Assembly	2
850300A	115V Wired Motor 1/2 HP	1	G30020A	Upright Link Assembly	1
850300B	230V Wired Motor 1/2 HP	1	G30028	Slider Guide	2
850303B	Terminal Strip	1	G30029	Slider Guide Screws	4
850307	Power Cord - 220V	1	G30031B	Adjuster Fork	2
850313	Foot Switch Guard	1	G30037A	Clincher Upright Link Assembly	1
850314	Strain Relief	3	G30041B	Clincher Roller Assembly	1
850315	Strain Relief Nut	2	G30043A	Clincher Lever Assembly	1
850316	RFI Filter, AC Noice	1	G30044A	Table/Clinch Mounting Assembly	1
850317	Clutch Cable	1	G30048	Motor Mounting Plate	1
850318	Wire Footswitch	1	G30049	Dowel Pin 5/8x2-1/2	3
850319	Wire Safety Switch	1	G30050	Bearing 3/8x1/2	1
850320	115V Starter Assembly 1/2 HP	1	G30053	Screw 5/8x1	4
850321	Starter Assy 1/2 HP, 230V	1	G30054	Bearing 5/8x3/4	1
850337	Wire Terminal Ring	1	G30055	Bearing 3/4x1	1
850677	Wrap Spring Clutch 115V	1	G30056	Bearing 5/8x1/4	2
850678	Wrap Spring Clutch 230V	1	G30061	Screw 1/2x1-1/2	1

Part Number / Description Cross-Reference

PART NO.	DESCRIPTION	QUANTITY	PART NO.	DESCRIPTION	QUANTITY
G30062	Bearing 1.25 ID	2	HN51618	Hex Nut	1
G30063	Screw 5/8 x 1	1	HN51618.2	Hex Jam Nut 5/16-18	1
G30064	Screw 3/4x1-1/4	1	K1033	Complete Table Assembly	1
G30065	Screw 1/2x1	4	KN1032	Kep Nut 10-32	2
G30067	Bolt 3/8-16x1	4	LW10	Lock Washer #10	4
G30074	Driver Lever Pin	1	LW14	Lock Washer 1/4	10
G30087	Face Plate Head Adapter	1	LW38	Lock Washer 3/8	9
G30088B	Left Head Guide Plate	1	M11009	Plastic Washer	1
G30089B	Right Head Guide Plate	1	M7082A	Left Face Plate Assembly	1
G30090	Adjuster Rack	1	M7083A	Right Face Plate Assembly	1
G30091	Adjuster Rack	1	M7107A	Wire Cutter Operating Slide Assy	1
G30092	Head Mounting Plate	1	M7201B	Work Guide	1
G30093	Adjuster Rack Cover Plate	1	M7321A	Wire Straightener	1
G30094	Supporter Spring Bracket	1	P2582	Connector 3/8x90 Deg	3
G30096	Drive Link	1	P2731	Thumb Screw 1/4-20x3/4	1
G30097	Adjuster Pivot Pin	2	P3255	Screw 1/4-20x1-1/4	2
G30099B	Adjuster Crank Housing	1	P7507	Screw 1/4-20x3/4	10
G30100B	Adjuster Crank Shaft Insert	1	P7863	Retaining Ring	1
G30101B	Adjuster Yoke	1	P8054	Retaining Ring 5100-50	2
G30102B	Adjuster Shaft Screw	1	PG10202	Tension Spring	1
G30103	Adjuster Stop	2	PG10203	Screw	2
G30113	Clincher Guard	1	PG10233	Adhesive Wire Clamps	10
G30116A	Crank Throw Assembly	1	PG10255	Screw 1/4-20x5/8	4
G30117	Motor Cover	1	PG10271	Spool Friction Washer	1
G30118	Belt Guard Bracket	1	PW10	Washer #10	3
G30119	Adjuster Spool	1	PW10.3	Washer 3/16	11
G30120	Wire Spool Bracket	1	PW10.6	Washer #10	4
G30121	Head Guard	1	PW12	Washer Zinc 1/2	1
G30122	Guard Mounting Bracket	1	PW12.1	Washer Black 1/2	2
G30123	Face Plate Hinge Mount	1	PW12.3	Washer Zinc 1/2 SAE	3
G30124	Actuator Key Bracket	1	PW12.4	Washer Black 1/2 SAE	2
G30125	Head Guard Pivot	1	PW14	Washer 1/4	14
G30126	Fixed head Guard	1	PW14.2	Washer Zinc	4
G30127	Starter Mounting Flange	1	PW14.6	Washer	4
G30128	Hand Wheel	1	PW38	Washer 3/8	8
G30130	Adjuster Stud	1	PW516	Washer 5/16	4
G30159	Screw 1/2-20x1-1/4	2	SW14.1	Washer	3
G30160	Screw 1/4-20x7/8	4	UA1428.1	Screw 1/4-28x1/4	1
G30163	Self Tap Screw 10x3/8	1	UA2804.6	Screw 8-32x1/4	1
G30175	Adjuster Crank	1	UA3216.4	Screw 10-32x7/8	2
G30176	Screw M4x0.7x25	2	UA3304.2	Screw 10 - 32 x 1/4	2
G30178	Retaining Ring	1	UA3410.4	Screw, 10-32x5/8 SFHCS	2
HN1032	Nut 10-32	2	UA3806.16	Screw 1/4-20x3/8	6
HN1213.2	Nut 1/2-13	1	UA3806.2	Screw 10-32x3/8	1
HN1420	Nut 1/4-20	6	UA3806.3	Screw 10-32x3/8	4
HN1420.2	Hex Jam Nut 1/4-20	2	UA3806.9	Screw 10-32x3/8	3
HN1420.5	Hex Nut 1/4-20	4	UA3808.1	Screw 10-32x1/2	2
HN3816	Hex Nut 3/8-16	5	UA3808.2	Screw	4
HN440.4	Hex Nut 4-40 Zinc	4	UA3814	Screw 10-32x7/8	2

Part Number / Description Cross-Reference

PART NO.	DESCRIPTION	QUANTITY
UA4060	Screw 1/4 - 28x1/4	1
UA4108.1	Screw 1/4-20x1/2	6
UA4110.1	Screw 1/4-20x5/8	4
UA4808.3	Clincher Block Screw	1
UA4808.7	Set Screw, 1/4-28 X 1/2", SH	1
UA4810.1	Screw 1/4-20x5/8	7
UA4810.5	Screw 1/4-20x5/8	14
UA4812.1	Screw 1/4-20x3/4	4
UA4812.7	Screw 1/4-20x3/4	3
UA4816.1	Screw 1/4-20x1	2
UA4820.3	Screw 1/4-20x1-1/4	1
UA4828.3	Screw 1/4-20x1-1/4	1
UA5112.1	Screw 5/16-18x3/4	1
UA5116.1	Screw 5/16-18x1	1
UA5120.2	Screw 5/16-18x1-1/4	1
UA6110.1	Screw 3/8-16x5/8	4
UA6116.1	Screw 3/8-16x1	4
UA6812.1	Screw 3/8-16x3/4	4
UA6816.2	Screw 3/8-16x1	1
UB2106.5	Spring Pin 1/8x3/8	1
UB2908.1	Supporter Spring Cotter Pin	1
UB3912.2	Spirol Pin	2

Wiring Diagram

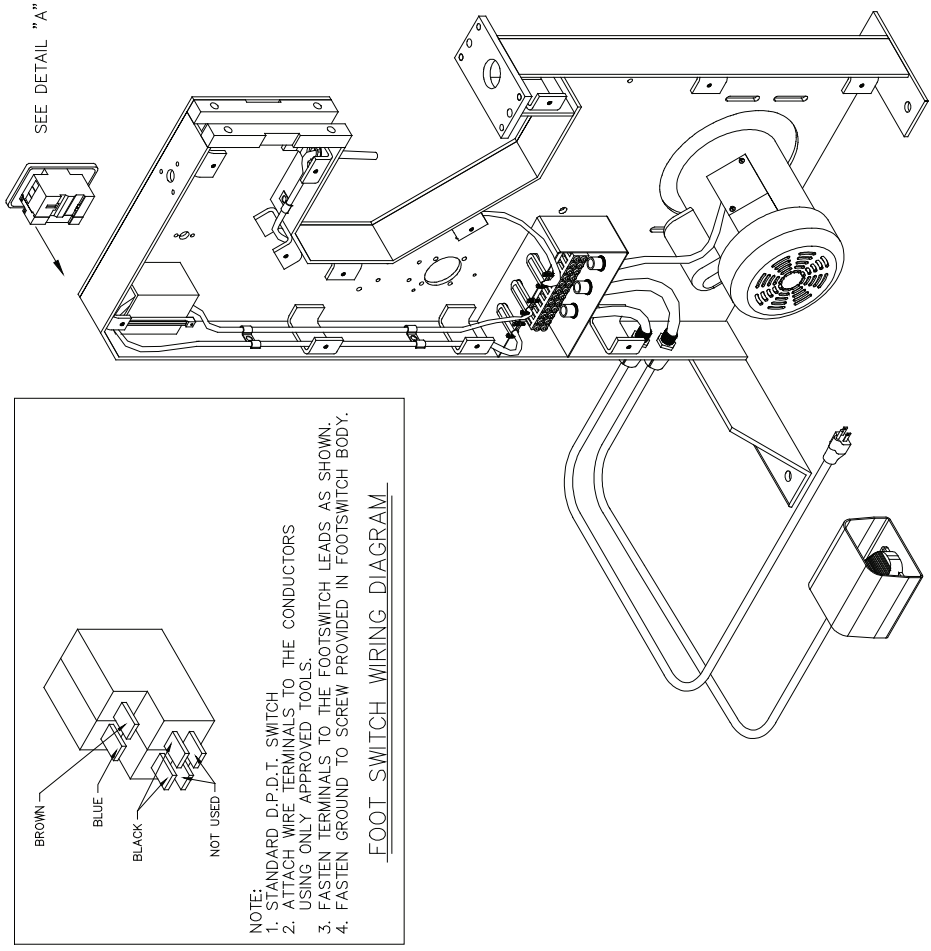
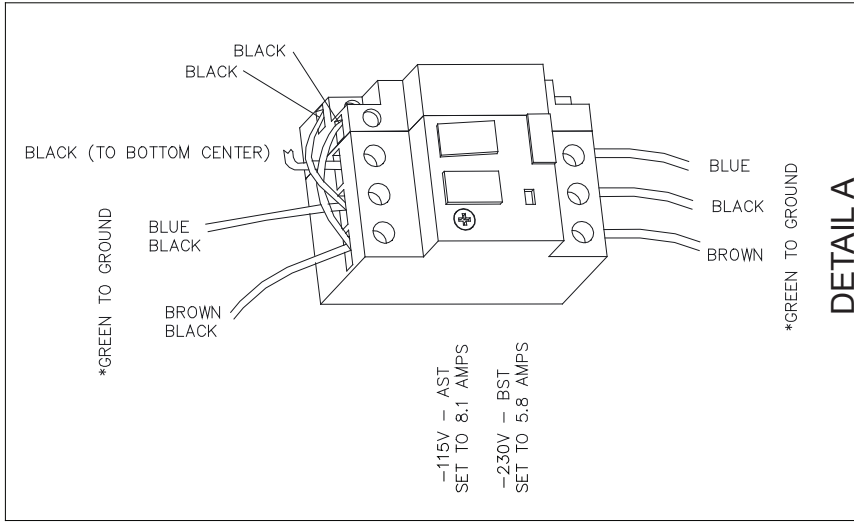

Complete Wiring with Detail

Wiring Diagram

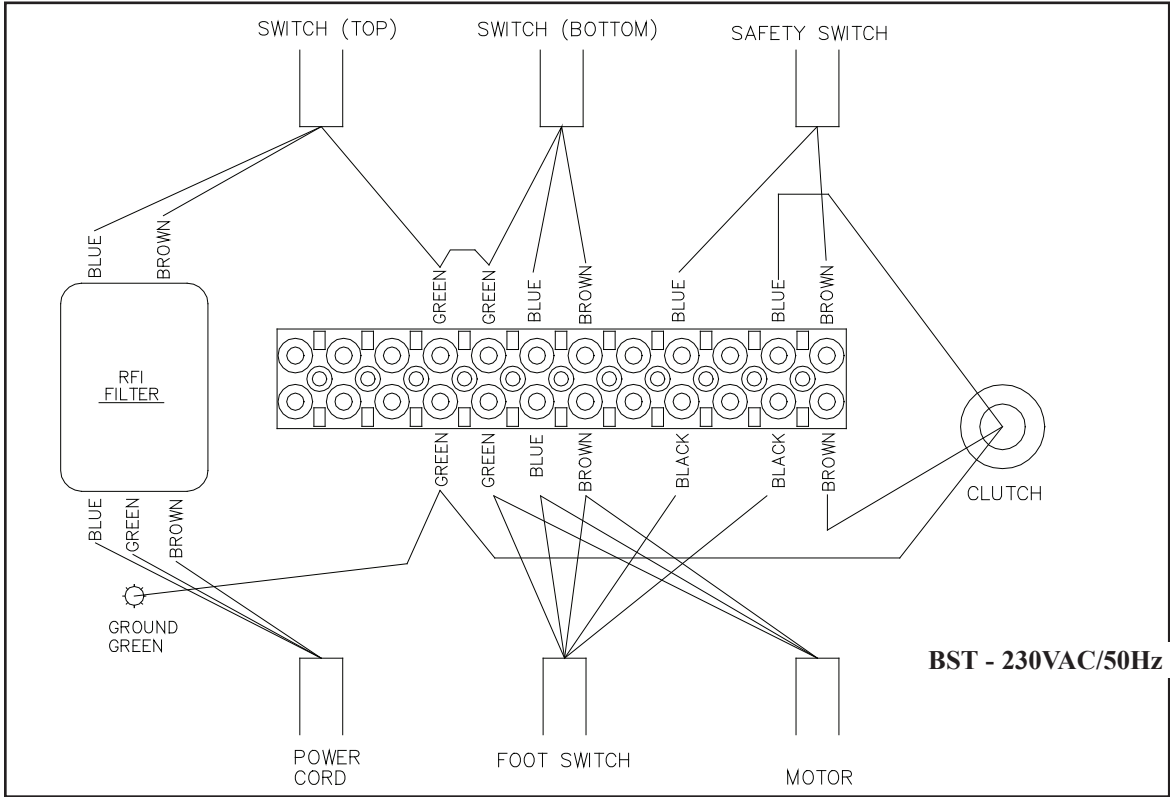
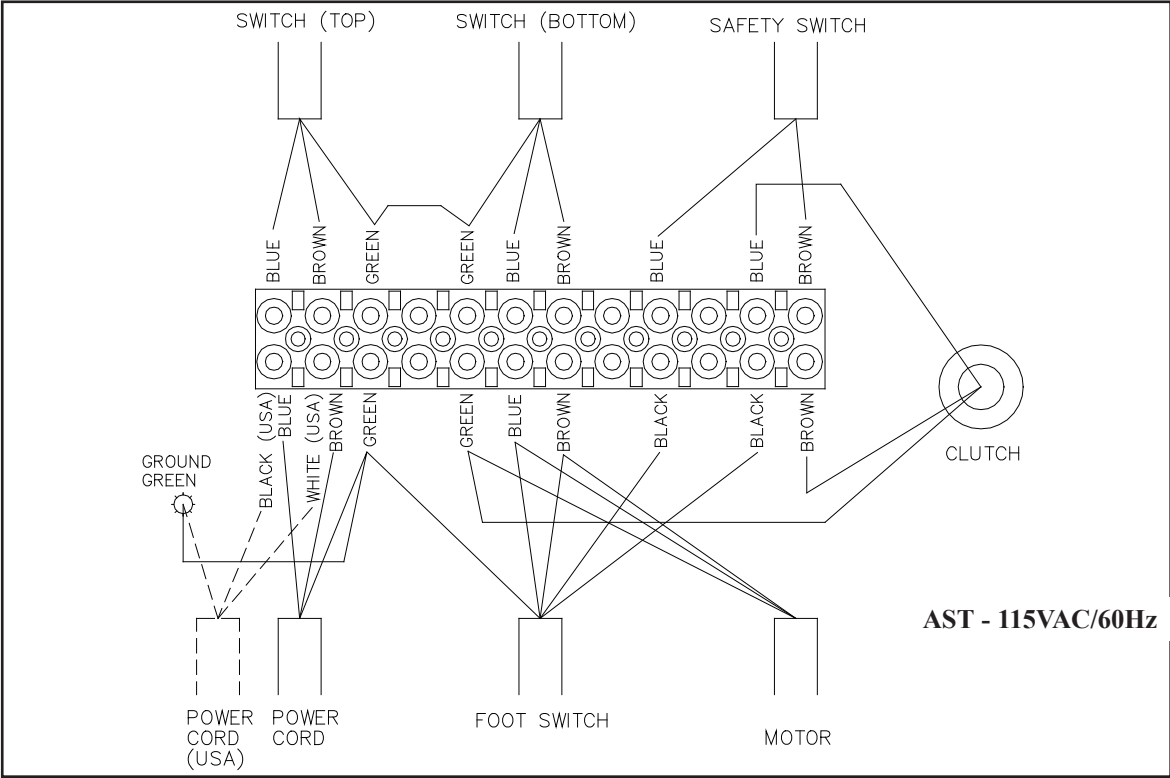

REGISTRATION

To better service your wire stitching needs, please take a moment to fill out and return this registration card.

Please take a moment to fill out the attached card and mail it to DeLuxe Stitcher Company, Inc. In addition, duplicate the information for your records to assist when making further inquiries.

CUSTOMER

Name : _____
(First) _____ (Middle Initial) _____ (Last) _____
Company : _____
Street Address : _____
City : _____ State/Province : _____ Zip : _____
Country : _____
Phone : _____ Fax : _____ E-mail : _____

PRODUCT

Machine(s) Purchased : _____
Serial Number(s) : _____
With Head(s) : _____
(Type/Quantity Purchased) _____
Serial Number(s) : _____
Head(s) Purchased : _____
Serial Number(s) : _____

DEALER

Date Received : _____
Dealer Name : _____
Dealer Street Address : _____
City : _____ State/Province : _____ Zip : _____
Country : _____
Dealer Phone : _____
Other Bindery Products Used : _____

PRODUCT

Machine(s) Purchased : _____
Serial Number(s) : _____
With Head(s) : _____
(Type/Quantity Purchased) _____
Serial Number(s) : _____
Head(s) Purchased : _____
Serial Number(s) : _____

DELUXE STITCHER GRAPHIC ARTS REPRESENTATIVE

Date Received : _____
Dealer Name : _____
Dealer Street Address : _____
City : _____ State/Province : _____ Zip : _____
Country : _____
Dealer Phone : _____

Would you like information sent to you about new products that would benefit your company? Yes No

Common Replacement Parts

Below is a list of the most common wear/replacement parts for the M7 Stitcher. This guide should help you when ordering replacement parts. If the part you need is not listed below, please refer to the more detailed parts list on pages 46-48 in this manual.

Description	Item Number
Clincher Points	7024B
Driver - Standard or Flat	7089E
Driver Spring	7090
Driver Bar Latch	7094
Wire Cutter	7102
Fixed Wire Grip	7132B
Wire Grip Spring	7134B
Wire Grip Spring Screw	7135
Moveable Wire Grip	7136
Swivel Operating Lever Sector	7146
Wire Feed Shoe	7154
Grip Operating Lever	7176
Grip Operating Lever Slide	7178
Wire Feed Shoe Spring	7190
Rivet	7202
Swivel Hook	7232
Swivel Hook Pin	7233
Swivel Hook Spring	7234
Clincher Point 1/2 - Round	7257B

**PLACE
STAMP
HERE**

**DELUXE STITCHER
COMPANY, INC.**
6635 West Irving Park Road
Chicago, Illinois 60634-2410 U.S.A.
Attn: Customer Service

LIMITED WARRANTY

DeLuxe Stitcher Company, Inc. warrants to the original retail purchaser that this product is free from defects in material and workmanship and agrees to repair or replace, at DeLuxe Stitcher's option, any defective product within 90 days from the date of purchase. This warranty is not transferable. It covers damage resulting only from defects in material or workmanship and does not cover conditions or malfunctions resulting from normal wear, neglect, abuse or accident.

This warranty is in lieu of all other express warranties. Any warranty of merchantability or fitness for a particular purpose is limited to the duration of this warranty. DeLuxe Stitcher shall not be liable for any incidental or consequential damages.

Some states do not allow limitations on how long an implied warranty lasts, or the exclusion or limitation of incidental or consequential damages, so the above limitations or exclusions may not apply to you. This warranty gives you specific legal rights and you may also have other rights which vary from state to state.

To obtain warranty service you must return the product, at your expense, together with proof of purchase to an authorized DeLuxe Stitcher Company Graphic Arts Dealer.

Always use genuine DeLuxe Stitcher parts. When ordering parts, please identify the part number, the part name, the wire size and crown size of your Stitcher.

DeLuxe Stitcher Company, Inc.
Chicago, Illinois 60634-2410
Phone: 773-777-6500 800-634-0810
Fax: 773-777-0156 800-417-9251
E-mail: info@deluxestitcher.com
Web Site: <http://www.deluxestitcher.com>



Declaration of Conformity

We, *DeLuxe Stitcher Company*

6635 West Irving Park Road
Chicago, Illinois 60634-2410 U.S.A
Telephone 773-777-6500
Facsimile 773-777-0156

hereby declare under our sole responsibility that the

M7-BST *Stitching / Stapling Machines*

to which this declaration relates is in conformity with the
following European product safety directives:

Machinery Safety Directive

(89/392/EEC and amendments
91/368/EEC, 93/44/EEC, 93/68/EEC)

Electromagnetic Compatibility Directive

(89/336/EEC and amendments
91/C162/08, 92/31/EEC, 93/68/EEC)

as is verified by compliance with the following standards:

EN 60204-1:1992	prEN 894-1:1992	prEN 953:1992
EN 294:1992	prEN 894-3:1992	EN 55014:1193
prEN 614-1:1991	prEN 1050:1993	EN 55104:1995

Executed for *DeLuxe Stitcher Company*

this first day of January in the year 2009

By Frank P. Cangelosi Signature Frank P. Cangelosi

Title President



