

DELUXE STITCHER

C O M P A N Y I N C .

Machine Model : _____ Serial Number : _____

Head Serial Number : _____

Date Purchased/Installed : _____

StitchMaster

OPERATION AND MAINTENANCE MANUAL

SM-A25.....StitchMaster....115 V....25 Wire

SM-CE25..StitchMaster...230 V....25 Wire

(with Stitcher Head 2001ASMHD251/2)

SM-A2125.....StitchMaster....115 V....21x25 Wire

SM-CE2125....StitchMaster....230 V....21x25 Wire

(with Stitcher Head 2001ASMHD21251/2)

Before using this Stitcher, all operators must study this manual and follow the safety warnings and instructions. Keep these instructions with the Stitcher for future reference. If you have any questions, contact your local DeLuxe Stitcher Representative or Distributor.

WARNING!

StitchMaster

Machine operators and others in the work area should always wear safety glasses to prevent serious eye injury from fasteners and flying debris when loading, operating, or unloading this machine.

Do not operate this stitcher without all guards in place. The stitcher will not operate without the front guard closed properly. Do not modify the guards in any way. Always disconnect the power supply before removing any guards for servicing.

Never operate the machine with wire feeding through the head unless there is stock above the clinchers, otherwise serious damage may result.

Always turn power off when making adjustments. Always disconnect the power cord before any disassembly work.

Table of Contents

Introduction	4
Specifications	5
Installation	6
Pre-Inspection	6
Inspection	6
Mounting	6
Assembly	7
Operation	9
Wire Threading	9
Wire Straightening	9
Adjustments and Settings	11
Stitching Process	14
Saddle vs. Flat Stitching	14
Stops	15
Trip Modes	16
Troubleshooting	17
Maintenance	18
Lubrication	18
Cleaning	19
How to Order Spare Parts	20
Replacing Spare Parts	20
Modifications	24
Clincher Arm Adjustment	24
Timing	26
Appendices	27
Exploded Drawings	27
Wiring Schematic.....	37
Part Number/Description Cross Reference.....	38
Optional Equipment.....	41
Registration Card	44
Wear/Replacement Parts	45
Warranty	46
Declaration of Conformity.....	47

Introduction

The DeLuxe Stitcher StitchMaster is the Graphic Arts Industry's premier, portable, high-quality stitcher. It is quiet, fast and very dependable, in addition to being affordable. The StitchMaster is constructed in such a way that two machines may be mounted side-by-side to effectively create a dual-head stitcher at a cost considerably below that of a traditional multi-head stitcher.

There are two StitchMaster models; the SM-A which operates on 115VAC and the SM-CE which operates on 230VAC and conforms to all pertinent CE standards. All other performance characteristics of both models are the same.

The StitchMaster comes standard with parts for 25 gauge or smaller round wire. However, any StitchMaster can be modified to accommodate the following wire sizes: 23 or 24 gauge round or 21 x 25 flat.

The StitchMaster has a capacity from two sheets up to 1/4" (6.4mm), or sixty sheets of 20 pound bond paper. It accommodates both Flat and Saddle stitching. The StitchMaster has side stops which are easily adjusted from 2.5" to 26" wide. There are also pop-up pins for convenient corner stitching. In addition, the StitchMaster has movable clinchers for a tight stitch and one knob adjustment for both work thickness and centering the stitch.

The Stitchmaster has a rear contact trip and a foot switch for easy operation and single or continuous stitch modes can be accomplished at the touch of a button. It can clamp either to your own work table or to a heavy duty floor stand, which adjusts vertically from 28" to 42". The stand is an optional piece of equipment which can be purchased through your DeLuxe Stitcher Graphic Arts Representative. The StitchMaster can be plugged into any standard wall outlet.

The StitchMaster has a 5" (12.7 cm) throat depth for flat or horizontal stitching and a depth of 9" (22.9 cm) for saddle stitching. The heavy-duty work table is 16" (40.6 cm) wide and adjusts easily for flat or saddle work. The overall height combined is 24" (61.0 cm), the depth is 15" (38.1 cm) and the width is 16" (40.6 cm) with the table and 4" (10.2 cm) without the table.

For either the SM-A or the SM-CE, the machine itself weighs 28 lbs. (12.7 kgs.). The shipping weight including the wire spool, foot switch and tables is 50 lbs. (22.7 kgs.).

Specifications

Weight

Shipping Weight	50 lbs (22.7 kg)
StitchMaster Machine Unit	
SM-A25	28 lbs. (12.7 kgs)
SM-CE25	28 lbs. (12.7 kgs)
Wire Spool	5 lbs. (2.3 kgs)
Foot Switch	4.5 lbs. (2.0 kgs)
Tables	4.7 lbs. (2.1 kgs)

Physical Dimensions

Height	24" (61.0 cm)
Width	
With Tables	16" (40.6 cm)
Without Tables	4" (10.2 cm)
Depth	15" (38.1 cm)

Stitching Capacity Two Sheets to 1/4" (6.4 mm)

Wire Types 23 through 28 round or 21 x 25 flat
(25 gauge round standard)

Throat Depths

Flat (Horizontal)	5" (12.7 cm)
Saddle (Diagonal)	9" (22.9 cm)

Side Stops 2" - 14" (5.1 - 35.6 cm)

Power Requirements

SM-A	115VAC 50/60 Hz
SM-C.E.	230VAC 50/60 Hz

Minimum Recommended Circuit Capacity

SM-A	1.0 A
SM-C.E.	0.7 A

Installation

Pre-Inspection

Carefully inspect the condition of the shipping container before unpacking your StitchMaster. If the container is broken or damaged and there is evidence that the machine may be damaged, immediately notify the carrier who delivered the stitcher and the DeLuxe Stitcher Graphic Arts Representative from whom the machine was purchased.

Inspection

As you carefully unpack the machine, check to make sure all components were delivered and are in good working order. Use **Figure 2** in this manual for reference to the following pieces:

- StitchMaster complete with 26-style Head and manual
- Foot Switch with a Guard and Cord (PG10230)
- Wire Spool (25G5 or 2125G5 - optional) on a Spool Shaft (MG10110)
- Spool Cradle (MG10113)
- Trip Switch Assembly (MG10106A)
- Wire Guide Spring (MG10009A)
- Front Table (MG10083A) with Side Stop Rod Guides (PG10081 and PG10082) and Self Lock Pins (PG10242)
- Rear Table (MG10091A)
- Driver Release Pin (5160)
- 1/8" Hex Key Wrench (PG10293)
- Stitch samples

Note: Check the nameplate on the back of the stitcher to verify the operating voltage meets your requirements.

Mounting (Figure1)

You may mount the StitchMaster by clamping it to a secure work-table or to a StitchMaster Floor Stand (an optional purchase) as shown. Make sure that the table you choose is sturdy and heavy enough to support the weight of the StitchMaster. Tables which are not suitable will have a tendency to tip forward onto the operator. Place the machine where the operator will have sufficient light and working space. Make sure the Clincher Arm Knob (P3793) is turned tightly to secure the Machine to the work surface.

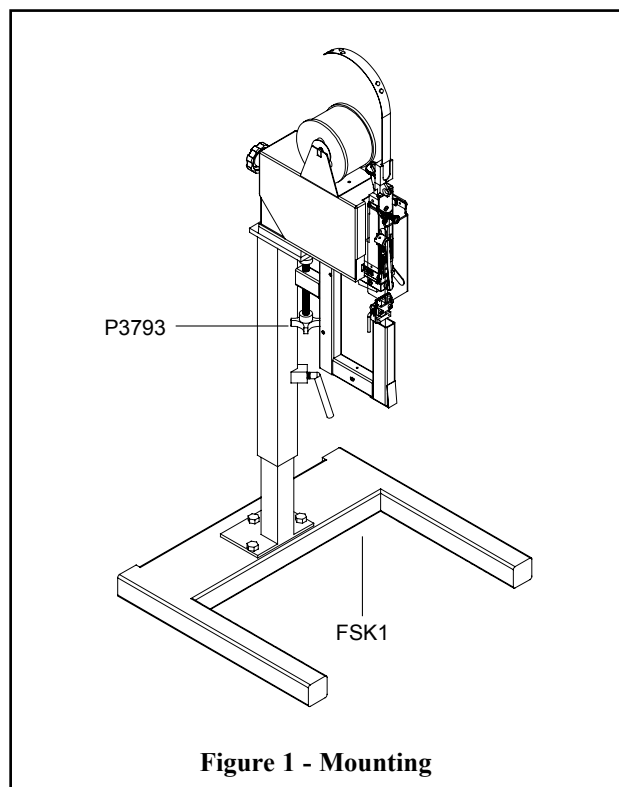
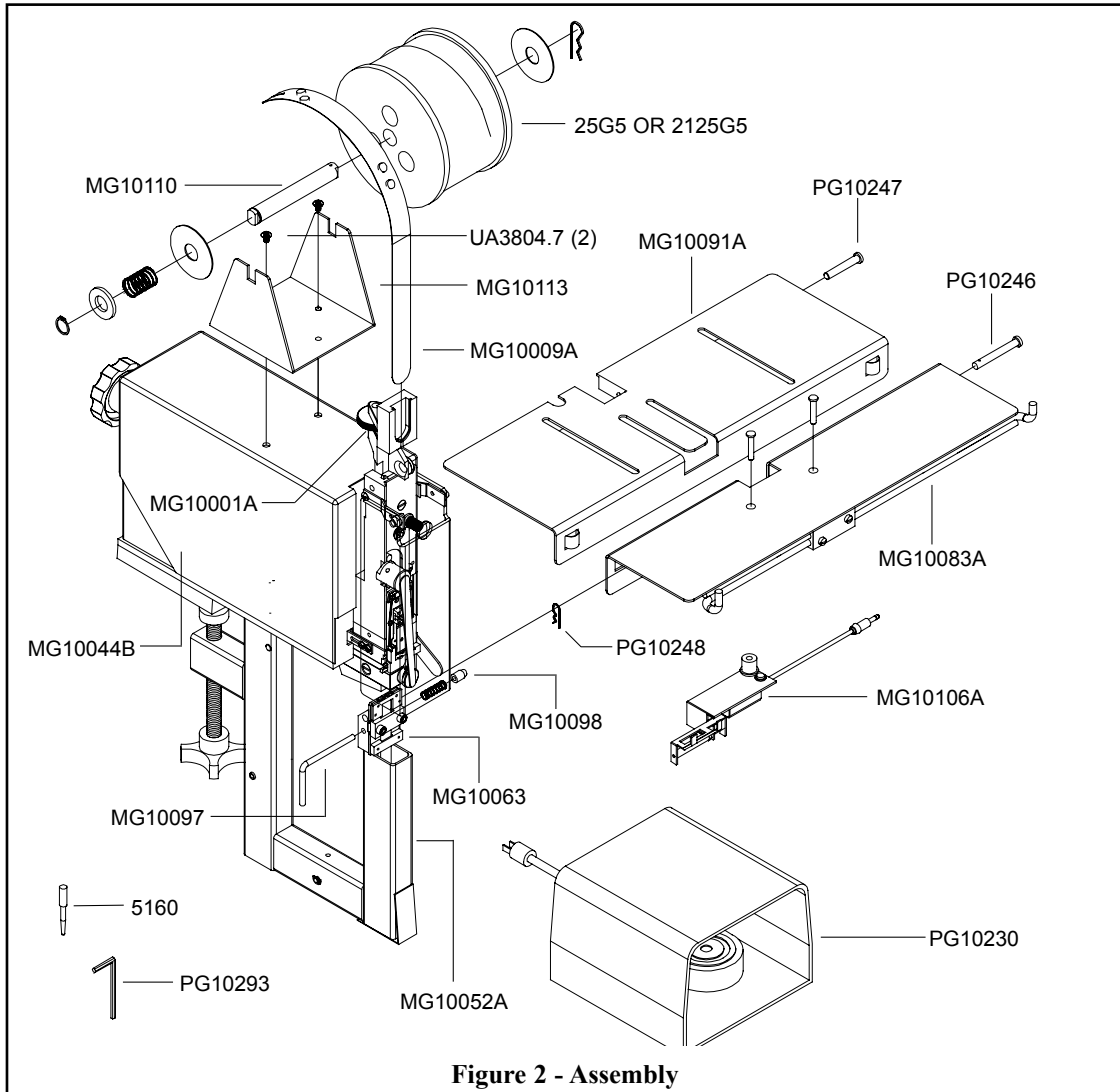

Figure 1 - Mounting

Assembly (Figure 2)



Always disconnect the power cord before assembling the StitchMaster or making any adjustments.

CAUTION

Assemble the components of the StitchMaster as needed. Use **Figure 2** for part number reference. The Wire Spool Cradle (MG10113) mounts with the two (2) screws (UA3804.7) on the top of the cover (MG10044B). Use the supplied 1/8" Hex Key Wrench (PG10293) to remove the screws and then secure the Cradle to the Cover. The Wire Spool (25G5 or 2125G5) comes assembled on the Spool Shaft (MG10110) which slips into the slots in the cradle. Pay attention to the payoff direction of the wire, see **Figure 2**, so that it matches the above drawing.

The Wire Guide Spring (MG10009A) slides into the slot in the Wire Guide Spring Bracket (MG10001A) on the top of the Head located at the front of the machine.

The Foot Switch (PG10230) plugs into the Foot Switch Receptacle (PG10226) which is located in the rear of the machine.

The Rear Work Table (MG10091A) mounts to the rear of the Clincher Arm (MG10052A) using a Rear Table Pivot Pin (PG10247) and a Table Pivot Pin Clip (PG10248). Pay attention to the direction of the Pivot Pin Clip to avoid hitting the Trip Switch Assembly (MG10106A). Assemble the Front Table (MG10083A) to the Clincher Plate Mounting Block (MG10063) after pulling the Adjustment Handle (MG10097) to the left and out of the way. The Adjustment Nut (MG10098) should spring into one of the two holes in the bottom of the right pivot plate on the Front Table. The hole chosen determines whether the StitchMaster will be set up for Flat or Saddle Stitching. Slide a Clevis Pin (PG10247) into the hole in the top of the Front Table, through the Clincher Plate Mounting Block (MG10063) and out the other side. Secure the Clevis Pin with a Table Pivot Pin Clip (PG10248) to keep it in position.

The Trip Switch Assembly (MG10106A) mounts in the slots on the Rear Work Table (MG10091A) after removing the Lock Nut (MG10105) and the Lock Nut Washer (P2126). Refer to **Figure 3** for the Trip Switch mounting. If positioned correctly, the Trip Switch Assembly should use the mounting or right slot on the back of the table and the fingers of the Trip Lever (MG10100) should be visible through the two center slots. Once the Trip Switch Assembly is in place, replace the washer and the lock nut. After the assembly is completed, the entire assembly should slide freely front to back when the lock nut is loosened and remain in place when it is tightened.

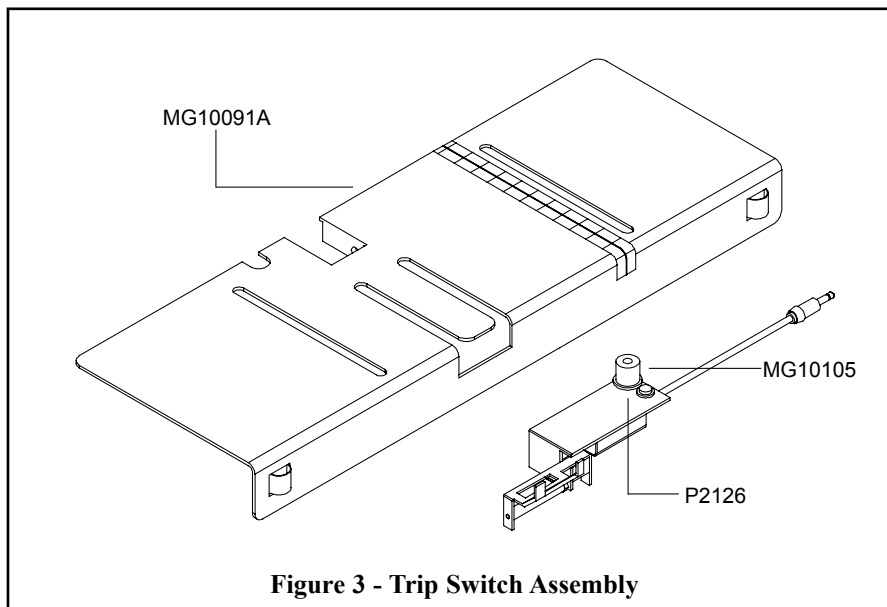

Plug the Trip Switch Plug Assembly (MG10049A) into the Table Trip Jack (PG10227) on the **underside** of the machine on the left.

Once the assembly is complete, turn the machine over by hand a few times using the Shaft Extension Handle (PG10211) located at the rear of the unit. All parts must operate freely before turning on the power. Push and turn the

handle counter-clockwise (looking from the rear of the machine) to manually rotate the machine. You are ready to plug in your StitchMaster, but do not turn on the main power yet.

Operation

Wire Threading (Figure 4)

Before the machine is turned on, disengage the Swivel Operating Spring (9046A) and remove the Swivel Assembly (9038M or 9038A). Thread the wire from the Spool through the Wire Guide Spring (MG10009A), between the Wire Straightener Rollers (9103) and the Wire Straightener Bushing (9065) on the Wire Guide Spring Bracket (MG10001A) as well as between the Wire Straightener Bushing and the Wire Straightener Rollers on the Face Plate (2132BA). Continue to pull the wire through the Tension Pawl (9098) and through the hole in the Face Plate, in the top of the Wire Cutter (9048) Holder and through the Swivel Holder (9043B). At this point, do not worry if the wire is not fed between the Grip (9015) and the Grip Holder area.

Note: The Tension Pawl will hold the wire in the groove in the Wire Straightener Roller (9103). This will allow the wire to feed through the Head but not allow it to “back-up.”

Pull enough wire through the bottom of the Head to clear away what was bent in the threading process. With the Swivel still removed, power the StitchMaster on and switch the Trip Mode Switch (PG10232), found on the back of the Machine, to single mode stitching. Trip either the Foot or the Hand switch to allow the wire to automatically thread between the Grip and the Grip Holder. This will also cut off any excess wire below the Cutters.

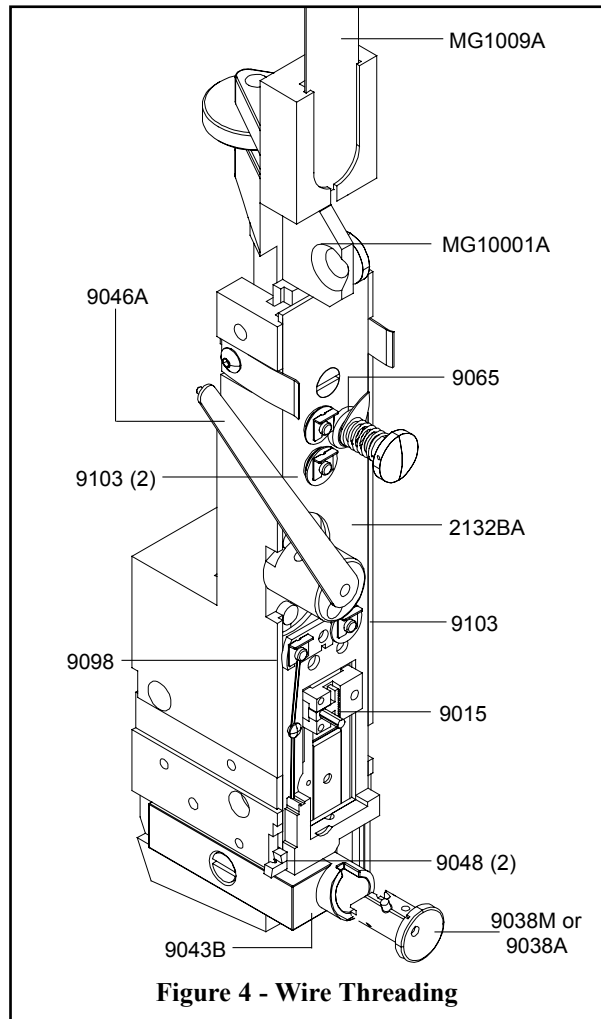

Wire Straightening (Figure 5)

Wire straightness is important so that the stitches are loaded, driven and clinched properly. Although straightness is set at the factory, every roll of wire has varying degrees of twist which makes it necessary for the user to properly straighten the wire prior to production. Easy steps for straightening the wire are listed below.

Make sure the Swivel has been removed before tripping the StitchMaster to avoid jams and the chipping of parts.

! WARNING

Switch the Trip Mode Switch (PG10232), found on the back of the Machine, to continuous stitching and activate the Foot Switch (PG10230). Watch the feeding of the Wire through the Swivel Holder (9043B) and notice the direction the Wire is moving. To compensate for some of the Wire Spool's (25G5 or 21256G5) natural curve, the wire optimally should be feeding slightly to the right. Use the Wire Straightener Eccentric Nut (9067) on the Face Plate (2132BA) to adjust the wire.

Right-to-Left Adjustment

Look through the Swivel Holder (9043B) at the Wire being fed through the Head. If the Wire is feeding to the left or perfectly straight up and down, adjust the Wire Straightener Nut (9067) so that the Wire Straightener Pointer (9070) turns counter-clockwise. Remember, the StitchMaster works optimally if the Wire curves slightly to the right. Allow enough Wire to be fed through the Head so that an accurate assessment can be made. After an adjustment is made it takes approximately four to six stitches to take effect. If the Wire is feeding too far to the right, adjust the Wire Straightener Nut so that the Wire Straightener Pointer turns clockwise.

Front-to-Back Adjustment

Look at the Wire feeding through the Head from the side and make sure that it is straight front-to-back. The Wire Straightener Eccentric (9067) on the Wire Guide Spring Bracket (MG10001A) adjusts the curve if it is not straight. Setting the Wire Straightener Pointer (9070) at a position comparable to 7:00 on the face of a clock is a good place to start. If the Wire is feeding too far to the front, adjust the Wire Straightener Eccentric so that the Wire Straightener Pointer turns clockwise. Allow enough Wire to be fed through the Head, about four to six stitches, to make an accurate assessment. If the Wire is feeding too far to the back, adjust the Wire Straightener Eccentric so that the Wire Straightener Pointer turns counter-clockwise.

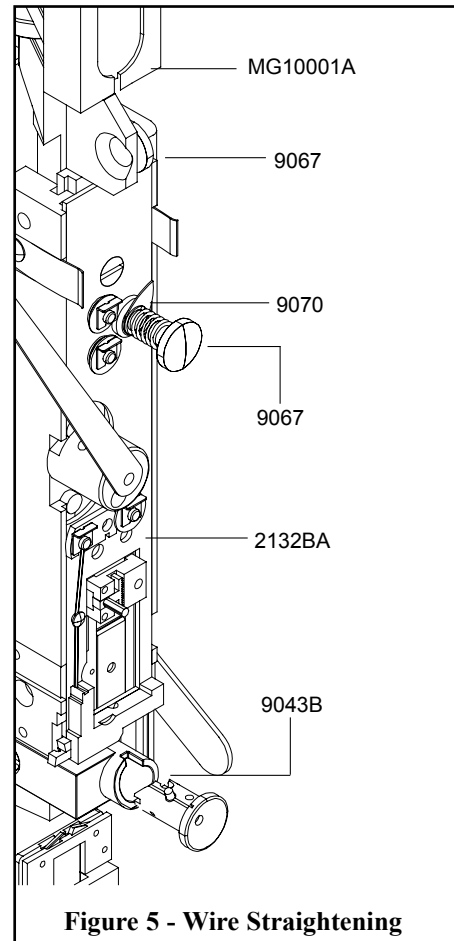

Figure 5 - Wire Straightening

Adjusting the Length of the Left Leg (Figure 6)

Once the StitchMaster has been threaded and the wire straightness has been obtained, it is time to begin stitching. Replace the Swivel Assembly (9038M or 9038A) and secure it with the Swivel Operating Spring (9046A). Set the Trip Mode Switch (PG10232), found on the back of the Machine, to single stitching.

Note: The continuous Trip Mode is used primarily for oiling and wire straightness adjustment.

Activate the Trip (MG10106A) or Foot Switch (PG10230) once to load a piece of wire into the Swivel. Even though the StitchMaster has been tested at the factory, the wire draw adjusted and the legs equalized, the following are directions to make these adjustments if necessary. One control, the Face Plate Adjustment Knob (MG10013) controls both the length of the left leg and wire draw.

Adjusting the Stitch's Left Leg

If after a few stitches, the length of the stitch's left leg is too short compared to that of the right, you will need to adjust the Face Plate (2132BA). Loosen the Wire Guide Spring Bracket Screw (9075) found on the side of the Head. Turn the Face Plate Adjustment Knob clockwise and tighten the screw. If the length of the left leg is too long, loosen the Wire Guide Spring Bracket Screw and turn the Face Plate Adjustment Knob counter-clockwise. After the length of the stitch's left leg is satisfactory make sure to tighten the screw again.

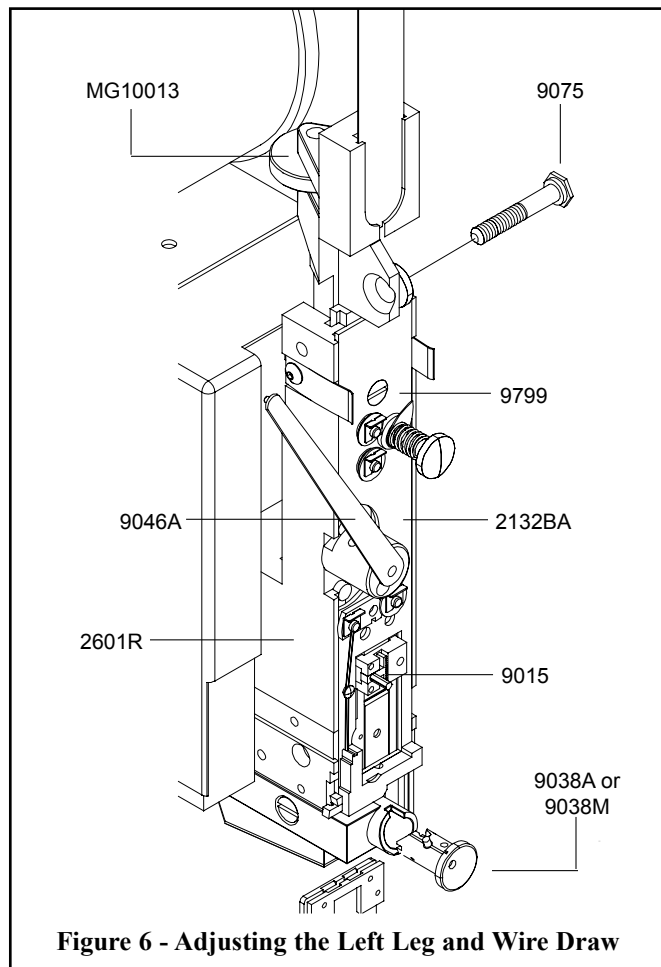

Figure 6 - Adjusting the Left Leg and Wire Draw

Do not operate the StitchMaster Sticher until all guards are in place

CAUTION

Adjusting the Wire Draw (Figure 6)

The overall length of the stitch is controlled by the amount of wire that is drawn from the spool after each stroke of the StitchMaster. To change the overall length of the stitch, loosen the Face Plate Adjusting Lock Screw (9799) on the front of the Head. Turn the Face Plate Adjustment Knob clockwise to raise the Face Plate which draws more wire - making the overall length of the stitch longer. If the overall length is too long, turn the Face Plate Adjustment Knob counter-clockwise to lower the Face Plate and decrease the draw of wire pulled from the Wire Spool. Once the correct length of wire has been achieved, tighten the Face Plate Adjusting Lock Screw. As a rough gauge, the distance the Face Plate is above the Bonnet (2601R) should be equal to the work thickness.

Note: If the Face Plate is adjusted too high (turning the Face Plate Adjustment Knob too far clockwise) the Grip (9015) will lock in an open position and draw no more wire. The StitchMaster has a capacity of 1/4" and will allow no more than that amount of wire to be drawn from the spool.

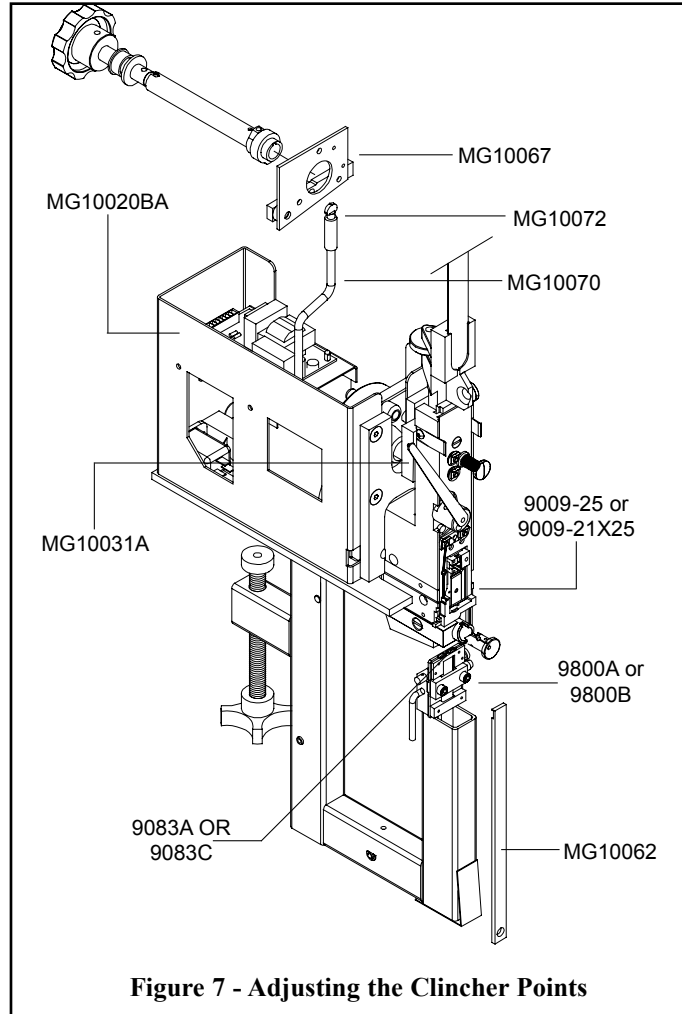

Figure 7 - Adjusting the Clincher Points

Always disconnect the power cord before making any adjustments or servicing the StitchMaster

WARNING

Adjusting the Clincher Points (Figure 7)

Note: The standard StitchMaster accepts only 25 gauge and smaller round wire. If other wire sizes are required contact your local DeLuxe Stitcher Graphic Arts Representative for information.

If the clinch on the staple is not tight enough, the Clincher Points (9083A or 9083C) have to be raised. The Clincher Rod (MG10070) controls the height of the Clincher Points. First remove the Cover (MG10044B) from the Frame (MG10020BA). Release the Clincher Rod from the Cam Lever (MG10067) by pressing down on the bend of the Clincher Rod. Turn the Clincher Rod Stud (MG10072) clockwise to lower the Clincher Slide (MG10062), which lowers the Clincher Points. Engage the Clincher Rod with the Cam Lever again to test the clinch. If the Clincher Points are too low, adjust the Clincher Rod Stud counter-clockwise to raise the Clincher slide, which in turn raises the Clincher Points. Be sure to always re-insert the Clincher Rod and Clincher Rod Stud into the Cam Lever before testing the height of the Clincher Points.

The final position of the Clincher Points should be flush (or slightly above flush) with the Clincher Plate (9800A). The best way to see the position of the Clincher Points is to manually turn the StitchMaster over. When the Driver (9009-25 or 9009-21x25) is at the lowest position of its stroke, the Clincher Points are at their highest position. Turn the Crank (MG10031A) just past this point to reveal the Clincher Points' position. To be sure that the Points are at the best position possible, test the StitchMaster after turning the Clincher Rod Stud 1/2 turn each way. Replace the Cover.

Note: This adjustment is very sensitive - one half turn should affect the clinching considerably.

**Do not operate the StitchMaster Stitcher
until all guards are in place**

 **CAUTION**

Stitching Process

The StitchMaster has been designed to accommodate a variety of jobs. For this reason, adjustable work tables and work stops have been installed on the StitchMaster. The following is a brief explanation of the options available on the machine.

Saddle Stitching (Figure 8)

Push the Springs back into the holes in the underside of the Front Table (MG10083A) with your thumbs, allowing the Rear Work Table (MG10091A) to drop out of the way. Be sure that the Trip Switch Assembly (MG10106A) is adjusted just inside the Rear Work Table so that it does not hit the Front Work Table or the Clincher Arm (MG10052A) as the Rear Work Table is lowered. After the Rear Work Table is out of the way, pull the Table Adjustment Handle (MG10097) to the left and drop the Front Work Table into the saddle position.

Flat Stitching (Figure 8)

Pull the Table Adjustment Handle to the left and lift the Front Work Table to the flat position. Pull the Rear Work Table up until the spring pops into the holes in the back of the Front Work Table.

Note: You may have to push the springs, slightly to clear the Front Table. (see Figure 8)

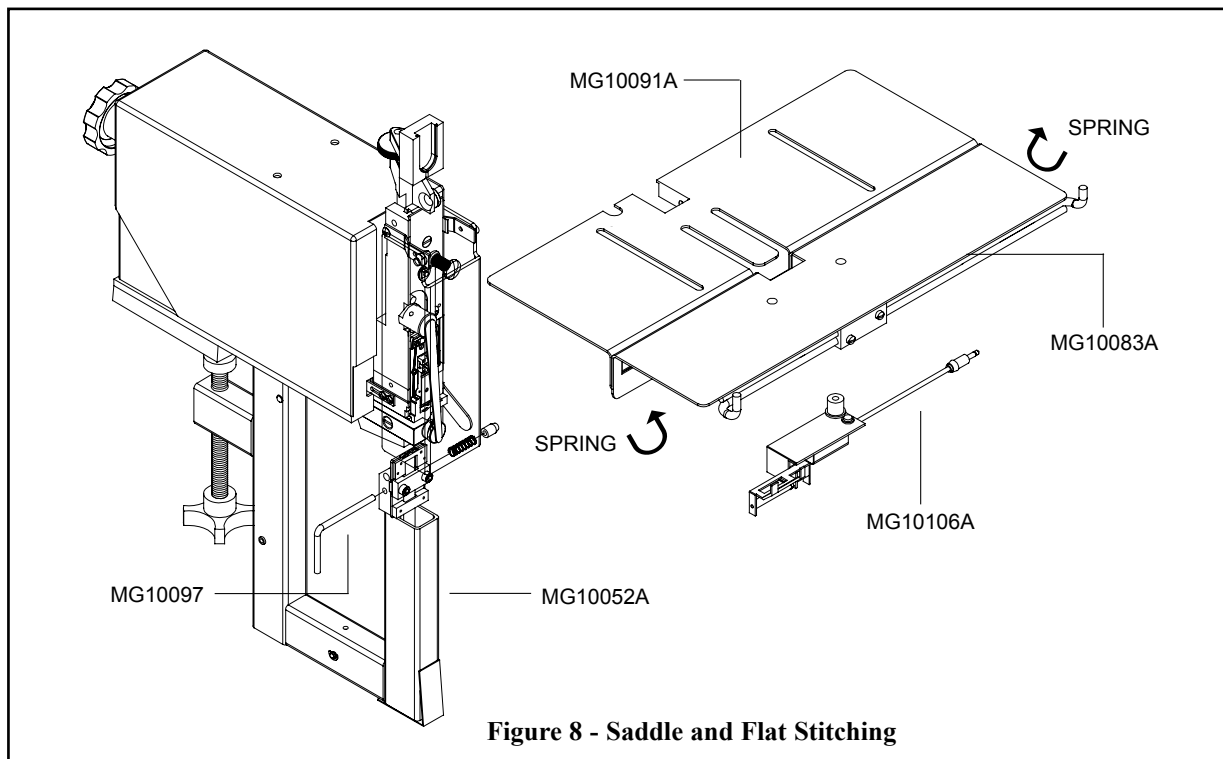

Side Stops (Figure 9)

Loosen the Stop Rod Screws (PG10243) on the front of the Front Work Table (MG10083A) and slide the Left and Right Side Stops (MG10081 and MG10082) out to the necessary distance from the Stitcher Head to position the work under the StitchMaster where you will stitch.

Corner Stitch Stops (Figure 9)

Corner Stitch Stops are applicable to flat work only. Push the Corner Stitch Pins (PG10242) up from the bottom of the Front Work Table (MG10083A) until they lock into place. One or both of the Corner Stops may be used to locate the accurate stitch position.

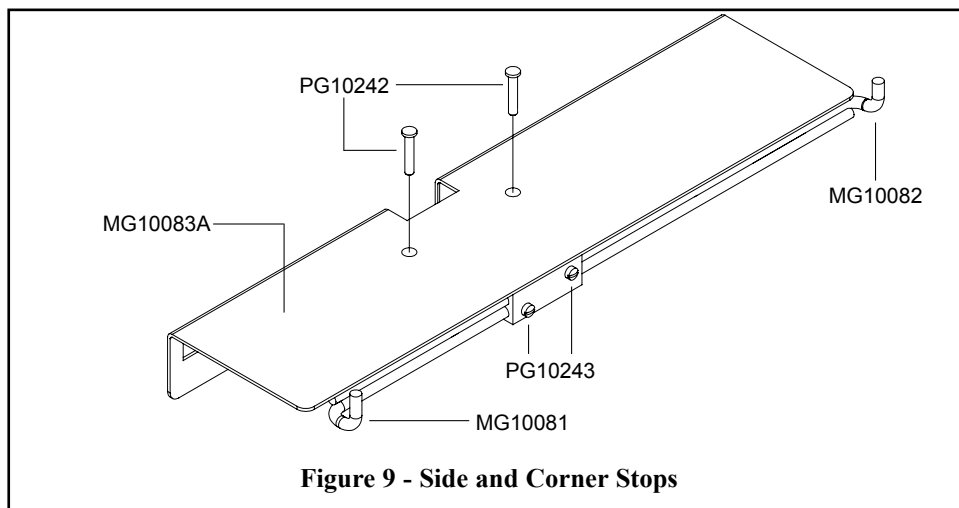

Solid Backstop

The Solid Backstop is an optional assembly which can be ordered from your DeLuxe Stitcher Graphic Arts Representative - order the SMK2 Backstop Kit. The Backstop is mounted on the Rear Table of your StitchMaster and locates the depth of the stitch.

Trip Switch (Figure 10)

The Trip Switch Assembly only works for flat stitching. Loosen the Lock Nut (MG10105) and slide the Trip Switch Assembly (MG10106A), front or back to the desired position on the Rear Work Table (MG10091A). Use the Backstop Gauge Sticker (PG10214) on the Rear Work Table as a guide. When the correct locating position has been determined, tighten the lock nut.

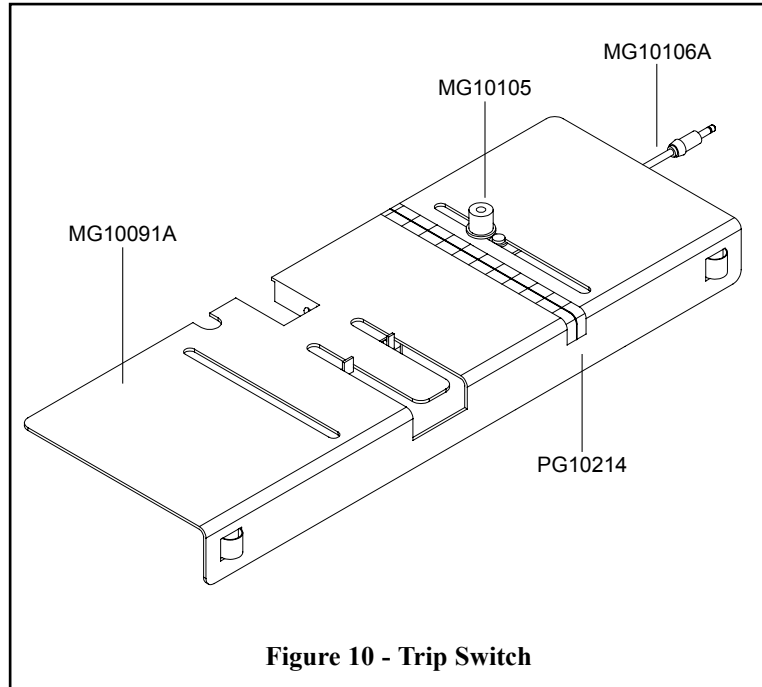

Figure 10 - Trip Switch

Stitch Mode

The Stitch Mode Switch (PG10232) is found on the back of the StitchMaster. (The switch on the left, looking from the rear of the machine.) There are two modes; single or continuous stitching. Single stitching is used for production. In the single trip mode only one stitch will be released at a time, no matter how long the trip switches are activated, whereas the continuous stitch mode the machine will continue to deliver stitches as long as one of the trip switches is activated. The continuous stitch mode is used only for testing and trouble-shooting.

Trip Mode

The Trip Mode Switch (PG10232) is also found on the back of the StitchMaster. (The switch on the right, looking from the rear of the machine.) Either the foot trip or the table trip mode can be selected. The table trip mode or Trip Switch Assembly (MG10106A) can be used only for flat work. The Trip Switch Assembly plugs into the underside of the StitchMaster, on the left. For all saddle stitch work the foot trip mode must be used. Be sure that the Foot Switch (PG10230) is plugged into the rear of the StitchMaster and the Trip Mode Switch is toggled for this mode.

Trouble Shooting (Figure 11)

The following is a brief list of problems and solutions which should cover the majority of situations encountered when stitching with the StitchMaster. Most problems with stitches are due to incorrect adjustments on the machine or to the normal wear of parts.

PROBLEM: The machine does not cycle and the Main Power Switch (PG1022B) is on.

SOLUTION: Make sure the Power Cord (P2581 or PG10410) is properly plugged into a live receptacle. Check to see if the Circuit Breaker (PG10234 or PG10406) has been tripped. If so, push it to reset. If it still does not cycle, make sure the Foot Switch (PG10230) or Trip Switch Assembly (MG10106A) is plugged in and the corresponding Trip Switch position is selected. The Head Guard (PG10003) must be in place to fully depress the safety interlock, otherwise the StitchMaster will not function.

Note: if the Head Guard moves enough to lose contact with the Safety Switch (PG10229) the Head Guard must be rotated upward to clear the Safety Switch and re-closed.

 **CAUTION**

Do not operate the StitchMaster Stitcher until all guards are in place

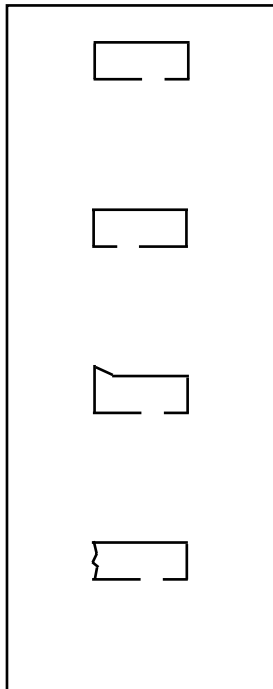

PROBLEM: Right Leg Short

SOLUTION: Shorten the left leg and then lengthen both of the stitch's legs. (See pages 11 - 12)

PROBLEM: Left Leg Short

SOLUTION: Lengthen the left leg. Check the Grip for wear and rotate or replace it if needed. (See pages 11 and 12)

PROBLEM: Corner Buckled

SOLUTION: Check the Driver for a chipped corner and rotate or replace it if needed. (See pages 25 and 26)

PROBLEM: Leg(s) Buckled

SOLUTION: Check the Wire Cutters for wear and rotate or replace if needed. (See pages 23 and 24)

Figure 11 - Troubleshooting



	<p>PROBLEM: Crown Buckled SOLUTION: Check Supporter Spring (9032) tension. If it is too loose adjust it.</p>
	<p>PROBLEM: Stitch in Pieces SOLUTION: Clean and lubricate the Swivel. (See page 21)</p>
	<p>PROBLEM: Corners of the Crown are Rounded SOLUTION: Replace the worn Swivel.</p>
	<p>PROBLEM: Loose Clinch SOLUTION: Raise the Clincher Points. (See pages 13 and 14)</p>
	<p>PROBLEM: Legs are Spread or Contracted SOLUTION: Readjust the Wire Straightener Eccentrics. (See pages 10 and 11) Check the Wire Cutters for wear and rotate or replace if needed. (See pages 23 and 24) Check the Bender Bar for wear in the grooves and replace if needed.</p>

Figure 11 - Troubleshooting

Maintenance

Lubrication (Figure 12)

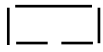
Your StitchMaster has been fully lubricated at the factory, but regular preventative maintenance will result in superior performance and longer life of the machine. A good rule of thumb is to oil the StitchMaster's critical points every five pound wire spool change or every month, whichever comes first. Use one drop of any standard S.A.E #10 oil in the following lubrication points:

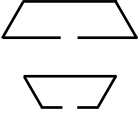
Always disconnect the power cord before any maintenance or adjustments are made to the StitchMaster

CAUTION

- at the top of the Bonnet (2601R) on either side of the Wire Guide Spring Bracket (MG10001A)
- the oil hole in the Swivel Operating Hub (9163)
- the oil holes in the Face Plate (2132BA)
- on the Bender Bar Latch (9014) and on the Grip (9015)
- the oil hole in the Driving Shaft Connection Link (2215)
- the opening in the Swivel Holder (9043B)
- where the Clincher Points (9083A or 9083C) pivot
- the Wire Cutter Operating Slide slot (9049)
- on the Wire Straightener Rolls (9065) and Tension Pawl (9098)

Cleaning (Figure 12)

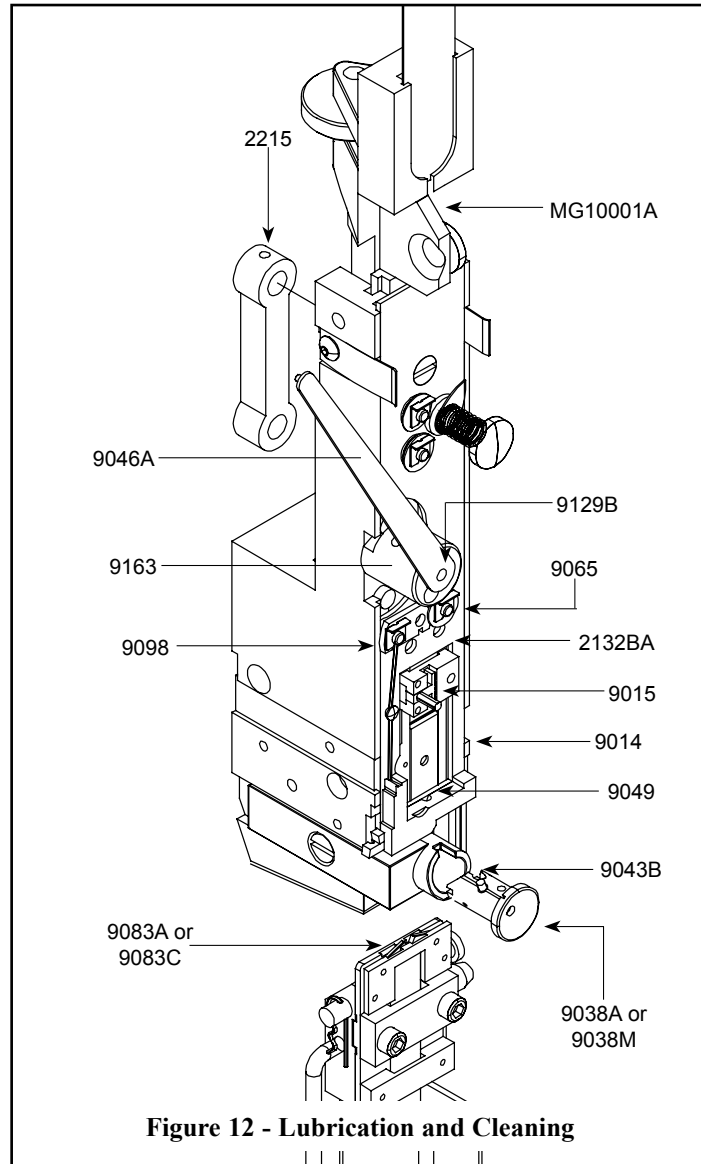

Figure 12 - Lubrication and Cleaning

In addition to proper lubrication, routine cleaning is important for the maintenance of your StitchMaster. The following areas should be cleaned every three months:

- **Swivel Assembly (9038M or 9038A):** remove and wash in an oil-dissolving solvent, dry and relubricate.
- **Swivel Holder (9043B):** clean inside the Swivel hole.
- **Swivel Operating Lever and Stud:** remove the Swivel Operating Spring (9046A) and Lever (9163). Clean the Swivel Operating Spring Stud (9129B) and the holes in the Lever, relubricate and replace.

Note: Use care when replacing the Swivel Operating Lever to avoid serious damage being done to the head.

- **Anywhere that dust, oil or pieces of wire and paper have built up** - for example: the Grip, Clincher Points and around the Wire Straightener Rollers.

Ordering Spare Parts

In time, you will need to replace some parts in your StitchMaster. When this happens, first locate the needed part in one of the following diagrams. Then locate the DeLuxe Stitcher part number and contact your Graphic Arts Representative to order the part by the part number, description and quantity.

Always disconnect the power cord
before any maintenance or adjustments are
made to the StitchMaster

CAUTION

Replacing Spare Parts

The following are some of the more common wear parts which will need to be removed and replaced in your StitchMaster. Most replacements require the Stitcher Head to be removed from the StitchMaster. This explanation and instructions to do so will be given first, then a more specific description for each common wear part will follow.

General Maintenance and Repair (Figure 13)

While some adjustments can be made to the StitchMaster and the stitcher head, most maintenance and general repairs have to be made with the stitcher head removed from the machine.

Cut the wire from the wire spool just below the Wire Guide Spring Bracket (MG10001A).

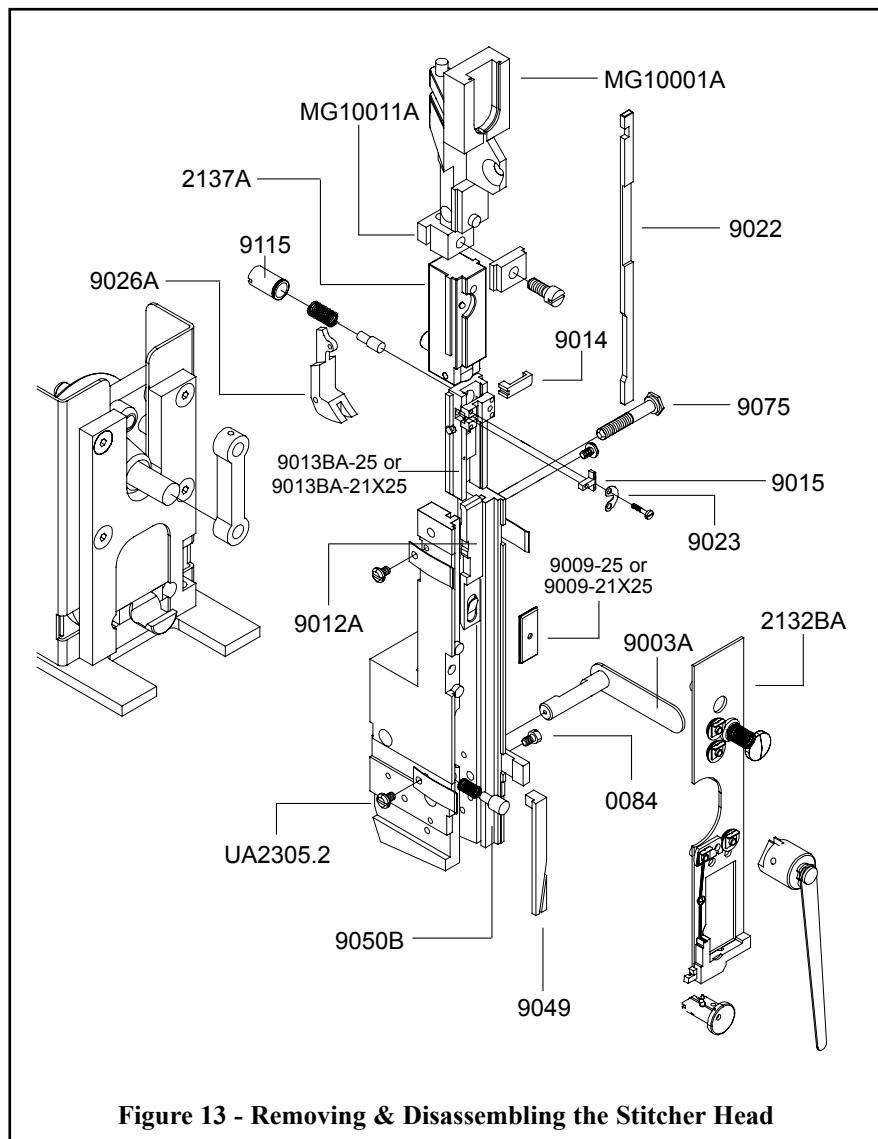

Figure 13 - Removing & Disassembling the Stitcher Head

Pull the remaining wire, from the stitcher head, out from the bottom. Remove the Wire Guide Spring (MG10009A) from the Wire Guide Spring Bracket (MG10001A).

Loosen the Bonnet Clamp Eccentric Handle (9003A) and remove the Stitcher Head from the StitchMaster. Place the Head on a clean work area. Be aware that the Driving Shaft Connection Link (2215) is removed from either the Driving Slide Assembly (2137A) or the Crank (MG10031A).

Always disconnect the power supply before assembling the StitchMaster or making any adjustments.	CAUTION
---	----------------

Removing and Replacing the Wire Cutters (Figure 14)

The Wire Cutters (9048) have two cutting surfaces, each of which may be used by reversing the ends and positioning in the Face Plate (2132BA). To change or reverse the Wire Cutters, remove them from the Face Plate. Loosen the Screws (UA2305.2) in the Face Plate Clips (9056) and the Screw (0084) in the Solid Face Plate Clip (9171). Once the clips are loosened, the Face Plate can be tilted away from the Bonnet (2601R) to remove the Wire Cutters. Slide the existing or new Wire Cutters into the cutter holder in the Face Plate - with the tongue of the upper cutter facing the front and the tongue of the lower cutter facing back. Before tightening the Face Plate Clip Screws (UA2305.2) and the Solid FacePlate Clip Screw (0084), make sure that each Cutter has slipped into position in the Face Plate and in the Wire Cutter Operating Slide. (9049) Press the Face Plate under the Face Plate Clips and tighten the Face Plate Clip Screws. Always rotate the StitchMaster manually before switching the power on to ensure free mechanical movement. This will prevent serious damage to the Head.

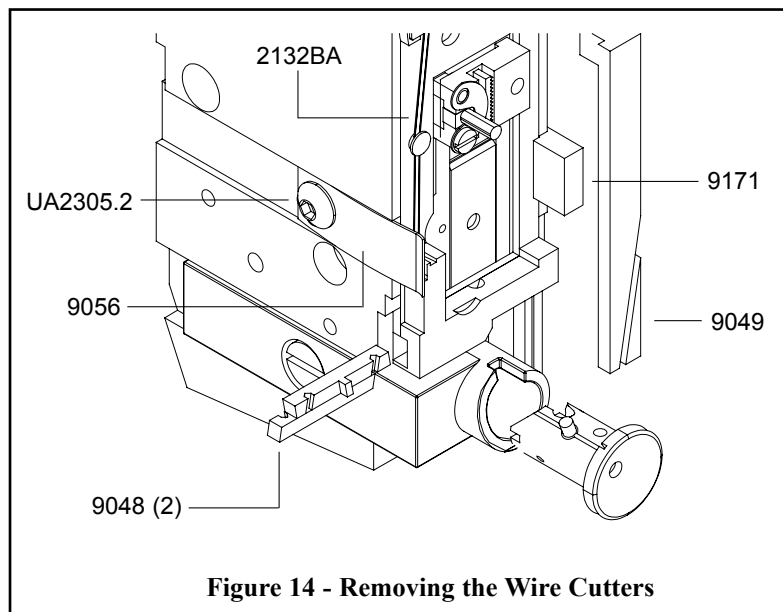

Figure 14 - Removing the Wire Cutters

Removing and Replacing the Grip (Figure 15)

The Grip (9015) can be used in two positions so that when the gripping teeth show signs of wear, it may be reversed to extend the life of the part. Loosen the Grip Retaining Clip Screw (9020) and swing the Grip Retaining Clip (9023) out of the way. Remove the Grip and reverse its position within the Grip Holder. If both edges are worn, replace the part.

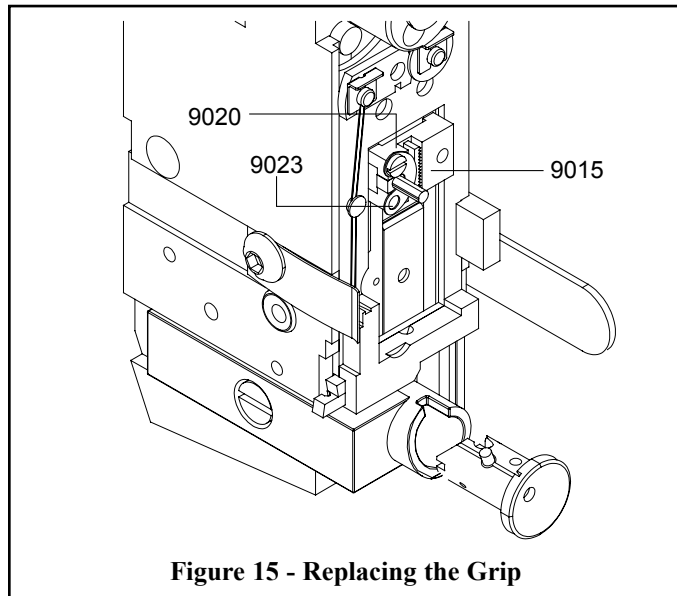

Figure 15 - Replacing the Grip



Always disconnect the power supply before assembling the StitchMaster or making any adjustments.

Removing and Replacing the Tension Pawl (Figure 16)

The Tension Pawl (9098) is double-ended so that when one end is worn, it can be reversed, increasing the life of the part by providing a new gripping surface. To remove the Tension Pawl, disengage the Tension Pawl Spring (9134) from the Tension Pawl and remove the Wire Straightener Roll Clip (9124). Flip the Tension Pawl over so that a new surface is in contact with Wire Straightener Roller (9103) and replace the E-clip. Make sure that the Tension Pawl is under the flange in the Wire Straightener Roll before re-engaging the Tension Pawl Spring. If both ends of the Pawl are worn, replace the part.

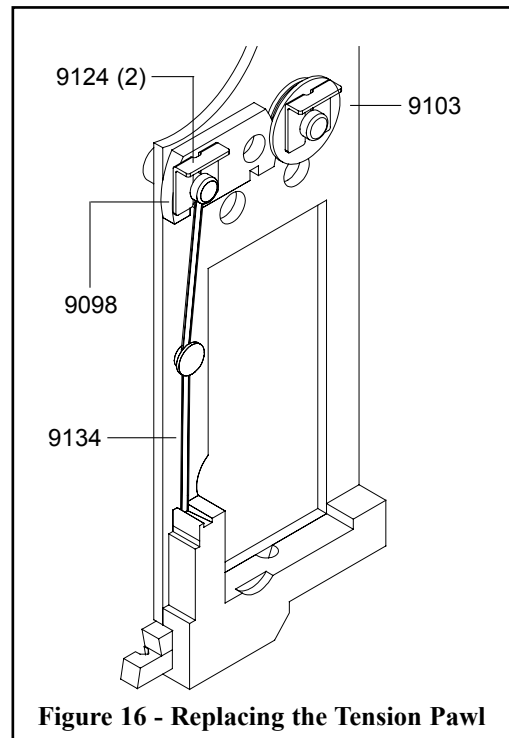

Figure 16 - Replacing the Tension Pawl

Removing and Replacing the Driver (Figure 17)

The Driver (9009-25 or 9009-21x25) is also double-ended so that when it is worn, it can be reversed to provide a new driving surface and increase the life of the part. The Driver can be removed and replaced without having to remove the Head from the StitchMaster. Rotate the Shaft Extension Handle (PG10211) manually until the Driver is at the top of its stroke. Insert the supplied Driver Release Pin (5160) into the hole in the Driver. This will depress the Driver Retaining Spring (9010) so that you will be able to push the Driver down along the Bender Bar (9013BA-25 or 9013BA-21x25) until it can be pulled out from the bottom of the Head. Either reverse the existing Driver or replace it with a new one. Slide the Driver back up through the Bender Bar until you hear the Driver Retaining Spring click, indicating that the Driver is in its correct position.

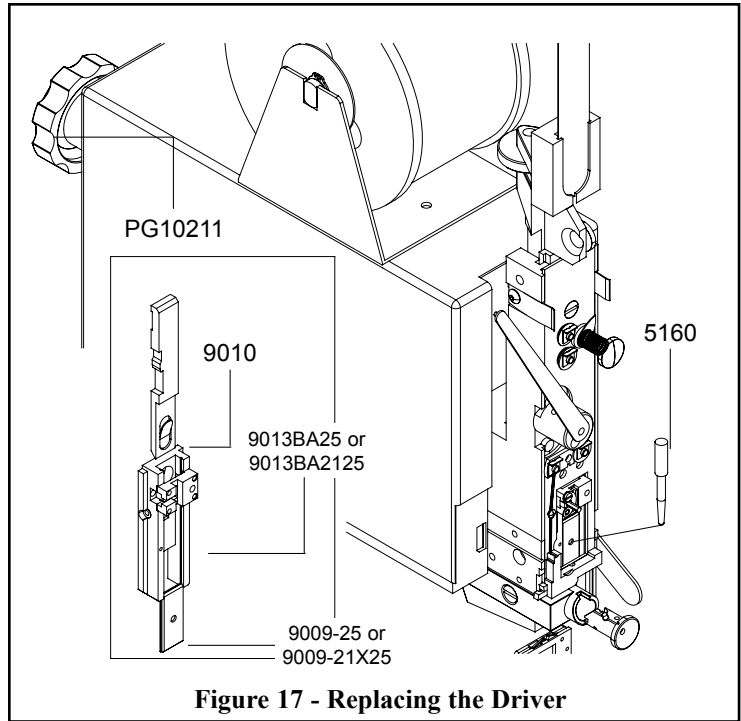

Figure 17 - Replacing the Driver

Changing the Clincher Points (Figure 18)

The Clincher Points (9083A or 9083C) are double-edged and may be reversed when worn or chipped, which doubles their life. Loosen the Screw (UA3804.7) and rotate the Clincher Arm Cover (MG10075) until all internal components are visible. Release the Clincher Slide Retaining Screw (UA3804.7) and remove the Washer (PW10). Pull the Clincher Slide (MG10062) off the Clincher Lever (MG10061) and slip it out of the Clincher Plate (9800A). Swing the Clincher Points upward and pull them out of the Clincher Plate. Either reverse the existing Points or replace them with new Points. Insert the Clincher Slide back into the Clincher Plate and over the Clincher Lever. Replace the Washer and the Screw on the Clincher Slide and replace the Clincher Arm Cover with its Screw.

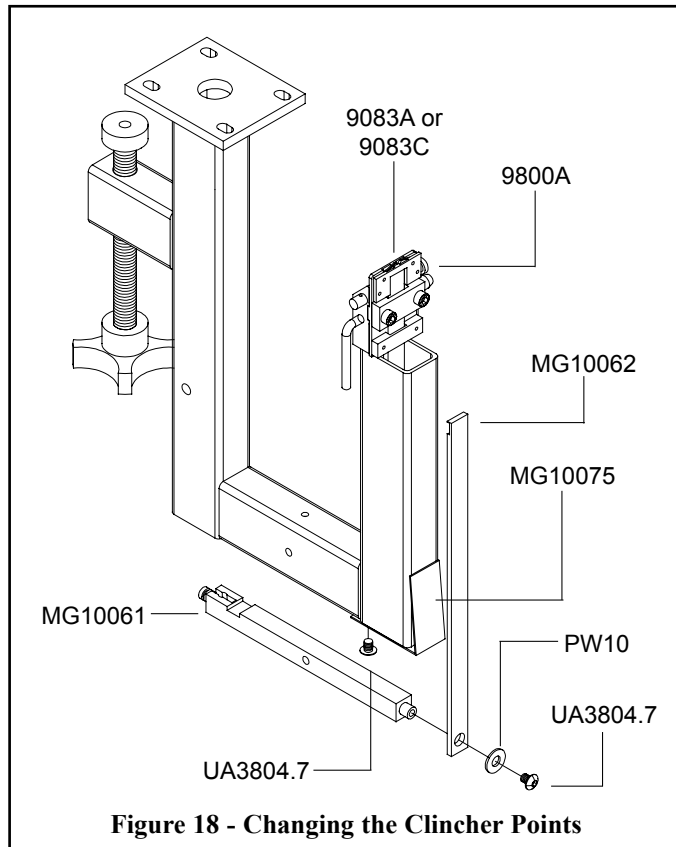

Figure 18 - Changing the Clincher Points

Always disconnect the power supply before assembling the StitchMaster or making any adjustments.

⚠ CAUTION

Replacing the Stitcher Head (Figure 13)

Once the replacement parts have been installed or the existing wear parts have been reversed, the Stitcher Head can be mounted back on the StitchMaster. The following steps will make the process easier: Make sure that the upper end of the Driving Shaft Connection Link (2215) is attached to the Crank (MG10031A) with the oil hole up and the lower end is attached to the Driving Slide Pin (2103B). Position the Bonnet Clamp Eccentric (9003A) at an 11:00 position and slide the Head onto the Bonnet Clamp Block (9002) against the Head Mounting Plate (MG10026). Once the Head is lined up, pull the Bonnet Clamp Eccentric down, to approximately a 9:00 position, or until the Head is firmly fastened.

Modifications

Clincher Arm Alignment (Figure 19)

Always disconnect the power supply before making any adjustments or servicing the StitchMaster

⚠ WARNING

All of the StitchMaster's adjustments, including the alignment, are set at the factory. However, sometimes it becomes necessary to change these adjustments. The Clincher Arm Alignment is probably the easiest of all the adjustments, but the most crucial. Without correct alignment, a good stitch can never be achieved. There are three separate adjustments necessary to align the Clinchers with the Stitcher Head.

Remove the Wire Spool (25G5 or 2125G5) and Cradle (MG10113) from the top of the StitchMaster. Release the StitchMaster from its work table or stand using the Clincher Arm Clamp Knob (P3793) and flip the entire StitchMaster over. Loosen the four Screws (UA4110.1) on the base of the Frame (MG10020A) to release the Clincher Arm (MG10052A). Align the groove in the Bender Bar (9013BA-25 or 9013BA-21x25) or the groove for the Driver (9009-25 or 9009-21x25) with the

center of the Clincher Points (9083A or 9083C) in the Clincher Plate (9800A) by manually turning the StitchMaster over. Adjust the Clincher Arm to the correct position, checking both the side-to-side straightness and the front-to-back straightness. Once the correct position has been achieved, tighten the four screws on the base of the frame. The screws should be tightened slightly in a clockwise motion until the Arm is secure. Turn the StitchMaster back over and secure to the work table or stand.

Once the Clincher Arm is aligned with the Stitcher Head, the Clincher Plate Mounting Block (MG10063) can be better aligned. The two Screws (UA4808.3) securing the Clincher Plate Mounting Block and Clincher Plate can be loosened to allow the Mounting Block and Clincher Plate to be adjusted up or down. Ideally, the Clincher Plate should be touching the Driver when the Driver is at the lowest point of its stroke.

If even more fine tuning is necessary, the two Screws (UA3812.2) in front of the Clincher Strap (MG10060) can be loosened. These screws secure the Clincher Plate to the Clincher Plate Mounting Block. Once loosened, the Clincher Slide (MG10062) and Clincher Plate can be adjusted to the right or to the left to better align the Clincher Points with the Stitcher Head.

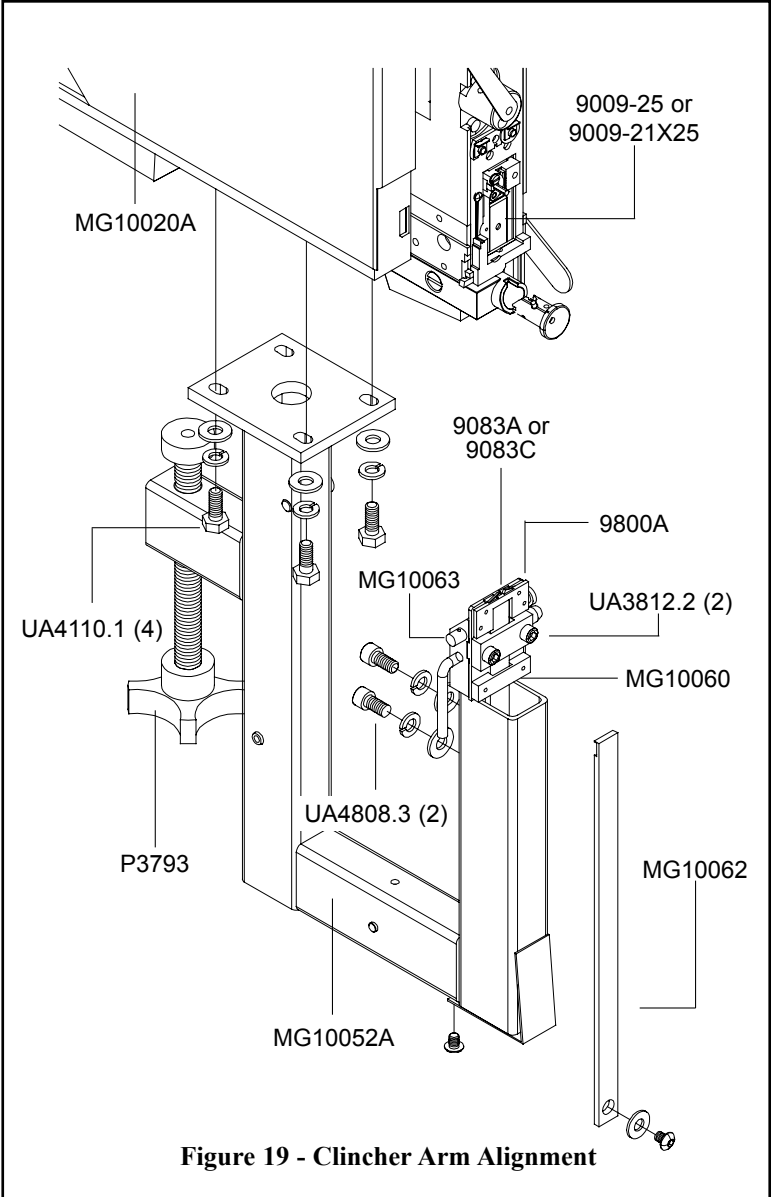

Figure 19 - Clincher Arm Alignment

Timing (Figure 20)

The timing in a StitchMaster determines the knock-off point of the Crank (MG10031A). The timing is set before the StitchMaster leaves the factory, but the following instructions can be used if the timing has to be changed or re-adjusted. The end of the Crank without the Screw (UA3808.1) should stop at a position comparable to 11:00 or 12:00 o'clock on a face of a clock. To adjust this position, loosen the Screw (PG10326) in the Control Cam (MG10032) and rotate it in the direction opposite to the way the Crank needs to move to stop between 11:00 or 12:00 o'clock. Trip the StitchMaster to double-check this position. Remember to tighten the Screw (PG10326) after the adjustments have been made.

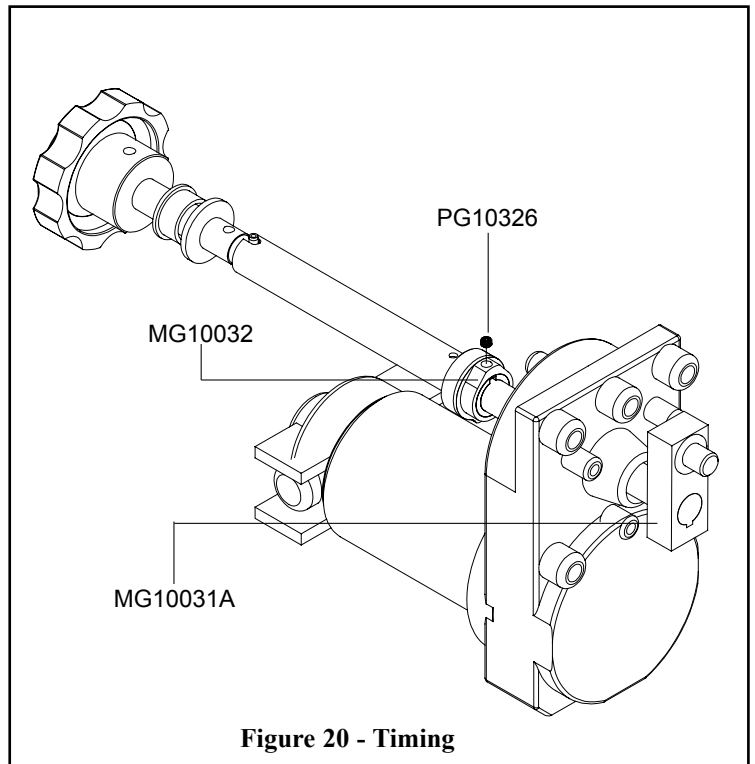
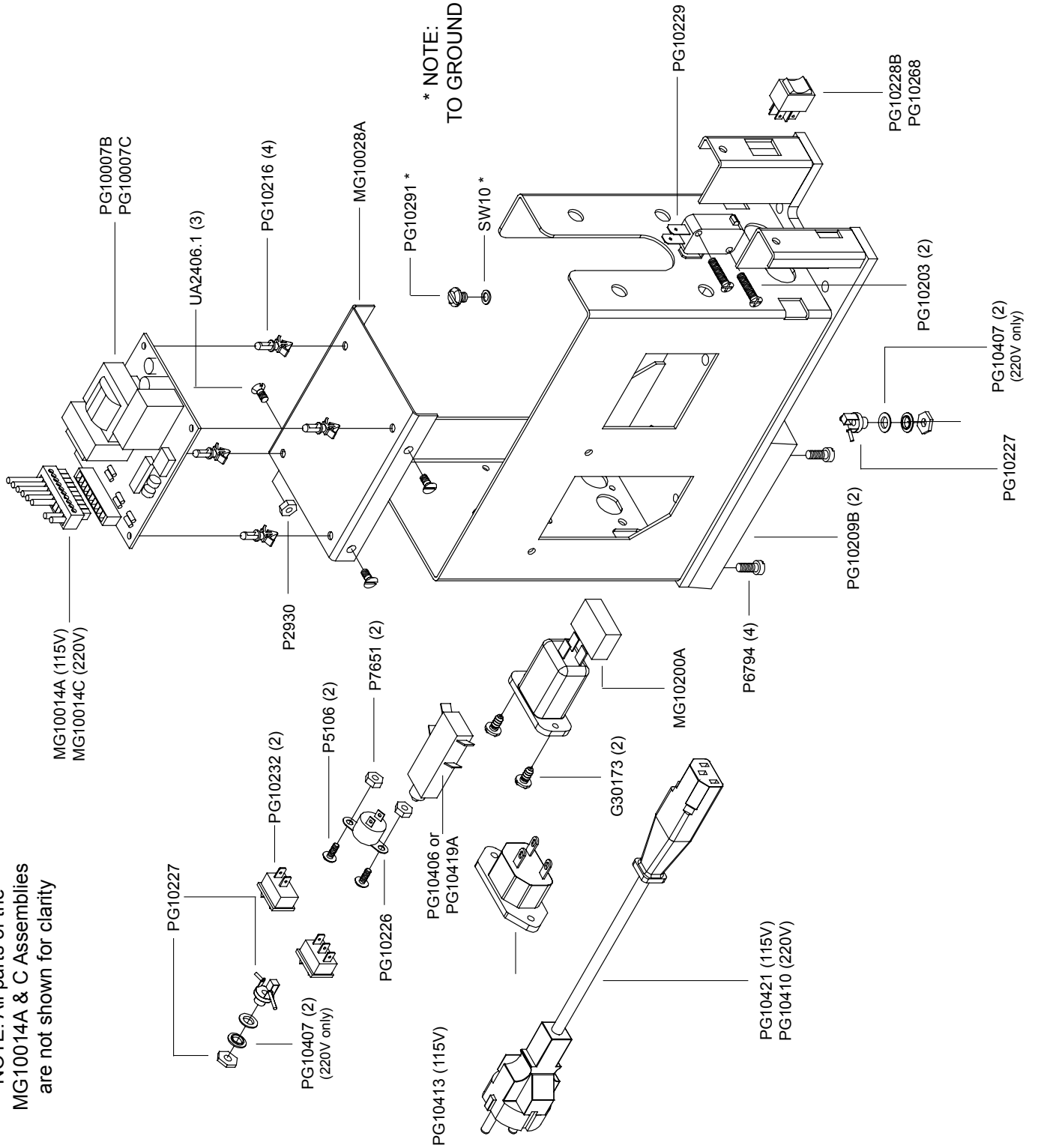

Figure 20 - Timing

Frame Assembly

NOTE: All parts of the MG10014A & C Assemblies are not shown for clarity



Cam Switch Assembly

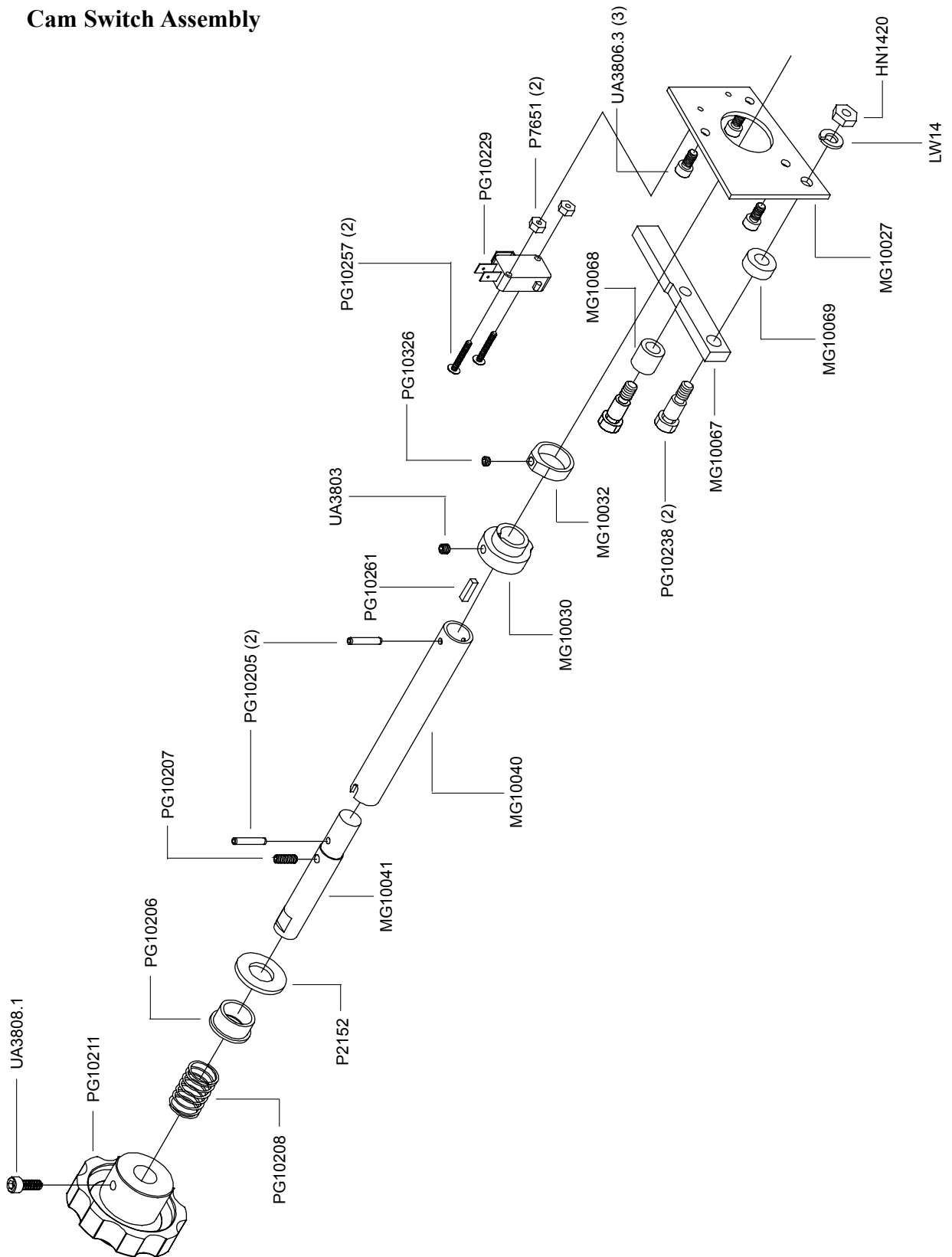

Gear Motor Assembly

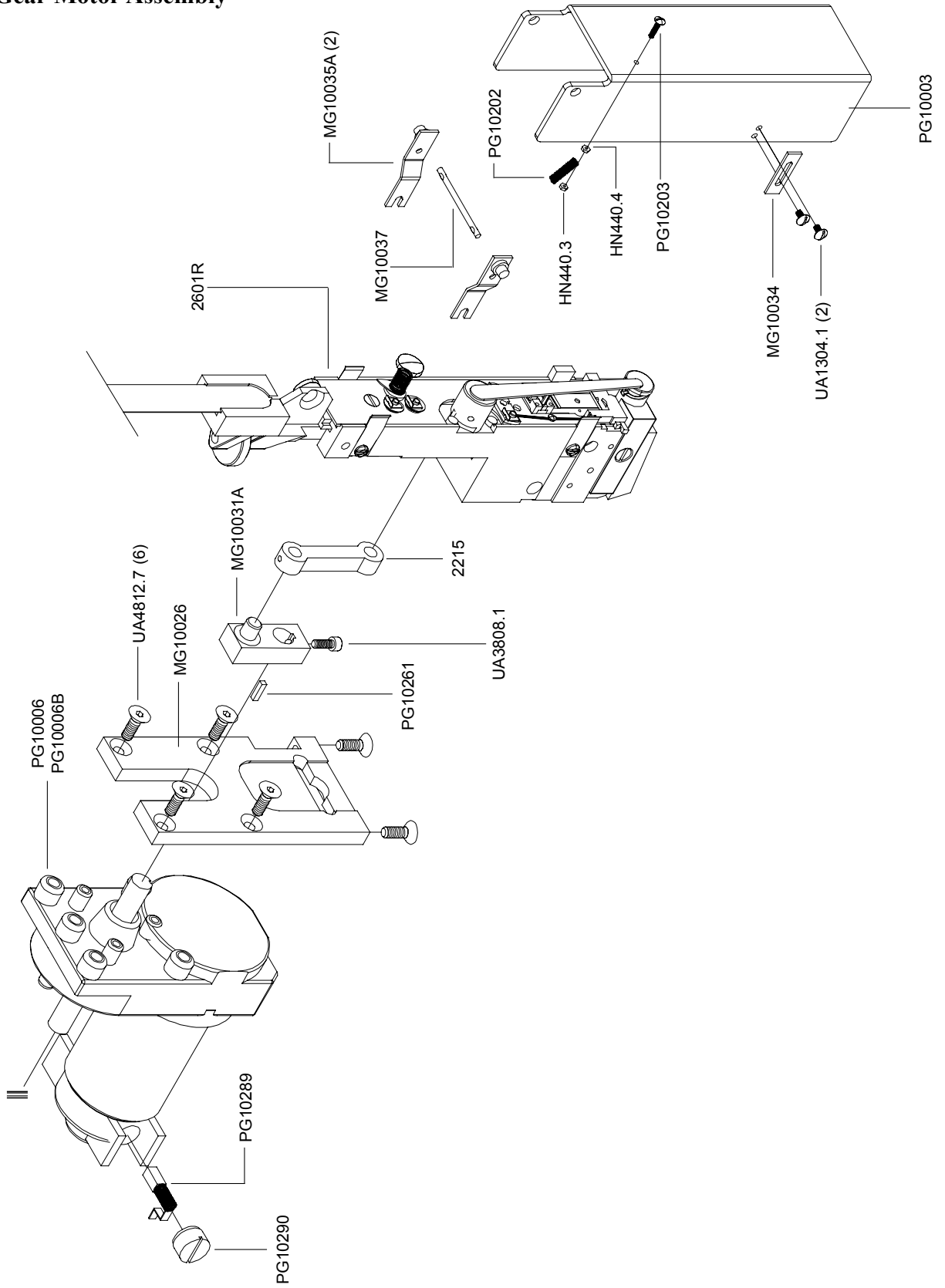

Clincher Arm Assembly - Assembly Part Number MG10051A

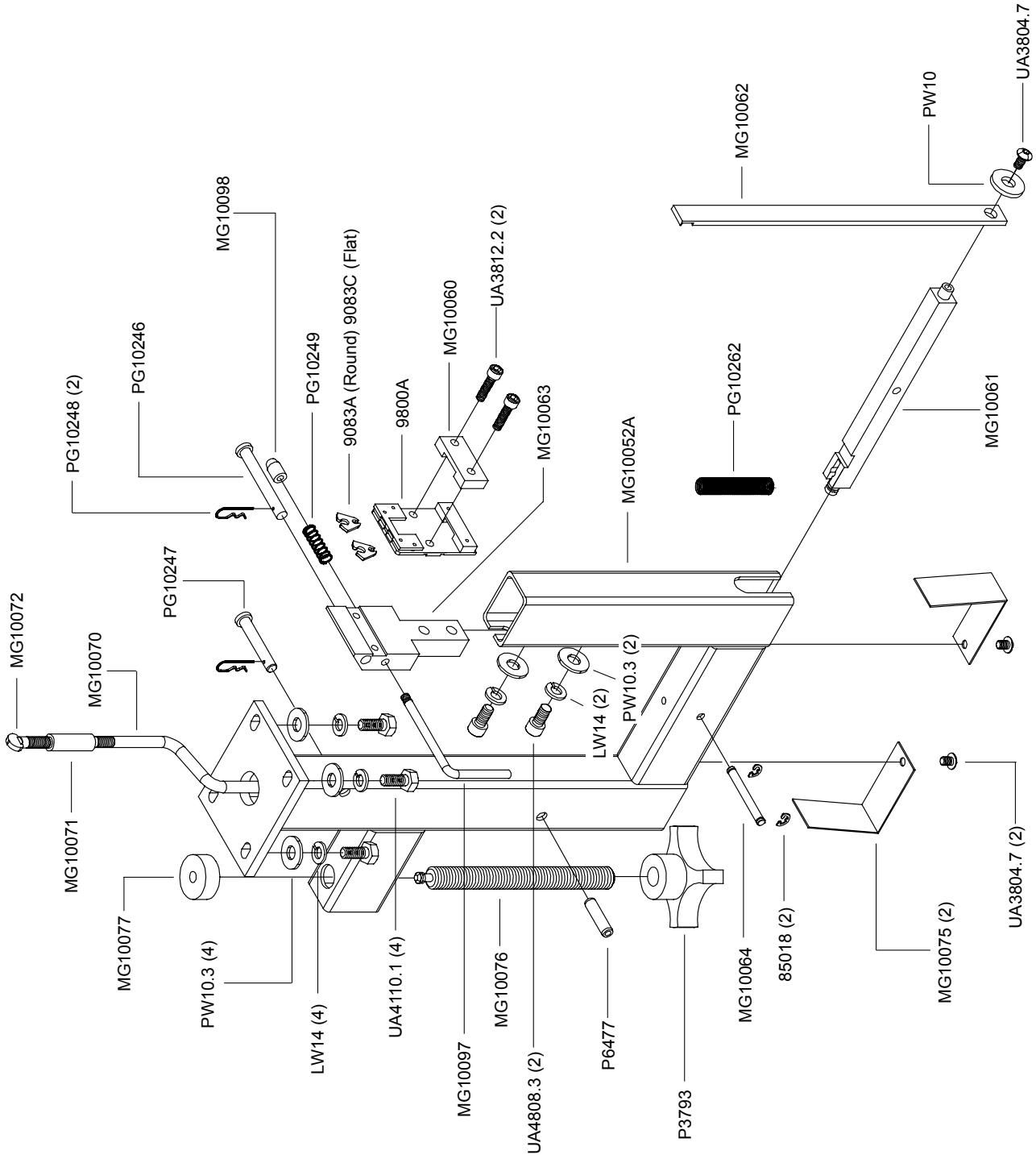

Tables and Trip Assemblies

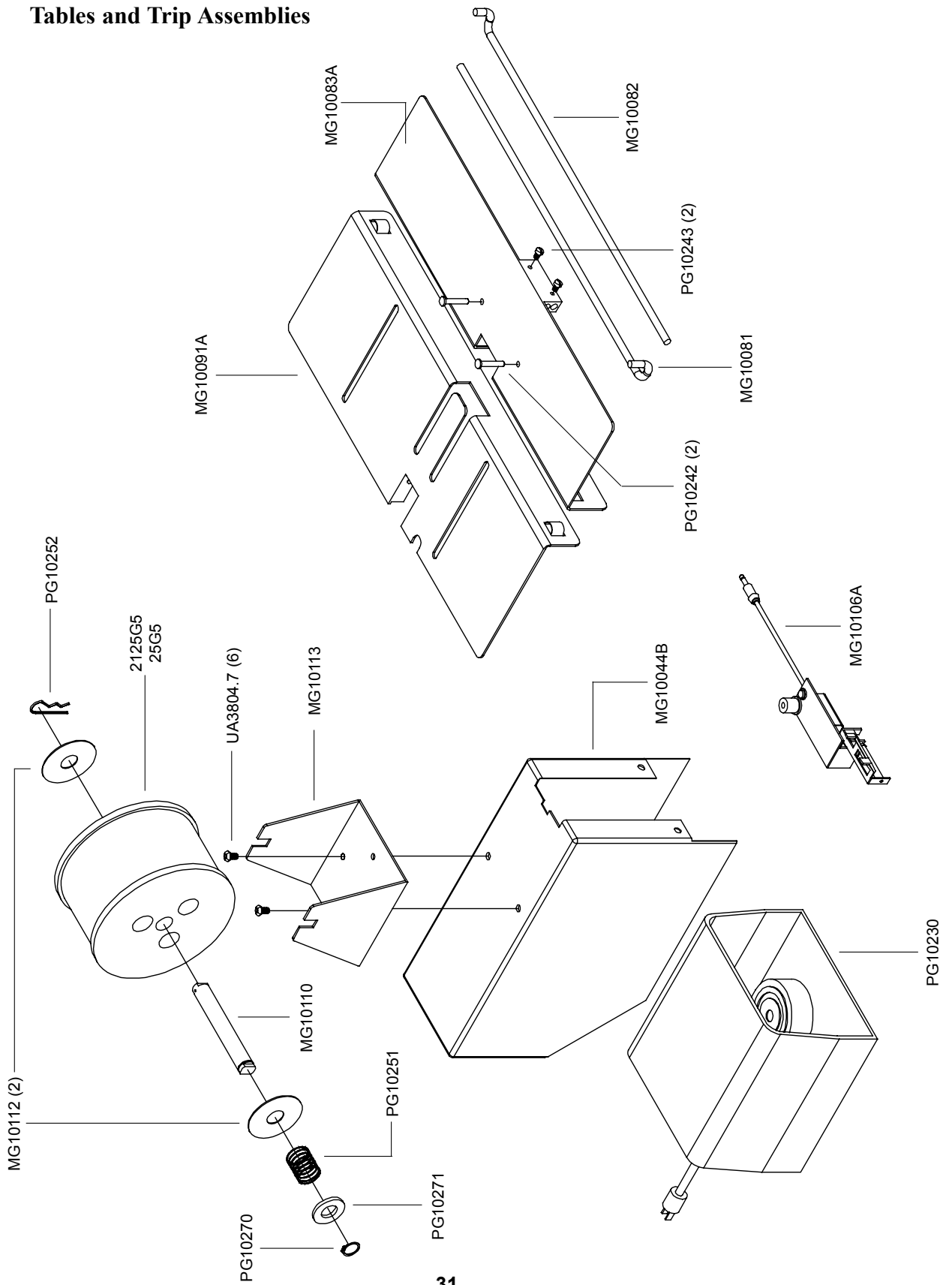

The StitchMaster

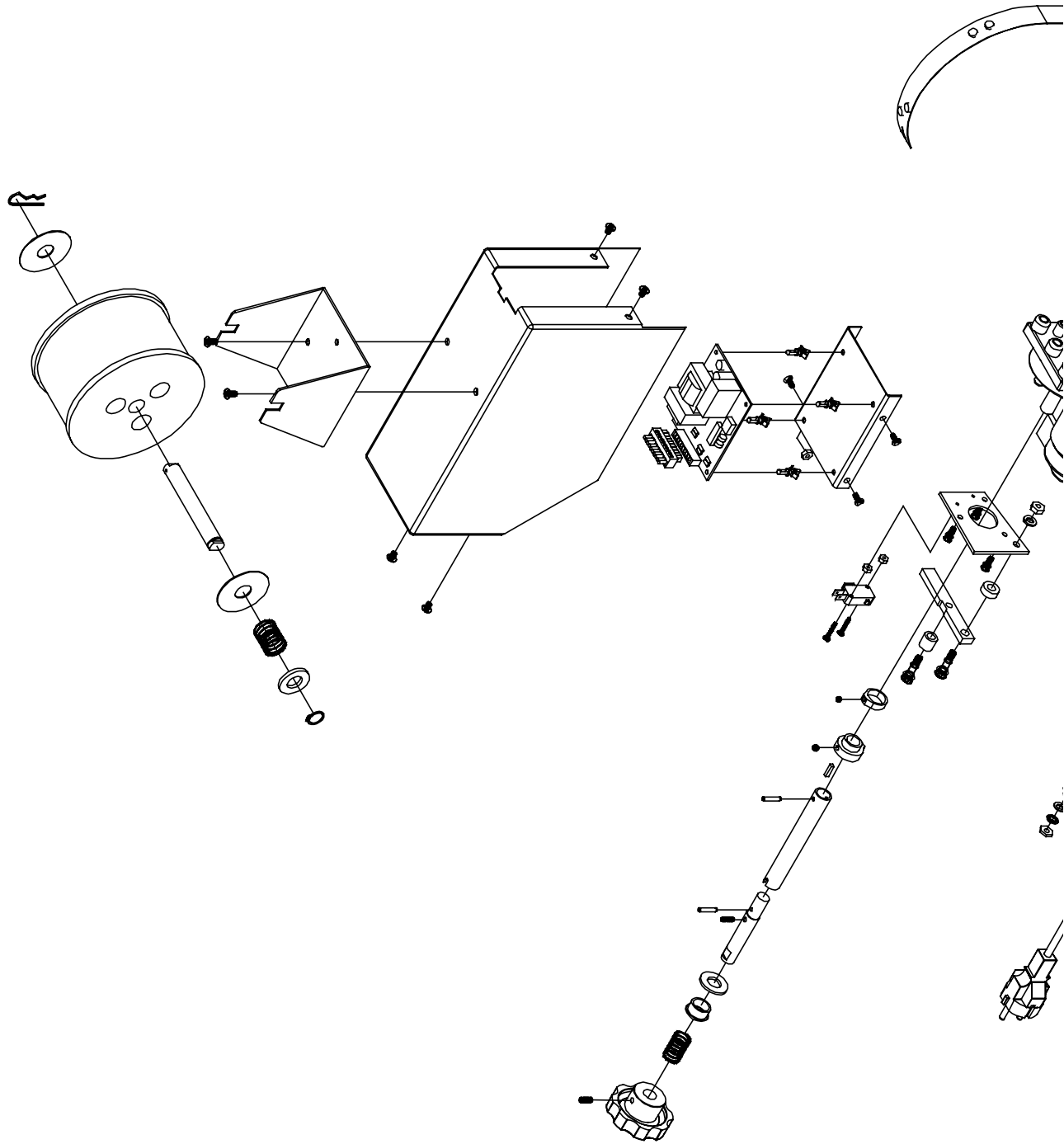

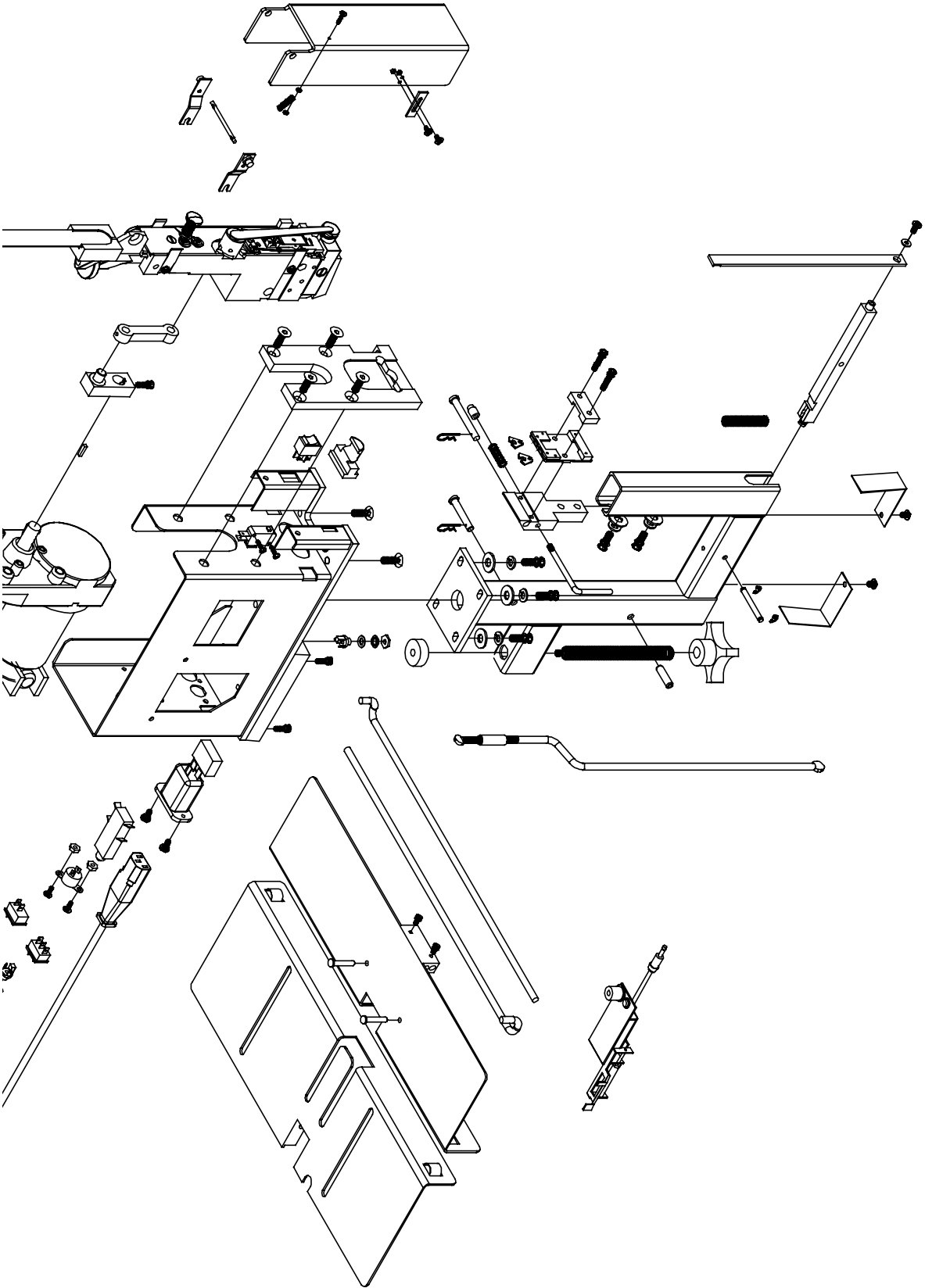

The 26 Stitcher Head - Bonnet Assembly

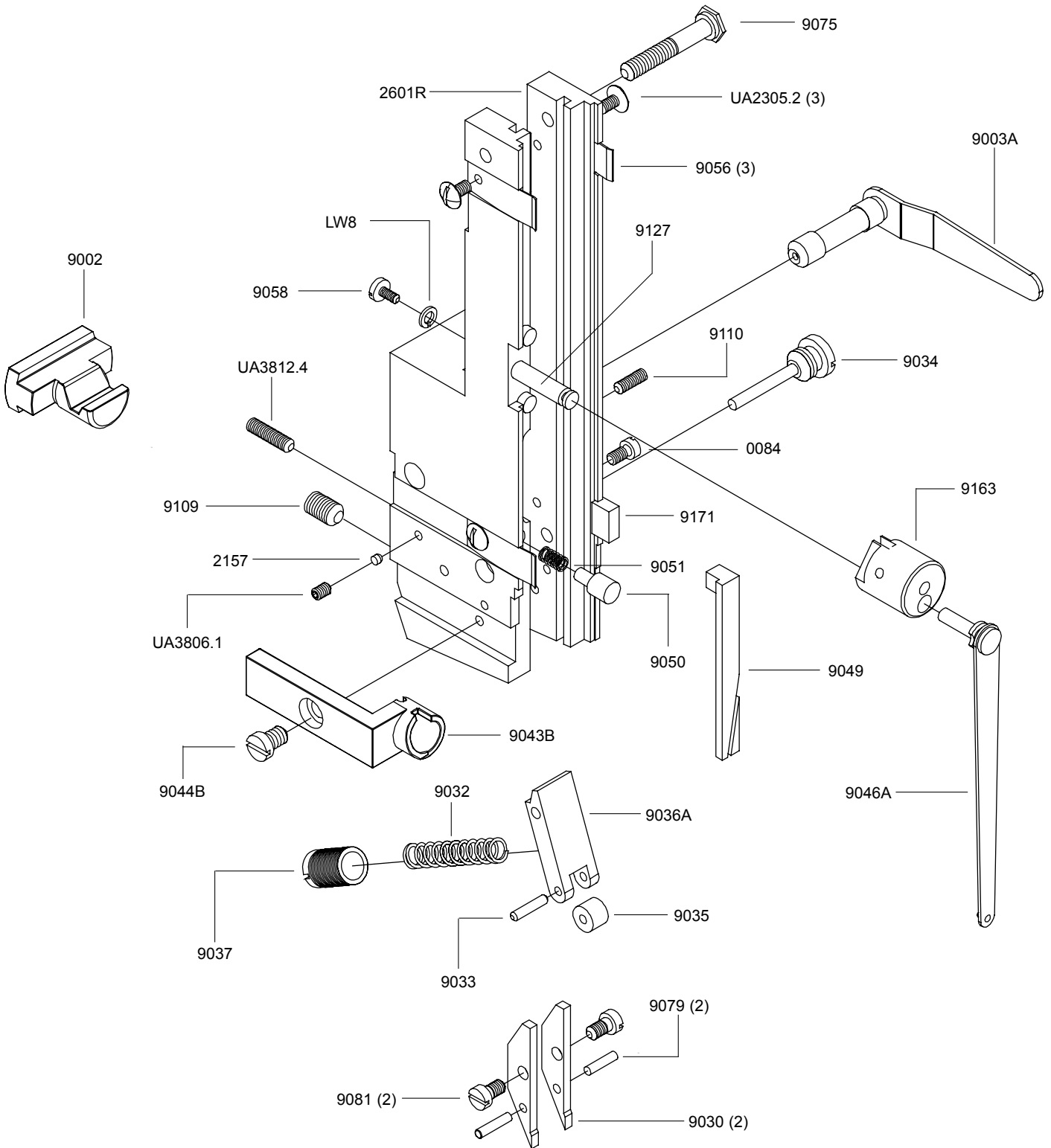

The 26 Stitcher Head - Face Plate Assemblies

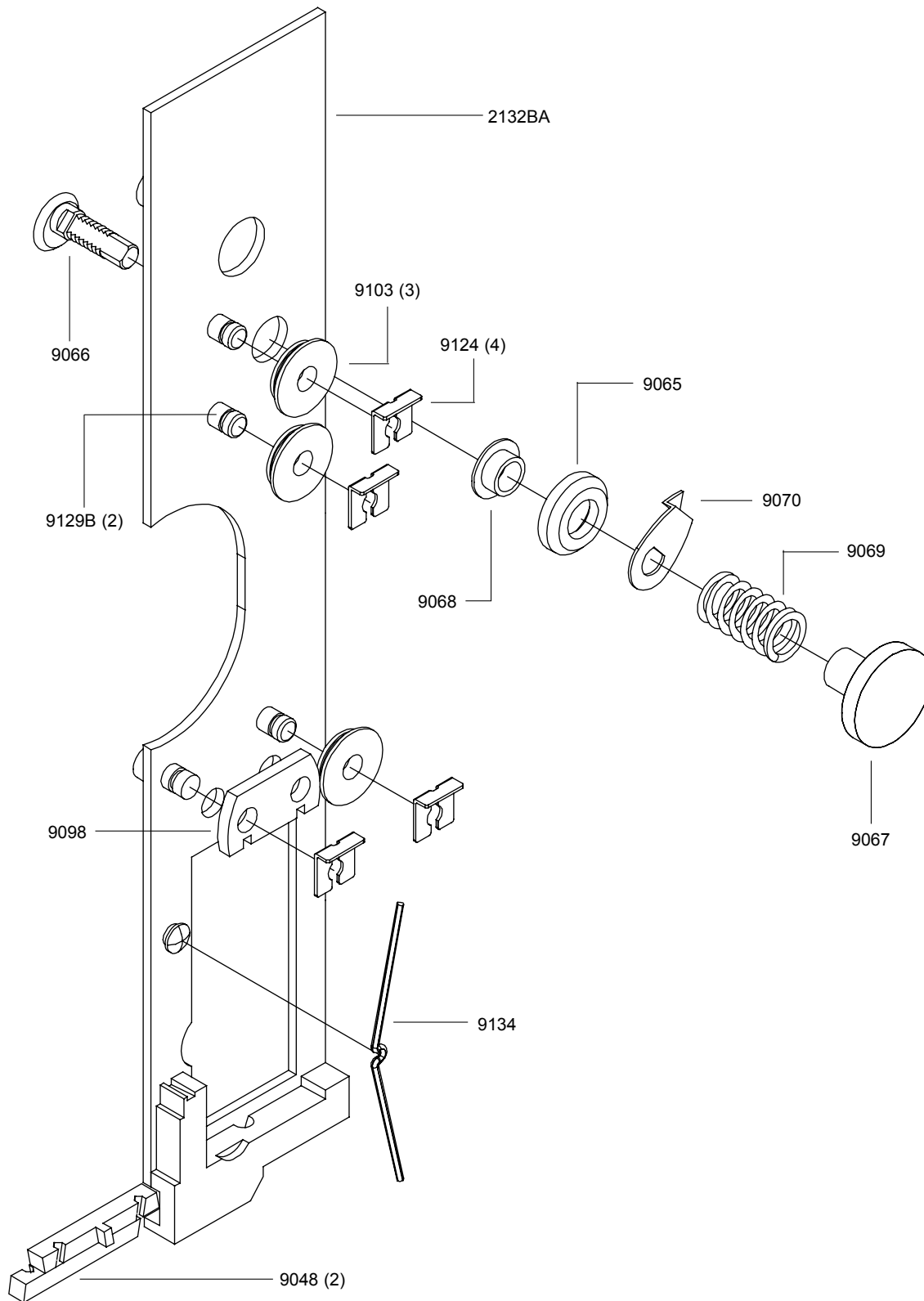

The 26 Stitcher Head - Sub Assemblies

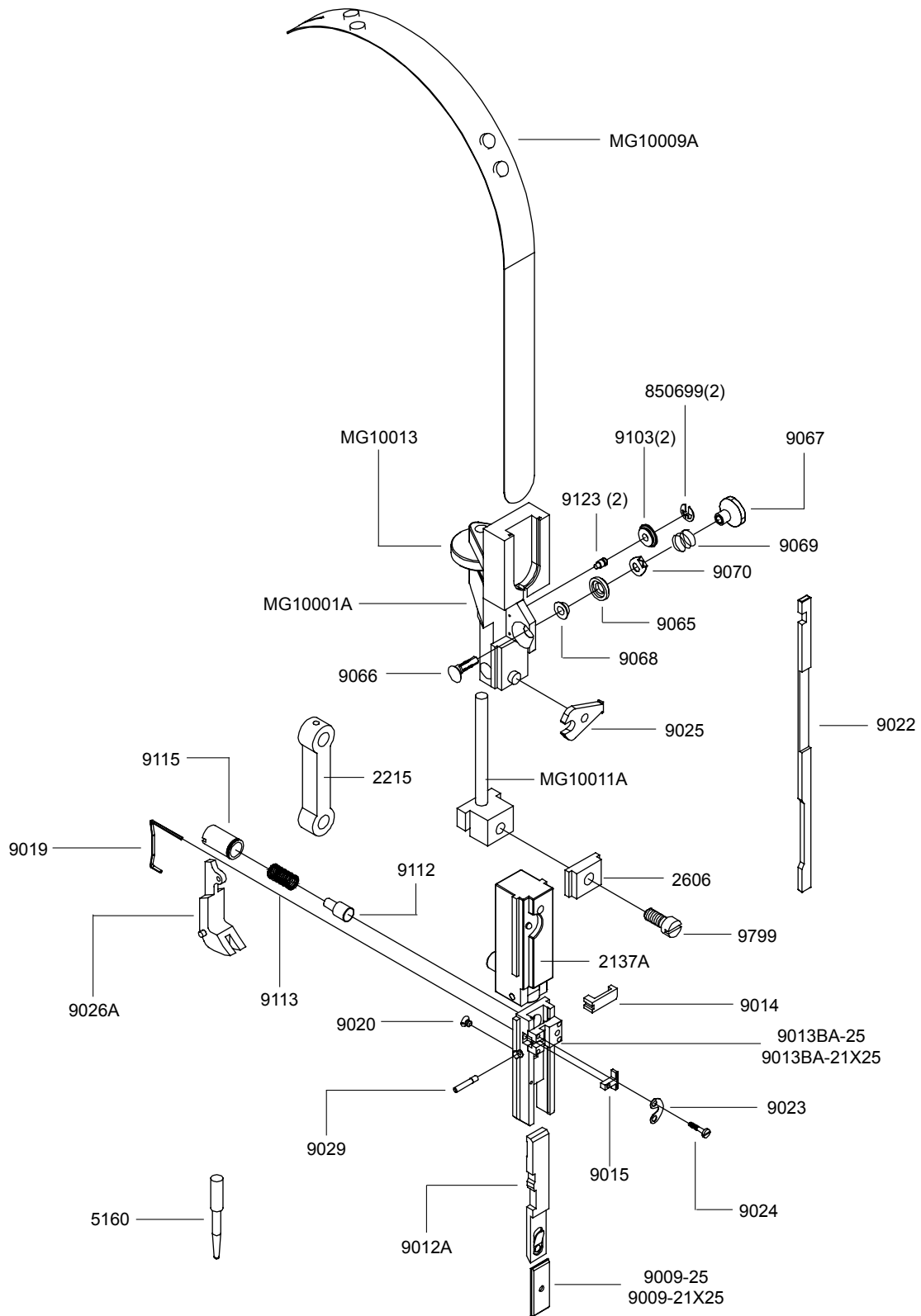

Internal Wiring Schematic

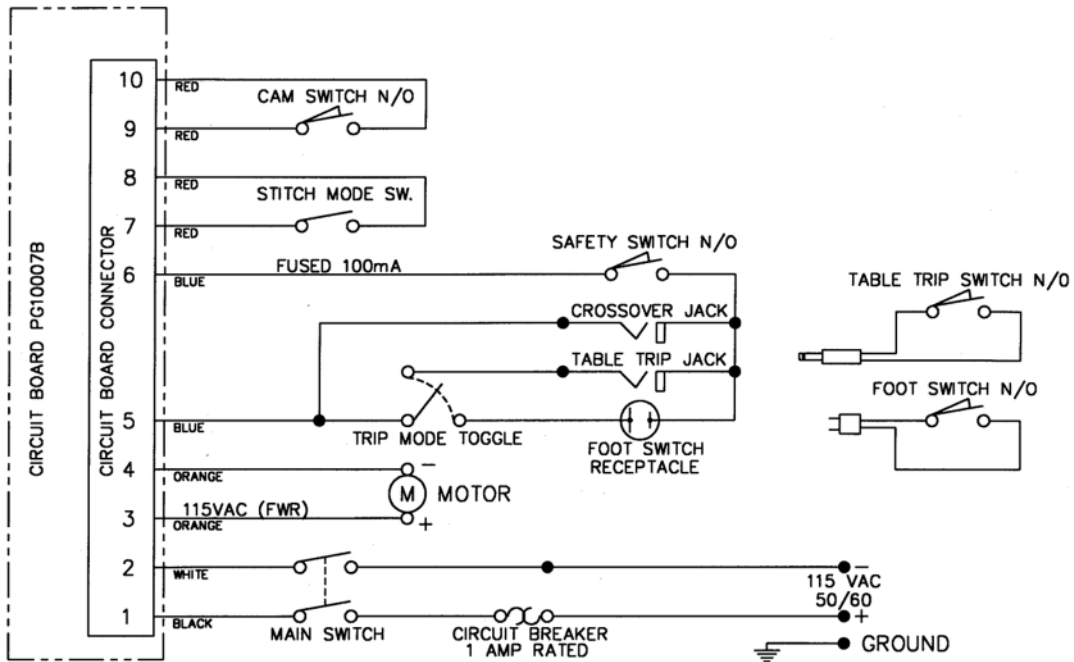

MODEL: SM-A

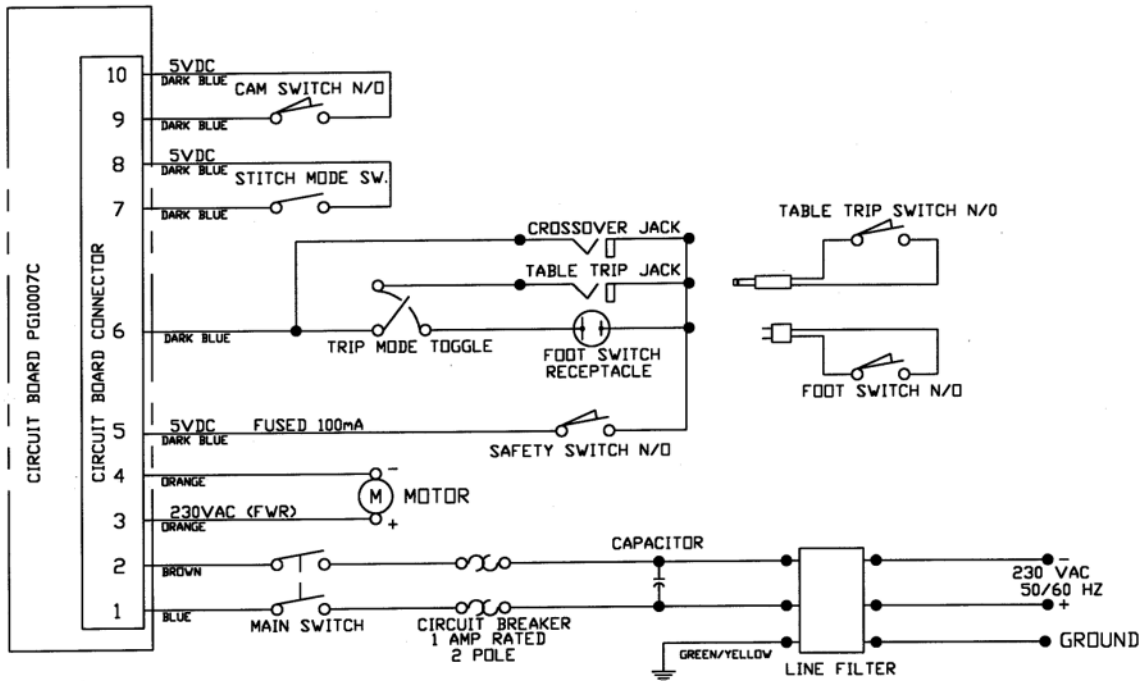

MODEL: SM-CE

Part Number / Description Cross-Reference

PART NO.	DESCRIPTION	QUANTITY	PART NO.	DESCRIPTION	QUANTITY
0084	Solid Face Plate Clip Screw	1	9030	Supporter Guide Plate	2
2001ASMHD251/2	StitchMaster Head	1	9032	Supporter Spring	1
2001ASMHD21251/2	StitchMaster Head	1	9033	Roll Pin	1
2103B	Driving Slide Pin	1	9034	Supporter Spring Lever Screw	1
2110B	Wire Guide Spring Stud	4	9035	Supporter Spring Lever Roll	1
2125G5	5lb Wire Spool - Flat	1	9036A	Supporter Spring Lever Assembly	1
2132BA	Face Plate	1	9037	Supporter Spring Lever Bushing	1
2137A	Driving Slide Assembly Link	1	9038M	Swivel Assembly - Magnetic	1
2144	Driving Slide Spring Plunger	1	9042	Swivel Safety Pin	1
2157	Supporter Lever Lock Shoe	1	9043B	Swivel Holder	1
2159	Supporter Spring Screw Washer	1	9044B	Swivel Holder Screw	1
2214	Driving Slide Crank Pin	1	9046A	Swivel Operating Spring	1
2215	Driving Shaft Connection Link	1	9047	Swivel Operating Spring Pin	1
2228	Driving Slide Pin Washer	2	9048	Wire Cutter	2
257	Block Rivet	3	9049	Wire Cutter Operating Slide	1
25G5	5 lb Wire Spool - Round	1	9050	Wire Cutter Oper. Slide Friction Plug	1
2601R	Bonnet	1	9051	Wire Cutter Oper. Slide Friction Spring	1
2606	Face Plate Lock Clamp	1	9052	Wire Cutter Operating Slide Stop Pin	1
2626	Driving Slide Spring	1	9056	Face Plate Retaining Clip	3
5037	Retaining Clip Rivet	1	9058	Swivel Operating Lever Screw	1
5160	Driver Release Pin	1	9059	Swivel Operating Lever Stud	1
85018	Wire Straightener Roll Clip	2	9064	Tension Pawl Stud	1
850699	Wire Straightener Roll Clip	2	9065	Wire Straightener Eccentric Roll	2
85199	Ring Terminal	1	9066	Wire Straightener Eccentric	2
9002	Bonnet Clamp Block	1	9067	Wire Straightener Eccentric Nut	2
9003A	Bonnet Clamp Handle	1	9068	Wire Straightener Eccentric Bushing	2
9006	Driving Slide Spring	1	9069	Wire Straightener Eccentric Spring	2
9009-25	Driver - 1/2"	1	9070	Wire Straightener Eccentric Pointer	2
9009-21x25	Driver - 1/2"	1	9075	Wire Guide Spring Bracket Screw	1
9010	Retaining Clip	1	9079	Supporter Guide Plate Dowel	2
9012A	Driver Bar Assembly - 1/2"	1	9081	Screw	2
9013BA-25	Bender Bar - 1/2"	1	9082	Driving Slide Spring Lock Pin	1
9013BA-2125	Bender Bar - 1/2"	1	9083A	Clincher Point	2
9014	Latch	1	9083C	Clincher Point - Thick, Flat	2
9015	Grip	1	9097	Grip Release Lever Pin	1
9017	Bender Bar Carriage	1	9098	Tension Pawl	1
9019	Grip Spring	1	9103	Wire Straightener Roller	5
9020	Grip Spring Retaining Screw	1	9112	Bender Bar Friction Plug	1
9022	Grip Release Slide	1	9113	Bender Bar Friction Spring	1
9023	Grip Retaining Clip	1	9115	Bender Bar Friction Bushing	1
9024	Grip Retaining Clip Screw	1	9123	Wire Straightener Roll Stud	5
9025	Release Slide Lever	1	9124	Wire Straightener Roll Clip	4
9026A	Supporter Assembly	1	9127	Swivel Operating Lever Stud	1
9029	Supporter Pivot Pin	1	9129B	Swivel Operation Spring Stud	1

Part Number / Description Cross-Reference

PART NO.	DESCRIPTION	QUANTITY	PART NO.	DESCRIPTION	QUANTITY
9130	Tension Pawl Rivet	1	MG10040	Shaft Extension Tube	1
9132B	Rivet	2	MG10041	Shaft Extension	1
9133	Rivet	1	MG10044B	Cover	1
9134	Tension Pawl Spring	1	MG10049A	Trip Switch Plug Assembly	1
9139	Swivel Operating Stop Pin	2	MG10051A	Clincher Arm Assembly	1
9140	Swivel Operating Spring Pin Washer	1	MG10052A	Clincher Arm	1
9144C	Wire Cutter Holder	1	MG10060	Clincher Slide Strap	1
9163	Swivel Operating Hub	1	MG10061	Clincher Lever	1
9164B	Driving Slide Swivel Operating Pin	1	MG10062	Clincher Slide	1
9166	Wire Cutter Locating Pin	1	MG10063	Clincher Plate Mounting Block	1
9171	Solid Face Plate Clip	1	MG10064	Clincher Lever Pivot Pin	1
9799	Face Plate Locating Screw	1	MG10067	Cam Lever	1
9800A	Clincher Plate - Movable	1	MG10068	Cam Roller	1
FSK1	Floor Stand	1 (optional)	MG10069	Cam Lever Spacer	1
G30173	Self Tap Screw 8x3/8	2	MG10070	Clincher Rod	1
HN1032	Nut 10-32	1	MG10071	Clincher Rod Sleeve	1
HN1213	Bonnet Stud Nut	1	MG10072	Clincher Rod Stud	1
HN1420	Nut 1/4 - 20	1	MG10075	Clincher Arm Cover	2
HN440.3	Nylon Insert Lock Nut	1	MG10076	Clincher Arm Clamp Rod	1
HN440.4	Hex Nut	1	MG10077	Clincher Arm Clamp Pad	1
HN1420	Nut 1/4 - 20	1	MG10081	Left Side Stop Rod	1
LW8	Lock Washer	1	MG10082	Right Side Stop Rod	1
LW14	Lock Washer 1/4"	6	MG10083	Front Work Table	1
MG10001A	Wire Guide Spring Bracket Assembly	1	MG10083A	Front Work Table Assembly	1
MG10006BA	C.E. Motor Assembly	1	MG10084	Left Pivot Plate	1
MG10009A	Wire Guide Spring Assembly	1	MG10085	Right Pivot Plate	1
MG10011A	Face Plate Adjustment Slide Assembly	1	MG10086	Switch Pin Sleeve	2
MG10012	Face Plate Adjustment Rod	1	MG10087	Side Stop Rod Guide	1
MG10013	Face Plate Adjustment Nut	1	MG10091	Rear Work Table	1
MG10014B	Wiring Assembly (110V)	1	MG10091A	Rear Work Table Assembly	1
MG10014C	Wiring Assembly - CE (220V)	1	MG10092	Rear Work Table Spring	2
MG10021B	Base Plate	1	MG10093	Spring Backing Plate	2
MG10022B	Side Panel	1	MG10094	Rear Table Pivot Block	2
MG10023	Main Switch Panel	1	MG10097	Front Table Adjustment Handle	1
MG10024	Safety Switch Panel	1	MG10098	Work Table Adjustment Nut	1
MG10026	Head Mounting Plate	1	MG10100	Trip Lever	1
MG10027	Cam Switch Mounting Plate	1	MG10101A	Trip Switch Plate Assembly	1
MG10028A	Circuit Board Platform	1	MG10104	Trip Lever Pivot Pin	1
MG10030	Clincher Cam	1	MG10105	Lock Nut	1
MG10031A	Crank Assembly	1	MG10106A	Trip Switch Assembly	1
MG10032	Control Cam	1	MG10107	Trip Switch Cover	1
MG10034	Safety Trip	1	MG10110	Spool Shaft	1
MG10035A	Guard Arm Assembly	2	MG10112	Wire Spool Washer	2
MG10037	Guard Spring Rod	1	MG10113	Wire Spool Cradle	1

Part Number / Description Cross-Reference

PART NO.	DESCRIPTION	QUANTITY	PART NO.	DESCRIPTION	QUANTITY
MG10200A	C.E. Power Kit	1	PG10259	10 Pin Connector	1
MG10202A	Receptacle Kit	1	PG10261	Square Key 1/8 x 1/2	2
P2126	Lock Nut Washer 1/4	1	PG10262	Clincher Lever Spring	1
P2152	Washer 1/2"	1	PG10268	On/Off Switch - 220V	1
P2930	Nut 8-32	1	PG10270	Retaining Ring	1
P3793	Clincher Arm Clamp Knob	1	PG10271	Washer 9/16	1
P5106	Screw 6-32x3/8	2	PG10289	Brush Assembly	1
P6477	Clincher Lever Spring Pin	1	PG10290	Brush Holder	1
P6794	Screw 10-24 x 5/8	4	PG10291	Screw 10 - 24 x 1/4	1
P7651	Nut 6-32	4	PG10292	Terminal 1/16x90	8
PG10003	Head Guard	1	PG10293	1/8 Hex Nut Wrench	1
PG10006	Gear Motor 115V	1	PG10326	Screw, 8 - 32 x 1/8	2
PG10006B	Gear Motor -CE 220V	1	PG10406	2 Pole Circuit Breaker	1
PG10007B	Circuit Board (110V)	1	PG10407	Shoulder Washer 1/4	2
PG10007C	Circuit Board - CE (220V)	1	PG10410	Power Cord and Plug	1
PG10017	Face Plate Adjustment Rod Pin	1	PG10411	RFI Filter	1
PG10202	Tension Spring	1	PW10	Washer #10	1
PG10203	Screw 4-40x1/2	3	PW10.3	Washer 3/16	6
PG10205	Spirol Pin 1/8x3/4	2	SMK3	Double Head Conversion Kit	1 (optional)
PG10206	Nylon Bushing 9/16	1	SMK4	Double Head Mounting Plate	1 (optional)
PG10207	Screw 8-32x1/2	1	SMK6	Circuit Board Kit	1 (optional)
PG10208	Shaft Extension Spring	1	SW10	Lockwasher	1
PG10209B	Vibration Pad	2	UA1304.1	Safety Trip Screw	2
PG10211	Shaft Extension Handle	1	UA2305.2	Face Plate Retaining Clip Screw	3
PG10216	Circuit Board Spacer	4	UA2406.1	Screw 8 - 32 x 3/8	3
PG10219	Terminal 1/4x90	4	UA3803	Screw 10 - 32 x 3/16	1
PG10220	Straight Terminal 3/16	10	UA3804.7	Screw 10-32x1/4	9
PG10226	2 Prong Receptacle	1	UA3806.1	Supporter Lever Lock Screw	1
PG10227	Phone Jack 141	2	UA3806.3	Screw 10 - 32 3/8	3
PG10228B	On/Off Switch	1	UA3808.1	Screw 10 - 32 1/2	2
PG10229	Snap Switch	3	UA3812.2	Screw 10 -32 x 3/4	2
PG10230	Foot Switch w/ Guard	1	UA3812.4	Supporter Lever Stop Screw	1
PG10232	Trip Mode Switch	2	UA4110.1	Screw 1/4 - 20x5/8	4
PG10233	Adhesive Wire Clamp	5	UA4808.3	Screw 1/4 - 20 x 1/2	2
PG10238	Cam Roller Screw	2	UA4812.7	Screw 1/4 - 20 x 3/4	6
PG10242	Self Lock Pin 3/16x1	2	UB2111.2	Supporter Guide Pin	1
PG10243	Stop Rod Screw	2			
PG10246	Front Table Pivot Pin	1			
PG10247	Clevis Pin 1/4x1-1/2	1			
PG10248	Table Pivot Pin Clip	2			
PG10249	Front Table Adjustment Spring	1			
PG10251	Spool Friction Spring	1			
PG10252	Spool Clip	1			
PG10257	Cam Switch Screw	2			

Optional Equipment

In addition to the standard features offered with the StitchMaster, optional equipment items can be purchased to better accommodate your stitching needs. The following kits can be purchased from your Graphic Arts Representative.

FSK1

This heavy duty Floor Stand allows you to place your StitchMaster wherever it is needed and adjusts from 28" to 42", securely mounting your StitchMaster. The Floor Stand Kit comes complete with easy to follow instructions and all the parts needed for assembly.

Place the Base Weldment (MG10131A) on the floor with the three screw holes up. Use the Leveling Screw (P6110) on the bottom right leg to level the Base. Attach the Post Weldment (MG10132A) using the three Screws (P9132) and Lock Washers (LW12.2) provided. Place the Slide Weldment (MG10133A) over the Post and lock it into the desired position using the Clamp Handle (MG10155). To finish, attach the four (4) Plugs (PG10267) to the bottom of the Base.

To avoid risk of personal injury never loosen clamp handle unless load on stand is supported. **WARNING**

SMK2 (Figure 21)

The SMK2 Backstop Kit is for use with the flat work table of your stitcher. The kit components can be assembled in various ways to fit specific applications. Choose the diagram which best fits your current needs and follow the instructions listed below.

Attach the Back Stop Clamp Blocks (MG10125) to the slots in your table by inserting the Carriage Bolts (PG10244) up through the slots in your work table and through the holes in the Clamp Block. Place the Lock Nuts (MG10105) on the ends of the Carriage Bolts. Slide the Back Stop Rod (MG10123) through the Clamp Blocks and Backstop Blocks (MG10124) as desired. Use the Nylon Stop Rod Screws (PG10243) to hold the Rod and Blocks in place.

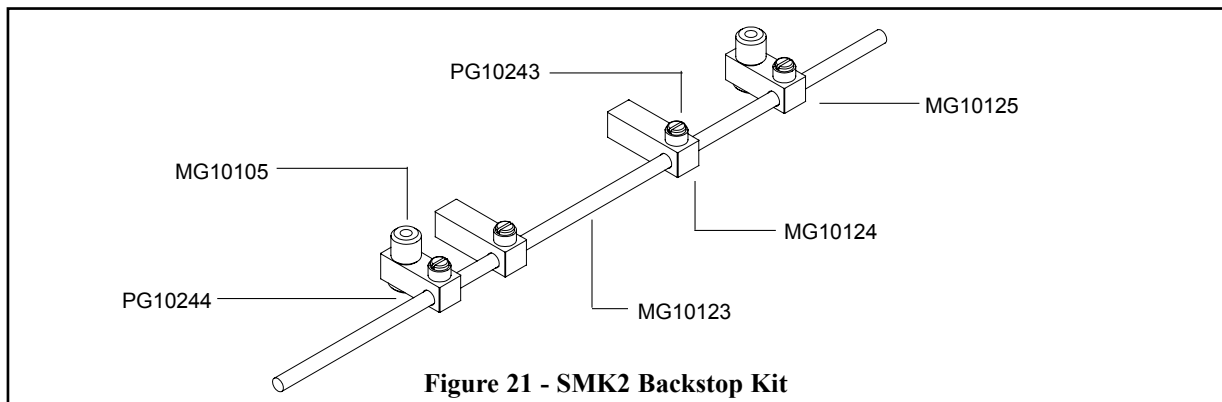

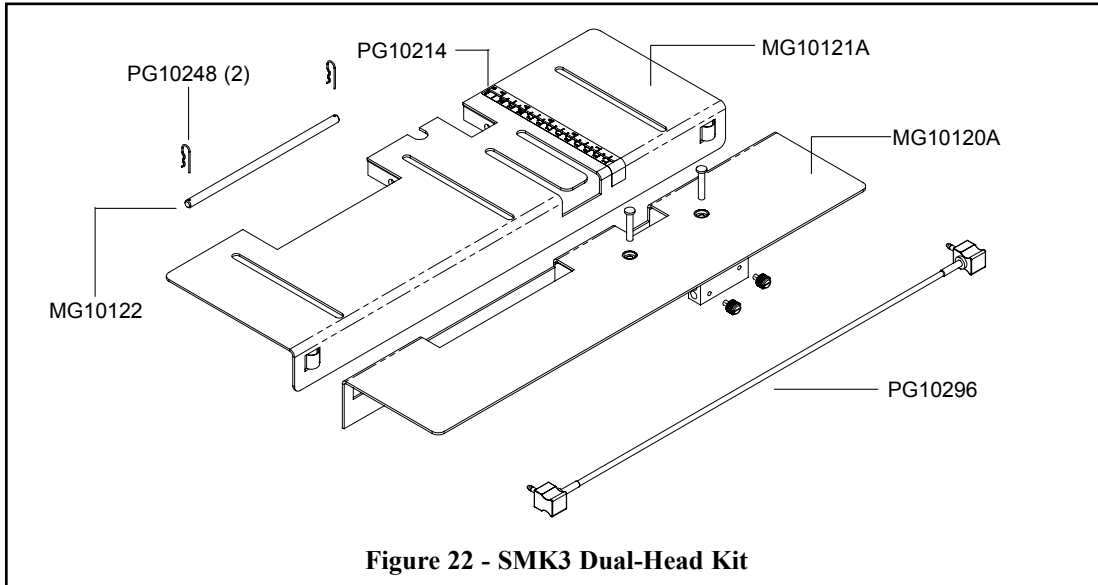

SMK3 (Figure 22)

The SMK3 Dual-Head Kit is for use with two StitchMasters mounted side-by-side on a work table or on an FSK1 Adjustable Floor Stand with a SMK4 Double Head Mounting Plate Assembly Kit, both sold separately. Install the Dual-Head Kit by following the steps listed below.

Mount the two StitchMasters side-by-side (4"-8" center-to-center) with the standard tables removed and the power off. Slip the Front Work Table (MG10120A) over both Clincher Plate Mounting Blocks (MG10063) and lock the right Clamp Handle (MG10155) in place. Install the Table Pivot Rod (MG10122) in the pivot hole and lock it into place with the Table Pivot Pin Clip (PG10248). Remove these parts from one of your standard tables. Place the the other Table Pivot Rod through the left-most Pivot Plate, the left Clincher Plate Mounting Block and the second Pivot Plate as shown. Lock into place with the Clips.

Install the Rear Work Table (MG10121A) using the same Pins and Clips as on the Front Work Table. The machines must be parallel to each other so the tables do not cause binding. It may be necessary to loosen the clamp on one of the two machines to align them properly. Install the Side Stop Rods, Locking Screws and Corner Stitching Pins. Install the Table Trip Assembly and plug it into the bot-

Be sure that both StitchMasters are off before you plug in or unplug the Connector Cord. If not, one or both machines may cycle unexpectedly.

⚠ WARNING

tom of the machine on the right. Plug the ends of the Cordset Phone Plug (PG10296) into the back receptacles on each machine marked “crossover.” Install the Foot Switch into the receptacle on the right machine.

Turn both machines on. Use either the Foot Switch or the Table Trip Switch to operate both StitchMasters. Make sure the Trip Mode Switch on the machine on the right is set for the switch you plan to use (Foot or Table). Set both Stitch Mode Switches to single stitch mode.

Note: In order to use only one StitchMaster, simply turn the machine you choose not to use off and use the other machine as you would a single machine.

SMK4 (Figure 23)

The SMK4 Dual-Head Mounting Plate Assembly Kit is for use with an FSK1 Adjustable Floor Stand and two StitchMasters mounted side-by-side. To mount the Assembly, follow the instructions below.

Remove the StitchMaster from the Floor Stand, if it is already mounted. Remove the four (4) Screws (P2089) from the SMK4 Double Head Mounting Plate (MG10147). Place the Mounting Plate on top of the Stand and align the screw holes. The front of the Mounting Plate should be flush with the front of the Stand. Place the four screws through the holes, from the bottom and tighten with a wrench. Mount your StitchMasters on the Mounting Plate, side-by-side.

CAUTION
Do not tighten the Clamp on an uneven surface.

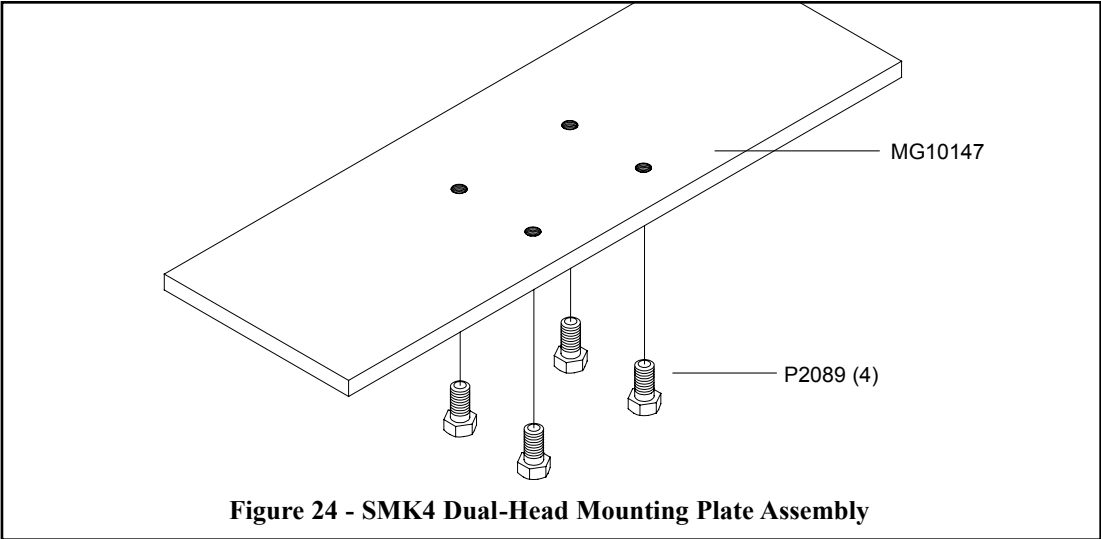

Figure 24 - SMK4 Dual-Head Mounting Plate Assembly

REGISTRATION

To better service your wire stitching needs, please take a moment to fill out and return this registration card.

CUSTOMER

Name : _____
(First) (Middle Initial) (Last)
Company : _____
Street Address : _____
City : _____ State/Province : _____ Zip : _____
Country : _____
Phone : _____ Fax : _____ E-mail : _____

PRODUCT

Machine(s) Purchased : _____
Serial Number(s) : _____
With Head(s) : _____
(Type/Quantity Purchased)
Serial Number(s) : _____
Head(s) Purchased : _____
Serial Number(s) : _____

DEALER

Date Received : _____
Dealer Name : _____
Dealer Street Address : _____
City : _____ State/Province : _____ Zip : _____
Country : _____
Dealer Phone : _____

Other Bindery Products Used : _____

Please take a moment to fill out the attached card and mail it to DeLuxe Stitcher Company, Inc..
In addition, duplicate the information for your records to assist when making further inquiries.

PRODUCT

Machine(s) Purchased : _____
Serial Number(s) : _____
With Head(s) : _____
(Type/Quantity Purchased)
Serial Number(s) : _____
Head(s) Purchased : _____
Serial Number(s) : _____

DELUXE STITCHER GRAPHIC ARTS REPRESENTATIVE

Date Received : _____
Dealer Name : _____
Dealer Street Address : _____
City : _____ State/Province : _____ Zip : _____
Country : _____
Dealer Phone : _____

Would you like information sent to you about new products that would benefit your company? Yes No

Common Replacement Parts

Below is a list of the most common wear/replacement parts for the StitchMaster. This guide should help you when ordering replacement parts. If the part you need is not listed below, please refer to the more detailed parts list on pages 46-48 in this manual.

Description	Item Number
Clincher Points	9083A
Driver	9009-25
Grip	9015
Grip Retaining Clip	9023
Grip Retaining Screw	9024
Bender Bar Latch	9014
Grip Spring	9019
Grip Spring Retaining Screw	9020
Swivel Operating Spring	9046A
Swivel	9038M
Wire Cutter	9048
Motor Brush Assembly	PG10289
Driver Bar	9012A
Clincher Plate	9800A
Supporter -1/2"	9026A

**PLACE
STAMP
HERE**

**DELUXE STITCHER
COMPANY, INC.**
6635 West Irving Park Road
Chicago, Illinois 60634-2410 U.S.A.
Attn: Customer Service

LIMITED WARRANTY

DeLuxe Stitcher Company, Inc. warrants to the original retail purchaser that this product is free from defects in material and workmanship and agrees to repair or replace, at DeLuxe Stitcher's option, any defective product within 90 days from the date of purchase. This warranty is not transferable. It covers damage resulting only from defects in material or workmanship and does not cover conditions or malfunctions resulting from normal wear, neglect, abuse or accident.

This warranty is in lieu of all other express warranties. Any warranty of merchantability or fitness for a particular purpose is limited to the duration of this warranty. DeLuxe Stitcher shall not be liable for any incidental or consequential damages.

Some states do not allow limitations on how long an implied warranty lasts, or the exclusion or limitation of incidental or consequential damages, so the above limitations or exclusions may not apply to you. This warranty gives you specific legal rights and you may also have other rights which vary from state to state.

To obtain warranty service you must return the product, at your expense, together with proof of purchase to an authorized DeLuxe Stitcher Company Graphic Arts Dealer.

Always use genuine DeLuxe Stitcher parts. When ordering parts, please identify the part number, the part name, the wire size and crown size of your Stitcher.

DeLuxe Stitcher Company, Inc.
Chicago, Illinois 60634-2410
Phone: 773-777-6500 800-634-0810
Fax: 773-777-0156 800-417-9251
E-mail: info@deluxestitcher.com
Web Site: <http://www.deluxestitcher.com>



Declaration of Conformity

We, *DeLuxe Stitcher Company, Inc.*

6635 West Irving Park Road
Chicago, Illinois 60634-2410 U.S.A
Telephone 773-777-6500
Facsimile 773-777-0156

hereby declare under our sole responsibility that the

SM-CE *Stitching/Stapling Machines*

to which this declaration relates is in conformity with the
following European product safety directives:

Machinery Safety Directive

(89/392/EEC and amendments
91/368/EEC, 93/44/EEC, 93/68/EEC)

Electromagnetic Compatibility Directive

(89/336/EEC and amendments
91/C162/08, 92/31/EEC, 93/68/EEC)

as is verified by compliance with the following standards:

EN 60204-1:1992	prEN 894-1:1992	prEN 953:1992
EN 294:1992	prEN 894-3:1992	EN 55014:1193
prEN 614-1:1991	prEN 1050:1993	EN 55104:1995

Executed for *DeLuxe Stitcher Company, Inc.*

this first day of January in the year 2007

By Frank P. Cangelosi Signature Frank P. Cangelosi

Title President



